



# **Vault Series**

**Ruggedized, True On Line,  
Double Conversion  
Uninterruptible Power Supply**

**USER MANUAL FOR MODELS:  
700VA - 1500VA**



# Table of Contents

<b>Safety Instructions.....</b>	<b>1</b>
<b>1. Introduction.....</b>	<b>3</b>
<b>2. System Description.....</b>	<b>3</b>
2.1 General Description.....	3
2.2 System Configuration and Sizing.....	4
<b>3. Safety Information.....</b>	<b>5</b>
<b>4. Storage.....</b>	<b>5</b>
<b>5. Installation.....</b>	<b>6</b>
5.1 Environment.....	6
5.2 AC Power and Load Connections.....	6
5.3 Dry Contact Relay Connections.....	7
UPS Wiring Diagram w/o PTS.....	8
UPS Wiring Diagram w/ PTS.....	9
120V Front View and Connections.....	10
120V Nema Rear View and Connections.....	11
220V IEC Rear View and Connections.....	11
<b>6. Operational Instructions.....</b>	<b>12</b>
6.1 Starting Up and Shutting Down the UPS.....	12
6.2 Push Button Operation.....	12
6.3 Control Panel Indicators.....	13
6.4 LCD Panel Display Modes.....	14
6.5 Manual UPS or Battery Test.....	15
6.6 Audible Alarms.....	16
6.7 Time Delay Relay Controller.....	16
6.8 Maintenance Bypass Procedure.....	17
<b>7. Batteries and Maintenance.....</b>	<b>18</b>
7.1 Protective Equipment.....	19
7.2 Receiving and Storage.....	19
7.3 Installation.....	20
7.4 Battery Assembly.....	20
7.5 Record Keeping.....	21
7.6 Maintenance.....	22
7.7 Troubleshooting.....	24
<b>8. Maintenance.....</b>	<b>25</b>
8.1 Battery Replacement.....	25
8.2 Storage Requirements.....	25
<b>9. Specifications.....</b>	<b>26</b>
Rack Mount Model Specifications.....	26
Tower Model Specifications.....	27
Dimensions: 700TR / 1000TR / 1500TR.....	28
Dimensions: 700RTR / 1000RTR / 1500RTR.....	29
<b>Warranty.....</b>	<b>30</b>



# IMPORTANT SAFETY INSTRUCTIONS SAVE THESE INSTRUCTIONS



1. This Manual Contains Important Instructions that should be followed during Installation and Maintenance of the UPS and Batteries.
2. The equipment can be operated by any individual. No previous experience is required.
3. **CAUTION (UPS with Internal Batteries):** Risk of electric shock - Hazardous live parts inside this unit are energized from the battery supply even when the input AC power is disconnected.
4. **CAUTION (No User Serviceable Parts):** Risk of electric shock, do not remove cover. No user serviceable parts inside. Refer servicing to qualified service personnel.
5. **CAUTION (Non-isolated Battery Supply):** Risk of electric shock, battery circuit is not isolated from AC input / output; hazardous voltage may exist between battery terminals and ground. Test before touching.
6. **WARNING (Fuses):** To reduce the risk of fire, replace only with the same type and rating of fuse.
7. **WARNING:** Intended for installation in a controlled environment. The maximum ambient temperature is 60°C.
8. **CAUTION:** When replacing batteries, replace with the same type and number of batteries: Only use sealed lead acid battery.
9. **CAUTION:** Do not dispose of batteries in a fire, as they may explode.
10. **CAUTION:** Do not open or damage the battery, electrolyte may be released which is harmful to the skin and eyes.
11. **CAUTION:** A battery can present a risk of electric shock and high short circuit current. The following precautions should be taken when working with batteries:
  - a. Remove watches, rings and other jewelry or metal objects.
  - b. Use only tools with insulated handles.
  - c. Wear rubber gloves and boots.
  - d. Do not lay tools or metal parts on top of batteries.
  - e. Disconnect charging source prior to connecting or disconnecting battery terminals.
12. To reduce the risk of electric shock, disconnect the UPS from the AC input power supply before installing a communication interface cable. Reconnect the power cord only after communication interconnections have been made.
13. Battery replacement should be performed or supervised by personnel with knowledge of batteries. Keep unauthorized personnel away from the batteries.
14. **CAUTION:** To reduce risk of fire, use only No. 26 AWG or larger telecommunication line cord.
15. **CAUTION:** To reduce risk of fire, connect only to a circuit provided with branch circuit over-current protection in accordance with the National Electric Code, ANSI/NFPA 70". An AC output disconnect shall be provided by others.

The instructions contained within this safety manual are extremely important and should be closely followed at all times during installation and follow-up maintenance of the UPS and battery.



## CAUTION

**The unit contains dangerous voltage levels. If the UPS is on, but not connected to an AC power supply, the unit's outlets may still be energized with voltage due to the presence of an additional power source, ie. the battery.**

**The unit should be installed indoors in an area free of electrically-conductive contaminants.**

**The unit should be installed in a temperature and humidity controlled environment in order to reduce the risk of electric shock and failure.**

**Only the power cord that is supplied with the unit should be used to connect it to the AC power supply. The equipment should also be located as close as possible to the AC supply.**

**Servicing and maintenance should only be carried out by qualified service personnel with the exception of battery replacement.**

**Before carrying out battery or fuse replacement or shipping the unit, first ensure that the unit is turned off completely and all cables are disconnected.**

For additional safety instructions, please use the Safety Manual as reference.

## Symbols

The following symbols warn of precautions and provide directions or instruction regarding the unit:



**RISK OF ELECTRIC SHOCK** – Indicates that there is a risk of electric shock.



**CAUTION: REFER TO OPERATOR'S MANUAL** – Indicates that the operator's manual should be referred to for additional information, such as operating and maintenance instructions.



**SAFE GROUNDING TERMINAL** - Indicates primary safe ground.



**LOAD ON/OFF** – Indicates that the associated push-button turns the unit and its output on or off.



**RJ-45 CONNECTOR** – Indicates that this connector provides network interface connections and that telephone or telecommunications equipment should NOT be plugged into it.



**DISPOSAL** – Indicates that the UPS and its batteries should be disposed of in the correct manner since the batteries are of the lead-acid type. It is recommended that the batteries be recycled.

# 1. Introduction

The information provided in this manual refers to our ruggedized single phase, 700VA through 1500VA, true on-line uninterruptible power supplies. It covers basic functions, operating and installation instructions, cautionary notes and detail on how to ship, store and handle them. Installation must be carried out in accordance with this manual as well as local electrical regulations and should only be performed by qualified personnel to avoid the risk of electric shock or damage to the unit. Any warranties covering these units will become void if the unit is found to have been incorrectly connected or tampered with.

# 2. System Description

## 2.1 General description

Configured as a true, on-line double conversion unit, this UPS is able to supply seamless, pure single-phase AC power to critical loads while keeping the batteries charged continuously. In the event that a power interruption lasts longer than the UPS's backup time capability, it will shut down to avoid complete battery discharge. As soon as AC power is restored, the UPS will automatically restart and begin recharging the batteries.

A block diagram of the UPS infrastructure is shown in Fig. 1:

- An input filter reduces transients, noise and surges on the incoming AC supply
- AC power is rectified and regulated by the rectifier supplying power to the inverter and battery converter. Battery voltage and charge is maintained at optimum levels.
- DC power is converted to AC power by the inverter which passes it on to the load.
- Power is supplied from the battery during a power failure or deep voltage sag.
- The converter increases voltage to an appropriate level for the inverter.
- An integral automatic bypass switch seamlessly circumvents the electronics in the event of a component failure ensuring continuous power to the load.

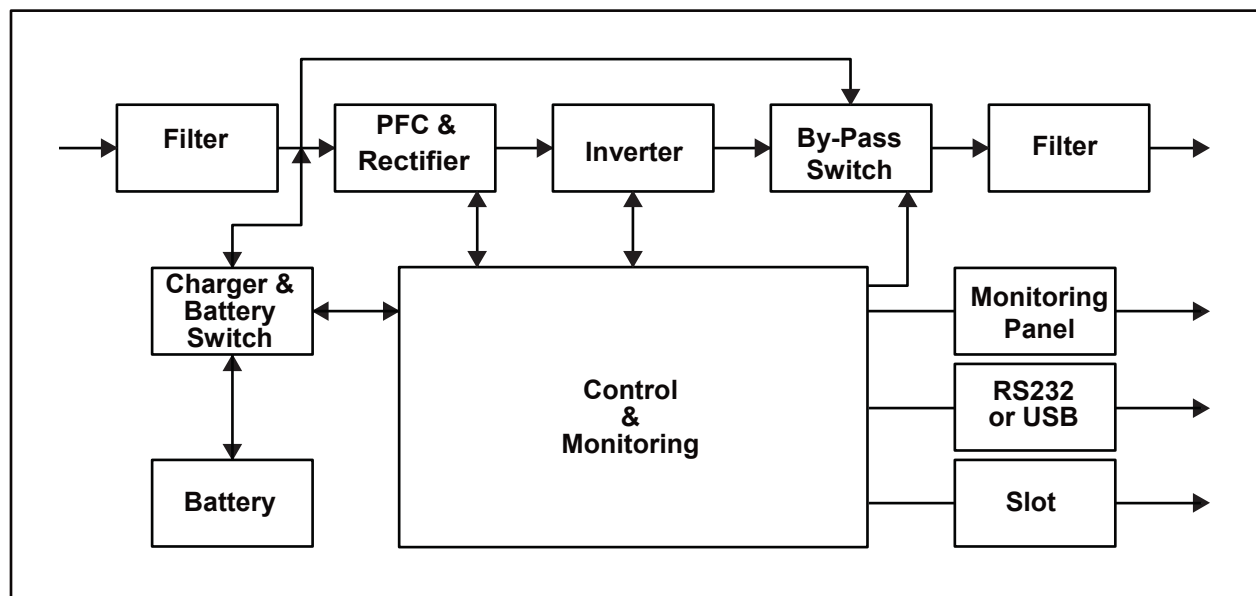

## Efficiency Optimizer

The Efficiency Optimizer is a unique feature that reduces long-term cost of ownership by minimizing power loss and reducing power consumption thereby making the entire system extremely efficient. Simply put, the UPS automatically alternates between bypass and on-line modes depending upon the condition of the incoming AC power. The UPS will remain in on-line mode during any type of power disturbance but unlike traditional on-line systems, will switch to bypass mode when AC power is within acceptable limits in order to achieve greatest efficiency. Power disturbances can be detected in less than a second, and on-line mode reactivated immediately. Switching back to online mode occurs when the input voltage is outside of  $\pm 10\%$  of nominal ( $\pm 15\%$  selectable), when input frequency is outside of  $\pm 3\text{Hz}$  or when no AC power is present.

While the default operation is on-line mode, bypass can be activated via the LCD panel. The Efficiency Optimizer can be de-activated and the unit can be run permanently in on-line mode if preferred.

## Free Run Mode

Free run mode is defined as being when the output frequency is fixed and not synchronized with the input frequency. When activated, the output frequency regulation is automatically set to either 50 or 60 Hz and is regulated to within  $\pm 0.25\text{Hz}$ . Please refer to Chapter 7 for instructions on how to activate bypass mode while the UPS is in free run mode.

## Diagnostic tests

Whenever the UPS is turned on, a diagnostic test to check the status of the internal electronics and battery is activated. Any errors or faults are displayed on the LCD panel.

An advanced battery management system continuously monitors the condition of the batteries and notifies the user in advance if replacement is needed.

In addition, a basic battery discharge test is performed every 30 days in normal mode operation, and any problems are displayed on the LCD.

Diagnostic tests can be performed manually from the LCD panel at any time, except during the first 24 hours after startup while the UPS is in charging mode (see Chapter 7).

## 2.2 System Configuration and Sizing

The internal electronics of the UPS or batteries constitute the system. Please make sure that the following factors have been taken into consideration:

1. The total demand of the protected load determines the UPS power (VA) requirements. Allow some margin or headroom for future expansion or power requirement calculation inaccuracies.
2. Aside from power (VA) requirements, backup time needs to be considered. If the power consumed by the load is less than the nominal power rating of the UPS, then the actual backup time will be longer.
3. The following options are available, depending on application and load requirements:
  - a. Maintenance bypass switches
  - b. Communication and control options (e.g. relay card, SNMP / WEB card)
  - c. Mounting Brackets

### 3. Safety Information

#### PLEASE READ THIS SECTION TO AVOID RISK OF SHOCK OR OTHER HAZARDOUS SITUATIONS.

1. Please handle the unit with extreme caution since the batteries contain large amounts of energy. Always store the unit in the orientation marked on the packaging.
2. Take extra care to avoid dropping the unit.
3. If flammable substances are present or if any gases or fumes are being emitted or if there is no ventilation in the place of storage or installation, a safety hazard exists and neither the unit or the extended battery packs should be operated in these environments.
4. The instructions in this manual detail how to install the UPS safely and correctly. Please read it thoroughly and keep this manual for future reference.



**WARNING! It is strongly advised that the UPS NOT be opened by anyone other than suitably qualified personnel. Dangerously high voltages are present within, regardless of whether the UPS is connected or not. In addition, the unit's output receptacles may contain live AC voltage even when not connected to the AC power supply since it contains an alternate energy source, (i.e. batteries).**

#### User Allowable Operations

The only UPS-related operations that the user is allowed to perform are:

1. Turning the unit on and off.
2. Operating the user interface (function push-buttons and LCD panel).
3. Connecting data interface cables
4. Changing the batteries

All such operations are to be performed exactly as instructed in this manual. Any deviation from these instructions may prove hazardous and even fatal or may cause damage to the unit.

### 4. Storage

Please adhere to the following storage instructions if the UPS is not to be installed shortly after delivery:

1. Store the unit as is in its original packing and shipping container.
2. The optimum storage temperature range is: 0°C to 40°C).
3. Ensure that the equipment is fully protected from wet areas and from moisture.
4. Ensure that the batteries are recharged every 6 months for at least 8 hours in order to maintain battery energy and maximize useable life.



## 5. Installation

### 5.1 Environment

**Ensure that all environmental requirements are met, otherwise the safety of installation personnel and users cannot be guaranteed. In addition, the unit may sustain damage or malfunction.**

**Please adhere to the following environmental instructions when locating the UPS and EBP's:**

1. Avoid temperature and humidity extremes. The optimum operating temperature range can be found in the specifications section of this manual.
2. Provide protection against moisture or avoid altogether if possible.
3. Ensure there is at least 4 inches (100mm) behind and 2 inches (50mm) on each side of the UPS for ventilation.
4. Ensure that the front of the UPS remains unobstructed for access to the control panel and LCD display.
5. External Battery Packs must be installed next to or under the UPS.

### 5.2 AC Power and Load Connections

#### Vertical and Wall-Mount Installation

Only qualified technicians should carry out installation of this equipment. The installation must further comply with all local legislation and regulations.

Follow all installation and safety instructions very carefully to avoid the existence of hazardous situation and damage to the UPS and/or loads.

**The high voltage and current contained within this equipment can injure or be fatal to personnel and can damage associated equipment.**

Various input (and sometimes output) cables are supplied with all models:

1. Ensure that the UPS is disconnected from the AC supply when connecting External Battery Packs.
2. Use the battery cable that is supplied with the External Battery Pack when connecting it to the UPS. Connect the second battery cabinet to the first and so forth, assuming more than one is to be used.
3. Take note of UPS parameters when adding external battery packs and adjust accordingly (see Ch. 7).
4. Connect the input cable to the UPS and connect the other end to a grounded AC power supply. The batteries will automatically begin to charge. Please note that while the UPS may be used immediately, maximum back-up time may not be available until the batteries have been charged for a minimum of 8 hours.
5. If the unit displays "Site Wiring Fault", have the wiring fault corrected or alternately, disable the related alarm on the UPS.
6. After initial charging is complete, connect the loads to the UPS (see Figs 2.3 & 4).
7. Do not connect any load that may overload the UPS such as equipment containing AC electric motors or loads that have a high inrush current.
8. Make computer and/or alarm interface connections according to Chapter 6 of this user manual and that provided with the interface option. These connections are made on the rear panel.
9. Installation is now complete..

### 5.3 Dry Contact Relay Connections

The AS-400 Relay Card converts UPS communication signals to potential-free, dry contacts for industrial control. It is designed for internal use with Marathon Power's Vault Series UPS. Dry contact signals and pin-out details for the DB9 Connector are as follows:

#### Dry Contacts Cable

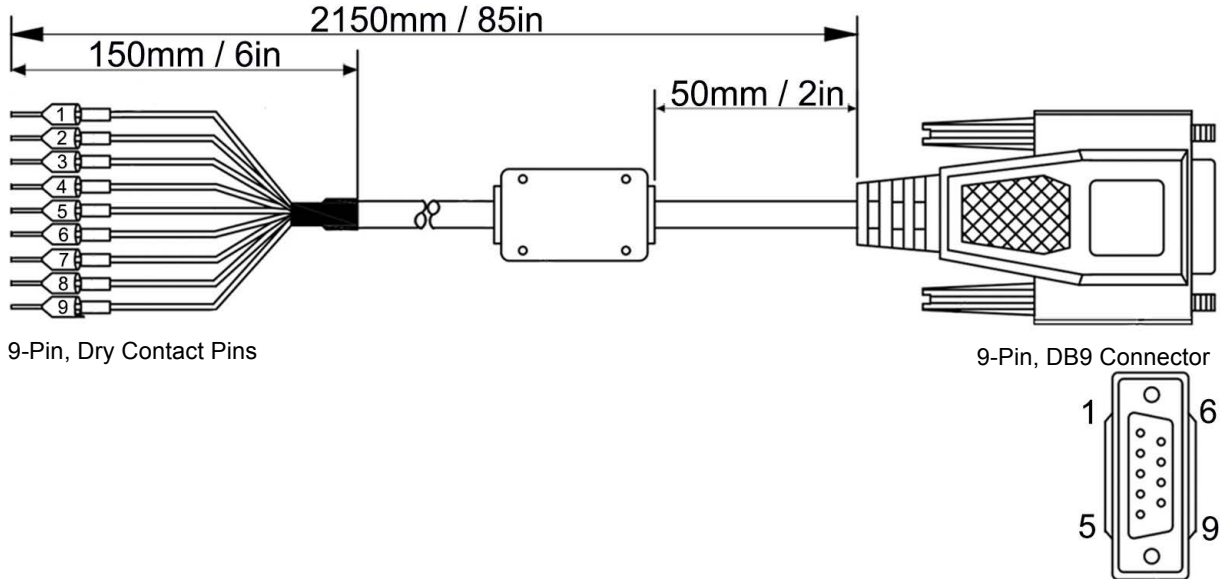

Pin #	Description	Input / Output
1	Description UPS fault, relay contact, normally open, active close.	Output
2	Summary alarm, relay contact, normally open, active close. One of the following conditions activate this signal: Battery test failure, Charger failure, Bypass active, Output fault, Bus fault, Inverter fault, Over-temp, Overload.	Output
3	GND for secondary	
4	Remote shutdown	Input
5	Common	
6	Bypass active, normally open, active close	Output
7	Battery low, normally open, active close	Output
8	Spare	
9	AC power failure, normally open, active close	Output

**Note:** The relays are by default Normally Open (Active Close) but the configuration can be changed to Normally Closed (Active Open) by jumper adjustment on the card.

**Note:** Contacts are rated at 1A, 24VDC or 1A, 120VAC.

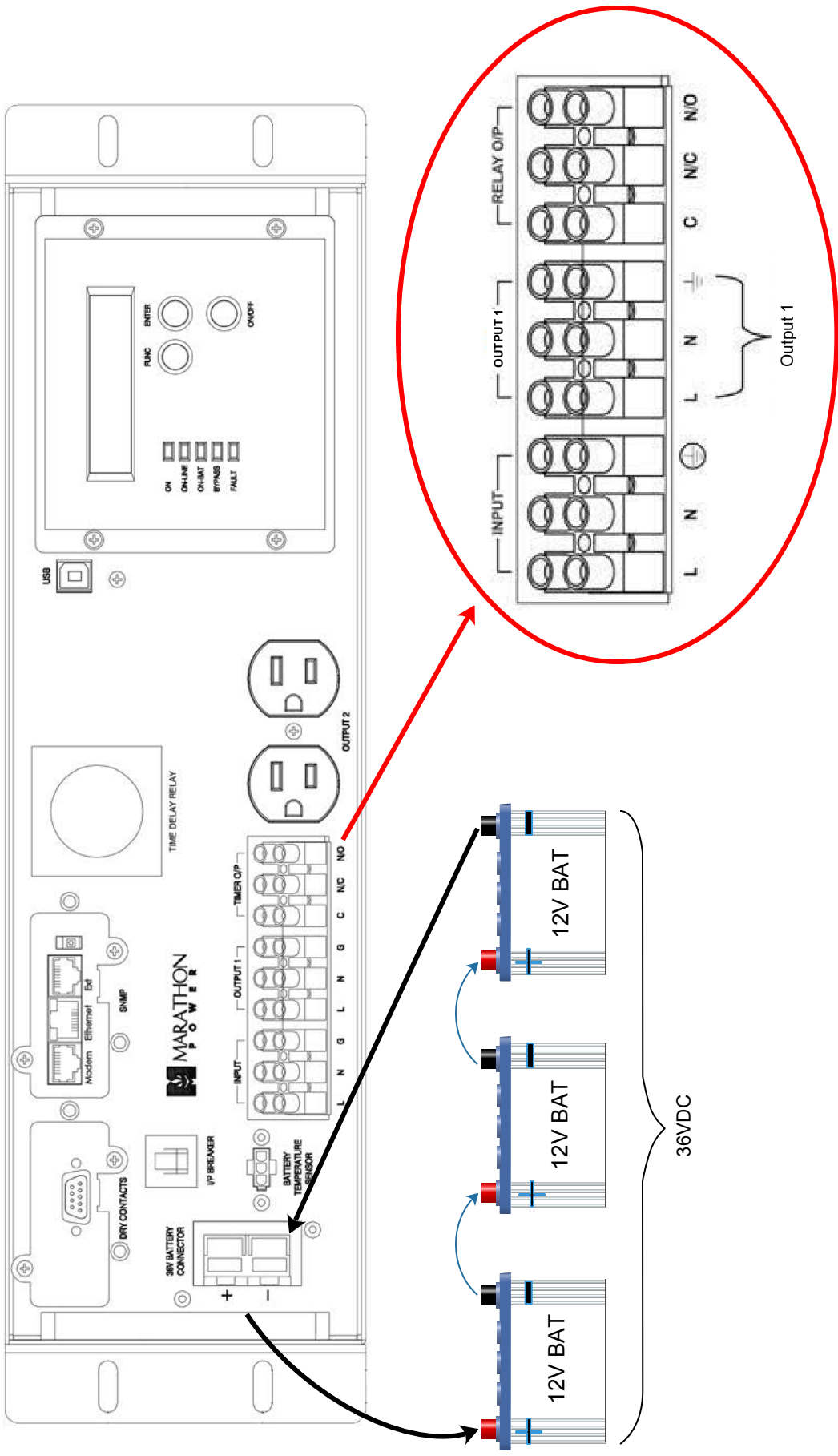

UPS Wiring Diagram without Power Transfer Switch (PTS)

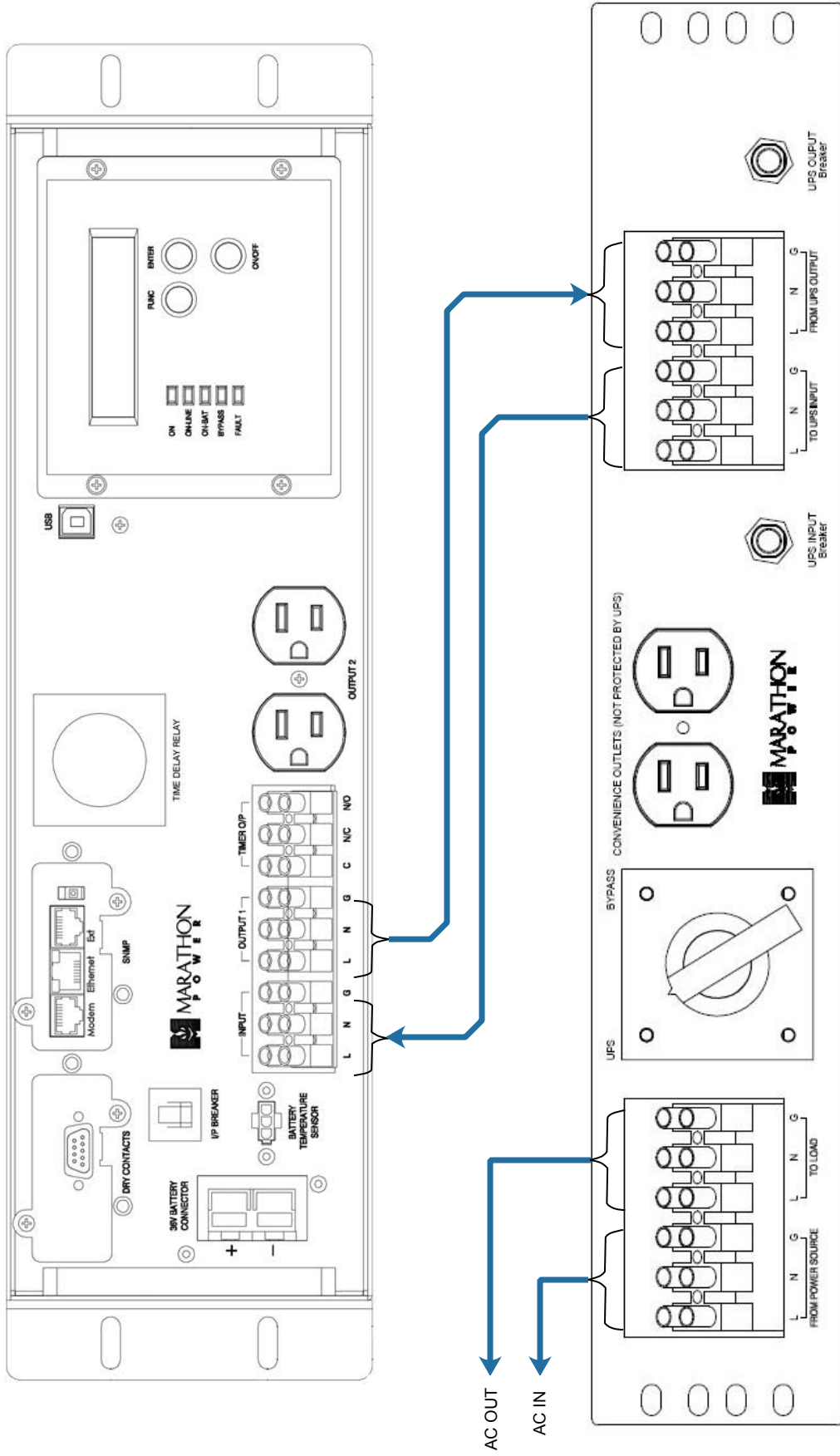

UPS Wiring Diagram with Power Transfer Switch (PTS)



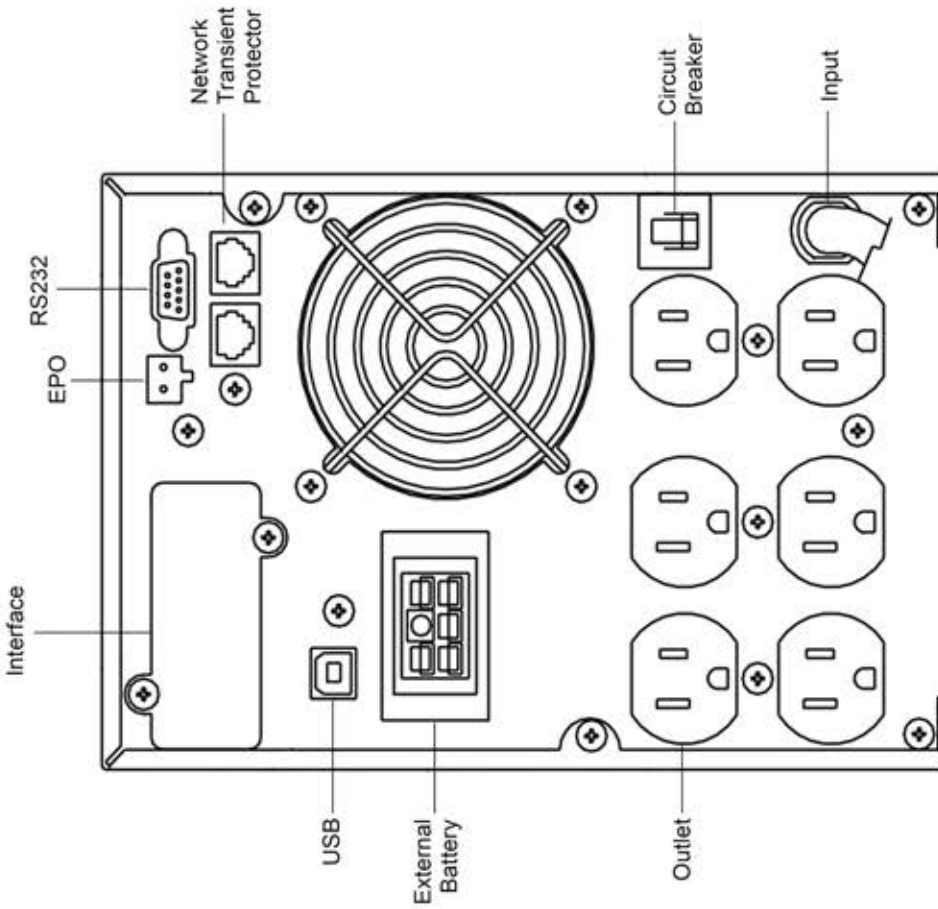

Tower 120V NEMA Rear View and Connections

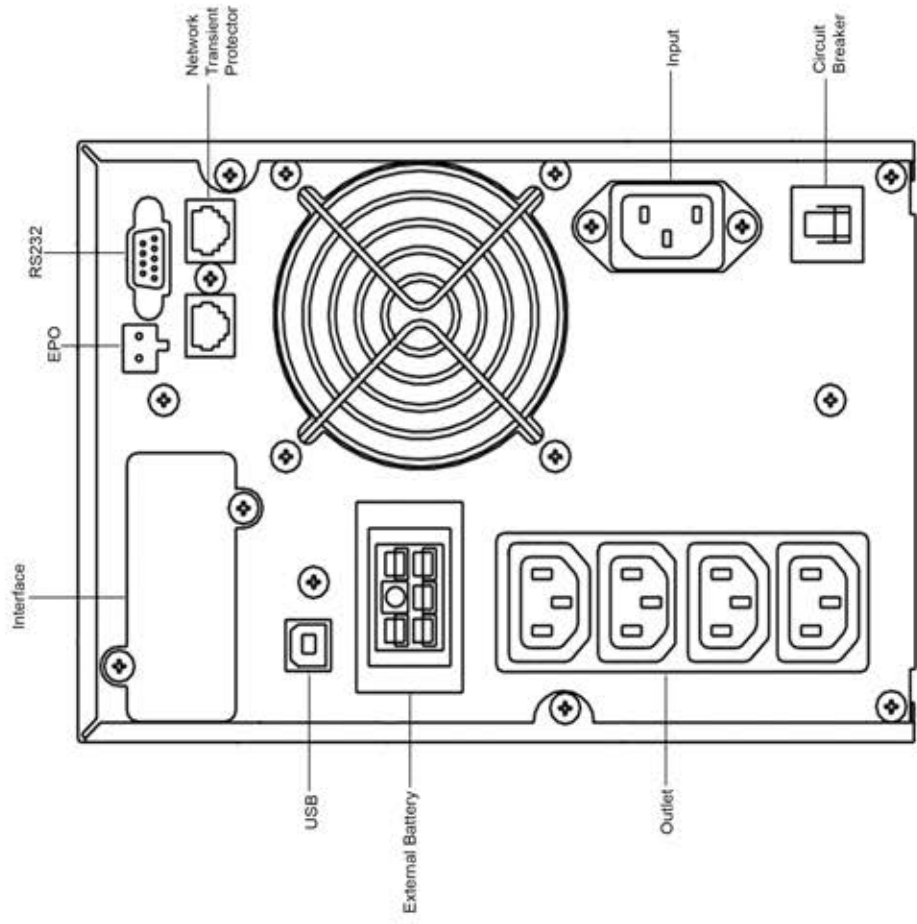

Tower 220V IEC Rear View and Connections

## 6. Operational Instructions

### 6.1 Starting Up and Shutting Down the UPS

#### Start Up

1. Ensure that the unit has been correctly installed and that the input power cable is connected to a properly grounded AC outlet.
2. The unit is turned on by pushing the power push-button on the front panel for more than 3 seconds.
3. The unit sequences through its functional check, AC line synchronization and inverter startup. Power is then applied to the outlets.
4. During this sequence, the LCD panel displays "Ready On". An LED illuminates when output power is available and the LCD panel displays "Line mode".
5. The loads can now be turned on.

#### Shut Down

1. Shut down and turn off all connected loads.
2. Push the power push-button on the front panel for five seconds or more. An audible alarm will sound and the unit will shut down.
3. The LCD panel displays "UPS OFF" for a few seconds.
4. In emergency situations or applications which require such, the EPO located on the back of the tower models and the right side of rack-mount models.





### 6.2 Push-button Operations

There are three operational push-buttons on the front panel:

1. **Power** - This push-button turns the unit on and off. To initiate a start-up or shut-down, press and hold this push-button for 3 seconds.
2. **Enter** - This push-button is used to check current UPS and load settings, information and power measurements. To activate, press it for at least 2 seconds. There are 15 different readings that can be checked in this mode and pressing this push-button once each time scrolls through each reading. If the push-button is not pressed within 5 seconds, the display reverts to its original mode.
3. **Function/Scroll** - This push-button selects or enables various user-selectable parameters. There are 14 different parameters which can be scrolled through. To activate, press it for at least 2 seconds. After locating a setting or particular parameter, press the Enter push-button to select that parameter and view its current setting. Press the Function push-button once again to scroll through the setting options. Once the desired setting is located, press the Enter push-button to enable the new setting and once again to save it (you will be prompted to do so). If no action is taken within 10 seconds, the display reverts to its previous mode.

### 6.3 Control Panel Indicators

Status, parameters and readings are displayed on the control panel via five LED indicators and/or an LCD screen and audible alarms compliment the display.

- ON**            This symbol is accompanied by a green LED that illuminates when the UPS has been turned on.
- ON-LINE**            This symbol is accompanied by a green LED that illuminates when the UPS is in normal or static bypass mode and AC voltage is present at the output terminals.
- ON-BAT**            This symbol is accompanied by a yellow LED that illuminates when the UPS is operating in battery mode.
- BYPASS**            This symbol is accompanied by a yellow LED that illuminates when the UPS is operating in bypass mode.
- FAULT**            This symbol is accompanied by a red LED that illuminates if an internal UPS error occurs. An audible alarm also sounds but can be muted by pressing any of the push-buttons on the front panel.

### Front Panel Display

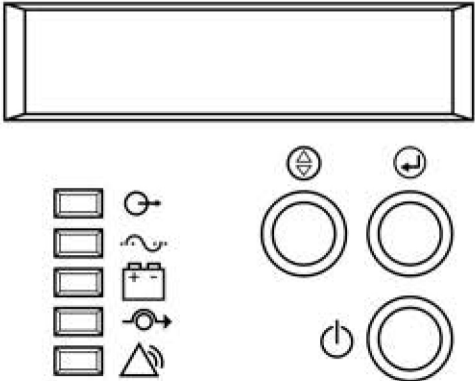



## 6.4 LCD Panel Display Modes

### 1. Normal Display Mode

UPS status is shown in this display mode. From this mode, the UPS data display mode and the setting display mode can be selected by pressing the appropriate push-button.

### 2. Data Display Mode

Various data and measurements are shown in this display mode. Pressing the Enter push-button (for 2 seconds to activate) scrolls through the following data:

Parameter	Indicates
O/P VOLT = xxx,x V	Output AC voltage
O/P FREQ = xx,x Hz	Output Frequency
I/P VOLT = xxx,x V	Input AC voltage
I/P FREQ = xx,x Hz	Input Frequency
BAT VOLT = xx,x V	Battery Voltage
O/P LOAD% = xx %	Load expressed as a percentage of the maximum load
O/P W = x W	Output Watts
O/P VA = x VA	Output VA
O/P CURR = x A	Output Current
BATT COUNT = x	How many times the unit has gone into battery mode
BATT TIME = xm	How long the unit has been in battery mode (cumulative)
TEMPERATURE = xx °C	Approximate ambient temperature
RATING = xxxx VA U	UPS Rating
CPU VERSION = xx.x	CPU Version

### 3. Configuration/Setting Display Mode

1. The current UPS configuration/settings are shown in this mode.
2. To enter this, press the Function/Scroll push-button for one second. The first configuration parameter will be shown on the LCD display.
3. Press the Function/Scroll push-button to scroll through each parameter.
4. Press the Enter push-button to select the parameter.
5. Press the Function/Scroll push-button to scroll through the options for the selected parameter.
6. Press the Enter push-button to select the option. You will be prompted to save the selection, so press the Enter push-button to confirm and save your selection. See the table below for further details.
7. If no action is taken within 10 seconds, the display reverts to normal display mode.

Settings	LCD Display	Detail	Selection/Option Default	
Output Voltage	O/P Volt Set	Nominal Voltage Selection	208/220/230/240 V	230V
			100/110/115/120/127 V	110V
Input/Frequency	I/P Freq Set	Input frequency range selection when UPS is in free run mode	±2% ±5% ±7%	±5%
Input/Bypass Voltage	I/P Bypass Set	Input Voltage range selection when bypass is available	±10% +10/-15% +15/-20%	+10/-15%
Free Run Mode	Free Run Set	UPS run in Free run mode selection (unsynchronized)	ON/OFF	ON
High Efficiency Mode	HE Mode Set	Allows the UPS to run in high efficiency mode	ON/OFF	OFF
Manual Bypass Force	Manual Bypass	Forces the UPS into bypass mode. (For service only)	ON/OFF	OFF
Load Segment / Group Management	Outlet Setting	Allows Output 2 (Outlets) to be turned ON and OFF	Group 2 ON Group 2 OFF	2 ON
Initiate Battery Test	Battery Test	Detects whether battery is in good condition or not.		
Alarm Silence	Silence Set	Enables or disables alarm silencing	ON/OFF	OFF
Site Wiring Fault Alarm	Sit Fault Set	Enables or disables site wiring fault alarm	Enable /Disable	Disable
Language	Language	Selects load language	English, German, French, Spanish, Italian.	English
Generator Mode	Generator	Places UPS in generator mode ***	ON/OFF	OFF
RS-232 communication	RS232 Control	Enables or disables RS-232 communication capability	Enable/Disable	ENABLE

## 6.5 Manual UPS or Battery Test

A manual UPS or battery test can be initiated from the UPS configuration/settings display and can be carried out even when the UPS is not charging the battery. To initiate, scroll through the parameters until Manual Bat test is displayed on the LCD panel. Press the Enter push-button twice.

\*\* NOTE: In order for the UPS and power management software to function correctly, Manual Bypass should always be set to OFF as the load will not be protected by the UPS when Manual Bypass is ON.

\*\*\* NOTE: The UPS should be turned off but kept connected to the AC power supply before activating the Generator Mode.

## 6.6 Audible Alarms

1. If the UPS is on battery and the “ON BATTERY” LED is illuminated, the unit will beep every 5 seconds.
2. If the battery capacity is low and the “ON BATTERY” LED is flashing, the unit will beep twice every 5 seconds.
3. If the UPS is in bypass mode and the “BYPASS” LED is illuminated, the unit will not beep.
4. If the UPS has an internal fault and the “ALARM” LED is illuminated, the unit will emit a constant alarm tone and display the cause of the fault on the LCD panel.
5. To silence an alarm, press any of the three push-buttons on the front panel. The alarm will be silenced under all conditions except when the battery is low, under which condition the alarm cannot be silenced.
6. The audible alarm function can be de-activated internally by selecting the appropriate parameter from the LCD panel.

## 6.7 Time Delay Relay Controller

The Time Delay Relay Controller provides a dry contact, control signal that delays the opening or closing of the normally open or normally closed timer relay terminals when the UPS is in back-up mode.

The first step in setting the time delay relay is to insure that the mode is set to the “A” position. Then use the table below to set the desired maximum time duration needed.

**Important Note: When the red light is flashing the timer is counting down.**

### DIP Switch Settings

1M =	1 Minute
10M =	10 Minutes
1H =	1 Hour
10H =	10 Hours

Contact Rating:  
Maximum Rating 250V 5A

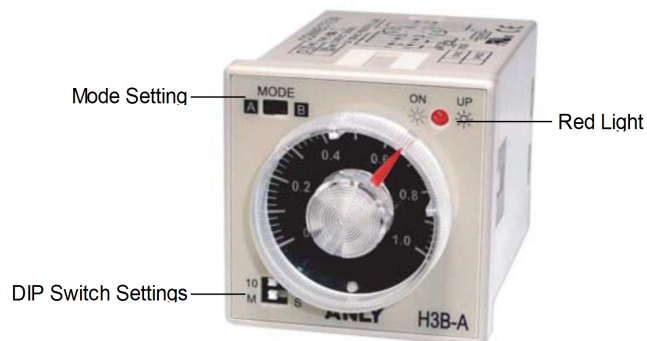

## 6.8 Maintenance Bypass Procedure

### WARNING!

Failure to follow these instructions may result in permanent damage to the UPS

MAINTENANCE BYPASS PROCEDURE (for Models without an Input Breaker)





#### 1. Maintenance

- 1 Press the ON/OFF button to turn the UPS ON and it will go into "Line Mode".
- 2 Press the "Func" button on the front panel and hold for 3 seconds, then release, the UPS will go into "Function Setting Mode".
- 3 Toggle the "Func" button until the display shows "Manual Bypass" function and then press the "Enter" button to select it. The display will indicate "Bypass OFF".
- 4 Toggle the "Func" button again, the display will show "Bypass ON". Press the "Enter" button and this will put the UPS into "Manual Bypass mode".
- 5 Once the display indicates "Manual Bypass", rotate the "Bypass Switch" on the PTS from "UPS" position to "BYPASS" position.
- 6 Turn the UPS OFF.
- 7 Wait until the fan stops and then start maintenance work.

#### 2. Restore

- 1 Press the ON/OFF button to turn the UPS ON and it will go into "Manual Bypass Mode".
- 2 Rotate the "Bypass Switch" on the PTS from the "BYPASS" position to the "UPS" position.
- 3 Press the "Func" button on the front panel and hold for 3 seconds, then release, the UPS will go into "Function Setting Mode".
- 4 Toggle the "Func" button until the display shows "Manual Bypass" function and then press the "Enter" button to select it. The display will indicate "Bypass OFF".
- 5 Toggle the "Func" button again, the display will show "Bypass OFF". Press the "Enter" button and this will put the UPS back into "Line mode".

## 7. Batteries & Maintenance

<b>⚠ DANGER</b>			
 <p><b>HIGH VOLTAGE... RISK OF SHOCK. DO NOT TOUCH UNINSULATED TERMINALS OR CONNECTORS.</b></p>	 <p><b>SHIELD EYES EXPLOSIVE GASES CAN CAUSE BLINDNESS OR INJURY.</b></p>	 <p><b>NO • SPARKS • FLAMES • SMOKING</b></p>	 <p><b>SULFURIC ACID CAN CAUSE BLINDNESS OR SEVERE BURNS.</b></p>
 <p><b>FLUSH EYES IMMEDIATELY WITH WATER.  GET MEDICAL HELP FAST.</b></p>		<p><b>DO NOT REMOVE VENT VALVE. WARRANTY VOID IF VENT VALVE IS REMOVED.</b></p>	
<p><b>SEE INSTALLATION, MAINTENANCE AND OPERATION INSTRUCTIONS FOR IMPORTANT SAFETY PRECAUTIONS.</b></p>		<p><b>REPAIR SHOULD BE PERFORMED ONLY BY A QUALIFIED SERVICE TECHNICIAN.</b></p>	

**BATTERIES  
AND OTHER RELATED PARTS  
CONTAIN LEAD**

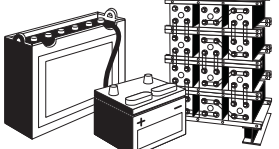

**WARNING:**  
Battery posts, terminals and related accessories  
contain lead and lead compounds, chemicals  
known to the State of California to cause  
cancer and reproductive harm.  
Batteries also contain other chemicals known  
to the State of California to cause cancer.  
**WASH HANDS AFTER HANDLING!**

Form No. 1214 Rev. 0/08. Read or postcard your address.

### California Proposition 65 Warning

Batteries, battery posts, terminals and related accessories contain lead and lead compounds, and other chemicals known to the state of California to cause cancer and birth defects or other reproductive harm. **Wash hands after handling.**

## SAFETY PRECAUTIONS

Although all valve-regulated batteries have the elec-trolyte immobilized within the cell, the electrical hazard associated with batteries still exists. **Work performed on these batteries should be done with the tools and the protective equipment listed below.** Valve-regulated battery installations should be supervised by personnel familiar with batteries and battery safety precautions.

**WARNING: Risk of fire, explosion, or burns. Do not disassemble, heat above 40°C, or incinerate.**

### 7.1 Protective Equipment

Valve regulated batteries can vent or leak small amounts of electrolyte, electrical safety is the principle but not the only concern for safe handling. Per IEEE 1188 recom-mendations, the following minimum set of equipment for safe handling of the battery and protection of personnel shall be available:

- **Safety glasses with side shields, or goggles, or face shields as appropriate. (Consult application specific requirements)**
- Electrically insulated gloves, appropriate for the installation.
- Protective aprons and safety shoes.
- Portable or stationary water facilities in the battery vicinity for rinsing eyes and skin in case of contact with acid electrolyte.
- Class C fire extinguisher.
- Acid neutralizing agent.
- Adequately insulated tools.
- Lifting devices of adequate capacity, when required.

## Procedures

**Consult User Manual of specific application for additional Safety & Operating requirements.**

The following safety procedures should be followed during installation: **(Always wear safety glasses or face shield.)**

1. These batteries are sealed and contain no free electrolyte. Under normal operating conditions, they do not present any acid danger. However, if the battery jar or cover is damaged, acid could be present. **Sulfuric acid is harmful to the skin and eyes. Flush affected area with water immediately and consult a physician if splashed in the eyes. Consult MSDS for additional precautions and first aid measures.**
2. Prohibit smoking and open flames, and avoid arcing in the immediate vicinity of the battery.
3. Do not wear metallic objects, such as jewelry, while working on batteries. Do not store uninsulated tools in pockets or tool belt while working in vicinity of battery.
4. Keep the top of the battery dry and clear of all tools and other foreign objects.
5. Provide adequate ventilation as regulated by Federal, State and Local codes and follow recommended charging voltages.
6. Extinguishing media: Class ABC extinguisher. **Note:CO2 may be used but not directly on the cells due to thermal shock and potential cracking of cases.**
7. **Never** remove or tamper with pressure relief valves. Warranty void if vent valve is removed.
8. Inspect all flooring and lifting equipment for functional adequacy.

## 7.2 Receiving and Storage

### Receiving Inspection

Upon receipt, and at the time of actual unloading, each package should be visually inspected for any possible damage or electrolyte leakage. If either is evident, a more detailed inspection of the entire shipment should be conducted and noted on the bill of lading. Record receipt date, inspection data and notify carrier of any damage.

### Unpacking

1. **Always wear eye protection.**
2. Check all batteries for visible defects such as cracked containers, loose terminal posts, or other unrepairable problems. Batteries with these defects must be replaced.
3. Check the contents of the package against the packaging list. Report any missing parts or shipping damage to your Battery Supplier.
4. Never lift batteries by the terminal posts.
5. Always lift batteries by the bottom or use the lifting handles.

## Storage

1. Batteries should be stored indoors in a clean, level, dry and cool location. Recommended storage temperature is 0°F to 90°F (– 18°C to 32°C).
2. Stored lead-acid batteries self discharge and must be given a charge six months from date of manufacture to prevent permanent performance degradation. Record dates and conditions for all charges during storage.
3. Recommended charge during storage is at a constant voltage of 13.80V (6.90V for 6V battery) for 24 hours at 77°F (25°C).
4. Do not store beyond 12 months.

## 7.3 Installation

### General

Caution should be taken when installing batteries to insure no damage occurs. The battery cabinet, tray, rack, etc. shall be inspected for sharp edges that could cause damage to the battery casing. Batteries shall not be dropped, slid, placed on rough or uneven surfaces such as tray lips or grated flooring. Mishandling of batteries could result in equipment damage or human injury. East Penn will not be liable for damage or injury as a result of mishandling or misuse of the product.

### Grounding

When grounding the battery system, proper techniques should be applied per electrical standards, such as NEC and/or local codes, as well as User Manual of specific application.

## 7.4 Battery Assembly

**(Always wear eye protection.)**

1. Set up the batteries so that the positive post (+) of one battery is connected to the negative post (–) of the next battery for all series connections.
2. All battery electrical contact surfaces shall be cleaned by rubbing gently with a non-metallic brush or pad before installing connectors. No-Ox-ID grease can be used but is not required.
3. Install all electrical connectors / cables and bolting hard-ware loosely to allow for final alignment of batteries. Torque to manufacturer recommendations.
4. After torquing, read the voltage of the battery string to ensure the individual batteries are connected correctly. The total voltage should be approximately equal to the number of batteries times the measured voltage of one battery (when connected in series). If the measurement is less, recheck the connections for proper voltage and polarity.
5. Read and record connection resistance and note the method of measurement. This helps determine a satisfactory initial installation and can be used as a reference for future maintenance requirements. **See Appendix B, recording forms, in the back of the manual. Clean, remake and remeasure any connection having a resistance measurement greater than 10% of the average of all the same type of connections.**
6. Battery performance is based on the output at the battery terminals. Therefore, the shortest electrical connections between the battery system and the operating equipment results in maximum total system performance.

Cable size selection should be determined by current carrying requirements as well as providing a minimum voltage drop between battery system and operation equipment. Proper techniques should be applied per electrical standards, such as NEC and/or local codes. **Note: Excess voltage drop will reduce the support time of the battery system.**

## Temperature

The average battery operating temperature should not exceed 95°F (35°C) and should never exceed 105°F (40.5°C) for more than an eight-hour period. Operating at temperatures greater than 77°F (25°C) will reduce the operating life of the battery. Discharging at temperatures less than 77°F (25°C) will reduce the capacity of the battery. Please see the specifications for the batteries you are using.

## 7.5 Record Keeping

**Voltages, Temperatures & Ohmic Readings Consult User Manual of specific application for additional Safety & Operating requirements.**

Record keeping is an important part of battery maintenance and warranty coverage. This information will help in establishing a life history of the battery and inform the user if and when corrective action needs to be taken. (Refer to Appendix B, Battery Maintenance Report).

After installation and the batteries are at a fully charged condition, the following data should be recorded:

Depending on application, some of the following recommendations may not apply.

- Battery and/or string terminal voltage
- Charger voltage
- Individual battery float / charge voltages
- Individual battery ohmic readings\*\*
- Ambient temperatures
- Terminal connections should be checked to verify all connections are properly torques. Micro-ohm readings should be taken across every connection. Refer to meter manufacturer's instructions for proper placement of probes. If any reading differs by more than 20% from its initial installation value, re-torque the connections. If the reading still remains high, clean contact surfaces according to installation portion of this manual.

**\*\* Note: To provide accurate / consistent values, battery(ies) must be fully charged, at same temperature and probes placed at same location each time readings are taken.**

## 7.6 Maintenance

Always wear eye protection when working on or near batteries. Keep sparks and open flames away from batteries at all times.

**Consult User Manual of specific application for additional Safety & Operating requirements.**

### Quarterly Inspection

Depending on the application, some of the following recommendations may not apply.



1. Conduct a visual inspection of the battery(ies).
  2. Record battery and /or string voltage. The accuracy of the DMM (Digital Multimeter) must be 0.05% (on dc scale) or better. The DMM must be calibrated to NIST traceable standards. Because voltage readings are affected by discharge and recharges, for cyclic applications, the battery(ies) must be in a fully charged condition prior to taking readings. Batteries should be within  $\pm 0.30$  volts (+ 0.15 volts for 6V) of the average battery float voltage.
  3. Record charger voltage.
  4. Record the ambient temperature.
  5. Record individual battery ohmic readings.\*\*\*
  6. Record all interunit and terminal connection resistances. Micro-ohm readings should be taken during this inspection. If any reading is greater than 20% from initial readings, retorque the connection. Recheck the micro-ohm reading. If the reading remains high, clean contact surface according to installation portion of this manual.
- \*\*\* Note: To provide accurate / consistent values, battery(ies) must be fully charged, at same temperature and probes placed at same location each time readings are taken.**

### **Battery Cleaning**

Batteries, cabinets, racks, and modules should be cleaned with clean water. If neutralizing is required, use a mixture of baking soda and water. Use clean water to remove baking soda residue. Never use solvents to clean the battery(ies).

**APPENDIX B**

MARATHON POWER

**BATTERY MAINTENANCE REPORT**

Inspection Date \_\_\_\_\_  
 Company \_\_\_\_\_  
 Address \_\_\_\_\_  
 Battery location and/or number \_\_\_\_\_

No. of Units/String \_\_\_\_\_  
 Type \_\_\_\_\_  
 Date New \_\_\_\_\_  
 Date Installed \_\_\_\_\_

**Individual  
Battery Readings**

Charger Output \_\_\_\_\_ Amp      Air Temperature \_\_\_\_\_ °F  
 Total Battery String Voltage \_\_\_\_\_      Panel Meter Volts \_\_\_\_\_

Year Unit Number	Volts	Ohms or Mhos	Year Unit Number	Volts	Ohms or Mhos	Year Unit Number	Volts	Ohms or Mhos	Year Unit Number	Volts	Ohms or Mhos
1			1			1			1		
2			2			2			2		
3			3			3			3		
4			4			4			4		
5			5			5			5		
6			6			6			6		
7			7			7			7		
8			8			8			8		
9			9			9			9		
10			10			10			10		
11			11			11			11		
12			12			12			12		
13			13			13			13		
14			14			14			14		
15			15			15			15		
16			16			16			16		
17			17			17			17		
18			18			18			18		
19			19			19			19		
20			20			20			20		
21			21			21			21		
22			22			22			22		
23			23			23			23		
24			24			24			24		
25			25			25			25		
26			26			26			26		
27			27			27			27		
28			28			28			28		
29			29			29			29		
30			30			30			30		
31			31			31			31		
32			32			32			32		
33			33			33			33		
34			34			34			34		
35			35			35			35		
36			36			36			36		
37			37			37			37		
38			38			38			38		
39			39			39			39		
40			40			40			40		
Avg. Voltage			Avg. Voltage			Avg. Voltage			Avg. Voltage		

Readings Taken By \_\_\_\_\_ Remarks/Recommendations \_\_\_\_\_

*Readings should be taken at installation and annually thereafter.*

## 7.7 Troubleshooting

LCD	Alarms	Problem Description	Corrective Action
Output Overload	Two beeps per second	The UPS is overloaded (in Line Mode). The power rating of the connected equipment exceeds the capacity (VA rating) of the UPS. The UPS operates in bypass mode.	Reduce the load on the UPS by disconnecting less critical equipment. Once the total load is below the maximum specified by the UPS, it will switch from bypass back to normal mode.
Battery Test	No audible tone	The UPS is performing a battery test.	No action required. The UPS will resume normal operation once the battery test has been successfully completed.
Over-Charge	Constant audible tone	The batteries have been over-charged.	Turn off protected loads, then turn off the UPS and contact tech support.
Low Battery	Two beeps every 5 seconds	The unit is operating on battery power but will shut down shortly due to low battery voltage.	Initiate a controlled shutdown of connected equipment immediately. The UPS will restart automatically once AC power has been restored.
On-Battery	One beep every 5 seconds	The unit is operating on battery power.	No action required. A controlled shutdown of connected equipment can be initiated if necessary.
Charger Failure	Constant audible tone	Battery charger failure.	Turn off protected loads, then turn off the UPS and contact tech support.
Over-Temperature	Constant audible tone	High ambient temperature.	Check that the UPS cooling fans and ventilation holes are not blocked. Check that the ambient temperature surrounding the UPS is not above 104°F (40°C). If these conditions do not exist but the problem persists, contact tech support.
Output Short Circuit	Constant audible tone	Output short circuit.	Turn off protected loads, then turn off UPS and contact tech support.
High Output Voltage	Constant audible tone	Output voltage too high.	Turn off protected loads, then turn off UPS and contact tech support.
Low Output Voltage	Constant audible tone	Output voltage too low.	Turn off protected loads, then turn off UPS and contact tech support.
Bus Fault	Two beeps per second	Internal DC bus voltage too high.	Turn off protected loads, then turn off UPS and contact tech support.
Site Wiring Fault	One beep per second	Incorrect AC power connection polarity. Ground connection missing or faulty.	Have the wiring fault corrected or alternately, disable the related alarm on the UPS
Line Abnormal	One beep per second	Incorrect AC Line backed up during auto restart.	Connect correct AC power line.

FOR ADDITIONAL ASSISTANCE, PLEASE CONTACT US AT 310-689-2328 OR [SUPPORT@MARATHON-POWER.COM](mailto:SUPPORT@MARATHON-POWER.COM)

## 8. Maintenance

As long as all the installation, environmental and operational requirements have been followed and met, the UPS will require little or no maintenance for many years. The batteries are the only component that should eventually need replacing. Their useful life depends primarily on the following two factors; the ambient temperature of the environment in which the UPS is located and the number of times they're called into use (i.e. discharged). In both cases, the lower the number, the longer they will last. A test of the UPS and batteries should be carried out at regular intervals (every 3 months) to verify that back-up time is still adequate for the application. The batteries should also be charged every six months if it is kept in storage unused.

### 8.1 Battery Replacement



**WARNING!** Batteries may cause electrical shock or burn from high short circuit currents. Please observe the following precautions when working with them:

1. Remove jewelry and metal objects such as watches and rings.
2. Use tools that have insulated handles.
3. Prevent tools and other metal objects from coming into contact with the batteries.
4. Batteries can pose an electric energy hazard. Do not rewire, modify, or change any battery wiring or connections. Such modifications can cause serious injury and/or damage.
5. Replace with the same type, rating and quantity as the original batteries.
6. Do NOT disconnect the batteries while the UPS is in Battery mode.

### 8.2 Storage Requirements

Store the UPS covered, upright and in a cool, dry location, with its battery fully charged. Before storing, charge the UPS for at least 8 hours. During extended storage in environments where the ambient temperature is +5 to +86°F (-15 to +30°C), charge the UPS's battery every 6 months. During extended storage in environments where the ambient temperature is +86 to +113°F (+30 to +45°C), charge the UPS's battery every 3 months.

## 9. Specifications

### Rack Mount Model Specifications

GENERAL			
Model Number	VRRN-0700-H1	VRRN-1000-H1	VRRN-1500-H1
Rated Capacity	700VA / 490W	1000VA / 700W	1500VA / 1050W
Technology	True on-line, double conversion topology with integral automatic bypass		
INPUT			
Phase	Single phase plus ground		
Bypass Voltage	96 – 138 VAC (user selectable)		
Input Voltage Range	60 / 70 / 80VAC – 144 VAC (60V @ 40%, 70V @ 70%, 80V @ 100% load)		
Frequency	50 / 60 Hz Auto sensing		
AC Frequency Range	45 – 65 Hz		
Input Current (120V)	5.8A	8.2A	12.4A
Input Power Factor	0.97		
OUTPUT			
Output Voltage	110 / 115 / 120/ 127 VAC		
Voltage Regulation	± 2%		
Voltage Distortion	< 5% THD with non-linear loads, < 3% THD with linear loads		
Frequency Regulation	± 0.25 Hz (while on battery or in free run mode)		
Dynamic Response	± 9 % max from 100% to 20 % or from 20% to 100 % linear load		
Overload Capacity	100 – 125% for 1 min, 125 – 150 % for 10 sec		
Efficiency	Greater than 93% (HE Mode), Greater than 88% (On-line Mode)		
Crest Factor	3 : 1		
PHYSICAL			
Input (AC) Connection	Hardwire Terminals		
Output (AC) Connection	Hardwire Terminals + two NEMA 5-15R		
Dimensions in /mm W x D x H	16.7 x 10 x 5.11 / 424 x 254 x 130		
Weight lbs / kg (net)	15.5 / 7	18.5 / 8.4	20.5 / 9.3
Operating Temperature Range	-20° C to +60° C / -4° F to +140° F (Optimal) -40° C to +75° C / -40° F to +167° F (Maximum)		

## Tower Model Specifications

GENERAL			
Model Number	VTRN-0700-C1	VTRN-1000-C1	VTRN-1500-C1
Rated Capacity	700VA / 490W	1000VA / 700W	1500VA / 1050W
Technology	True on-line, double conversion topology with integral automatic bypass		
INPUT			
Phase	Single phase plus ground		
Bypass Voltage	96 – 138 VAC (user selectable)		
Input Voltage Range	60 / 70 / 80VAC – 144 VAC (60V @ 40%, 70V @ 70%, 80V @ 100% load)		
Frequency	50 / 60 Hz Auto sensing		
AC Frequency Range	45 – 65 Hz		
Input Current (120V)	5.8A	8.2A	12.4A
Input Power Factor	0.97		
OUTPUT			
Output Voltage	110 / 115 / 120/ 127 VAC		
Voltage Regulation	± 2%		
Voltage Distortion	< 5% THD with non-linear loads, < 3% THD with linear loads		
Frequency Regulation	± 0.25 Hz (while on battery or in free run mode)		
Dynamic Response	± 9 % max from 100% to 20 % or from 20% to 100 % linear load		
Overload Capacity	100 – 125% for 1 min, 125 – 150 % for 10 sec		
Efficiency	Greater than 93% (HE Mode), Greater than 88% (On-line Mode)		
Crest Factor	3 : 1		
PHYSICAL			
Input (AC) Connection	Fixed power cord (std) or Hardwire Terminals (optional)		
Output (AC) Connection	6 x NEMA 5-15R (std) or Hardwire Terminals (optional)		
Dimensions in /mm W x D x H	6 x 16.5 x 9.4 / 152 x 420 x 238		
Weight lbs / kg (net)	17 / 7.7	19 / 8.6	20 / 9
Operating Temperature Range	-40° C to +60° C / -40° F to 140° F		

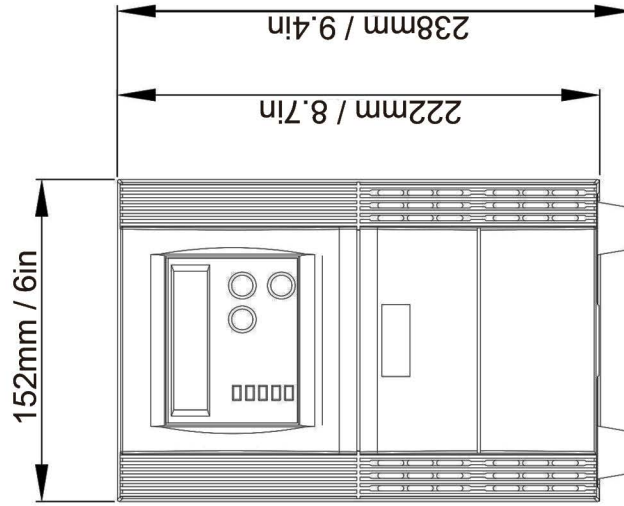
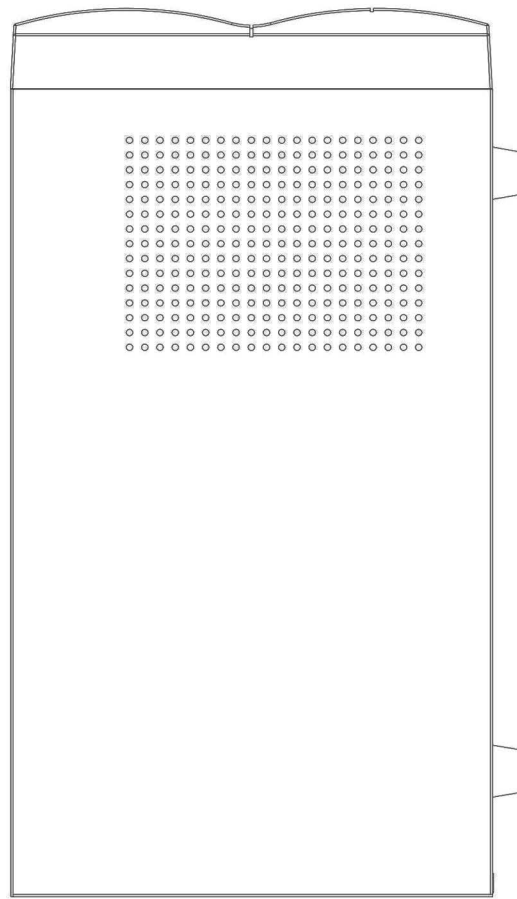
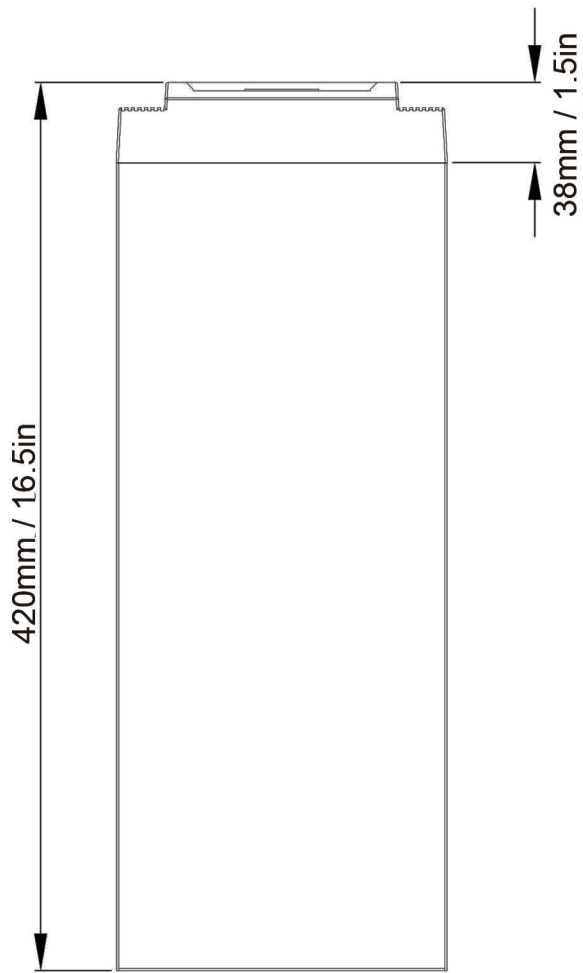

**Tower Dimensional Drawing**  
Dimensions (mm / in)

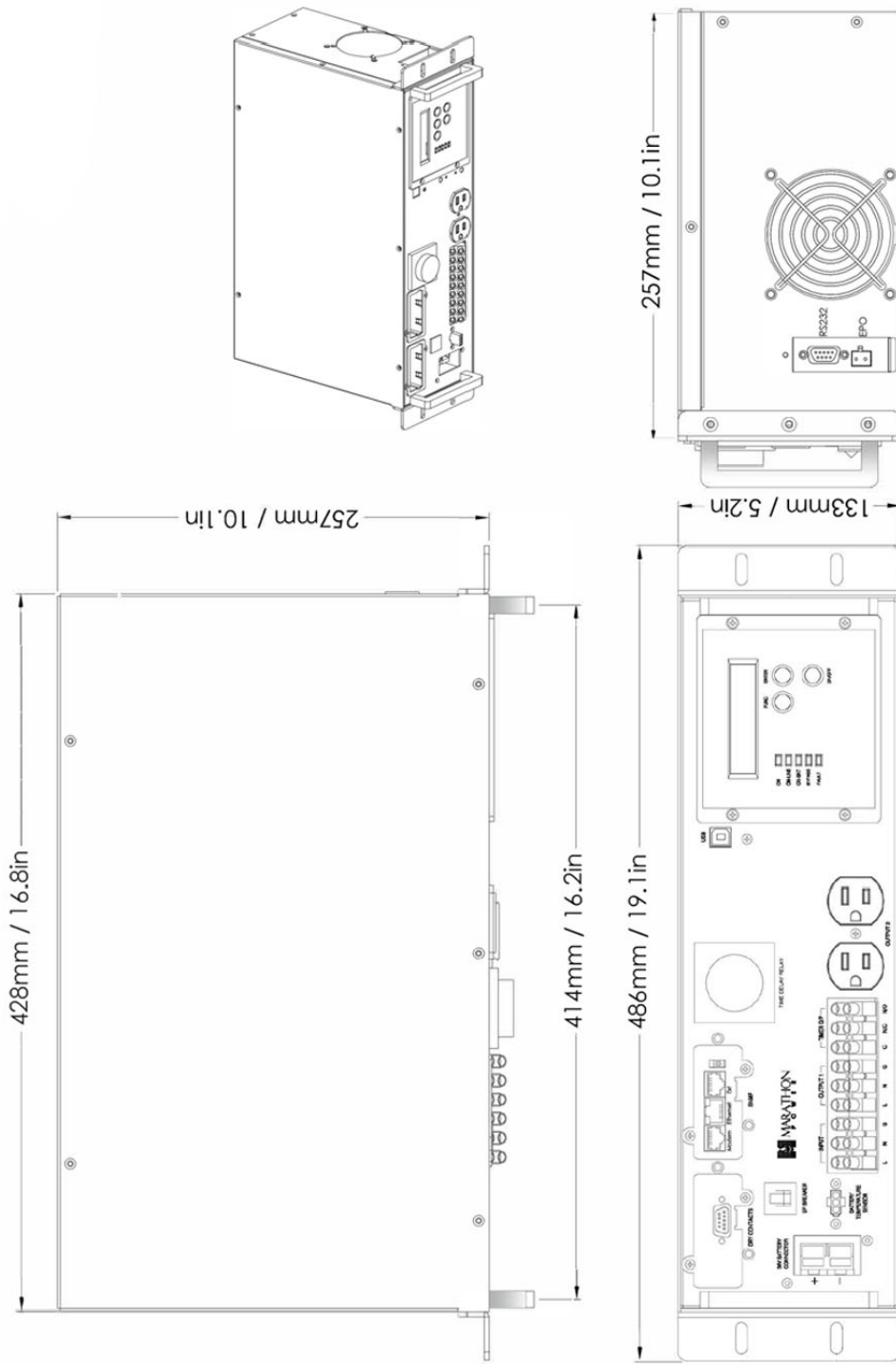

Rack Mount Dimensional Drawing





### 1. Limited Two-Year Warranty and Exclusions – Traffic & Ruggedized Models

NOTE: For this warranty to be valid, completed registration information must be received within 30 days of original purchase.

Marathon Power warrants to the original purchaser, who must have properly registered the product within 30 days of purchase, and not for the benefit of anyone else that this product at the time of its sale by Marathon Power is free of defects in materials and workmanship for two (2) years from the original purchase date. Marathon Power will correct such defects by repair or replacement, at its option, if within such two year period the product is returned prepaid and all warranty claim instructions are followed. This warranty excludes labor for removal or reinstallation of this product. This warranty is void if this product is installed improperly or in an improper environment, overloaded, misused, opened, abused, or altered in any manner, or is not used under normal operating conditions or not in accordance with all labels or instructions. There are no other or implied warranties of any kind, including merchantability and fitness for a particular purpose, but if any implied warranty is required by the applicable jurisdiction, the duration of any such implied warranty, including merchantability and fitness for a particular purpose, is limited to two years. Marathon Power is not liable for incidental, indirect, special or consequential damages, including damage to, or loss of use of, any equipment, lost sales or profits or delay or failure to perform this warranty obligation.

### 2. Limitations & Claims

This warranty does not cover any Marathon Power UPS or any properly connected electronic equipment which has been improperly installed, overloaded, abused or altered in any manner, or is not used under normal operating conditions, or in accordance with any labels or instructions, and does not cover any damage to properly connected electronic equipment.

Damage caused by failure to provide a suitable installation environment for the product (including, but not limited to, lack of a good ground) will not be covered by this warranty. This warranty does not apply to damage caused by direct lightning strikes, or damage caused by electrical disturbances that exceed published product specifications. This warranty excludes any incidental, indirect, special or consequential damages, including without limitation, labor for removal or reinstallation of the Marathon Power UPS or any connected electronic equipment, data loss or alteration loss of equipment use, lost sales or profits and any such damages for delay or failure to perform this warranty obligation. This warranty is in lieu of and excludes all implied warranties of merchantability or fitness for use. In addition, the warranty does not cover restoration of lost data and reinstallation of software. Some states may not allow the exclusion or limitation of incidental or consequential damages or other remedies, so the above exclusions or limitations may not apply to you.

Take the following steps to file a warranty claim: Contact us at Marathon Power, Inc., Attn: Returns, 2538 E. 54th Street, Huntington Park, California 90255 or call (310) 689-2328 within 30 days of the occurrence. Be prepared to provide detailed information about the event, any damage, the UPS model number, purchase date and location. You will then be provided with a Return Material Authorization (RMA), and be instructed to forward your proof of purchase (receipt), an explanation of the event and your UPS. Marathon Power is not responsible for shipping costs.





MARATHON  
P O W E R

Marathon Power Inc.

2538 E. 54th Street  
Huntington Park, CA 90255  
Office: 310-689-2328  
Fax: 310-689-2329  
[support@marathon-power.com](mailto:support@marathon-power.com)  
[www.marathon-power.com](http://www.marathon-power.com)