



TRACK SERIES

Battery Backup System for Traffic and Rugged Applications

Installation, Operation and Maintenance Manual
For Model:

TRTC-2004-N1 UPS



TRTC-2004-N1 Installation, Operation and Maintenance Manual

PLEASE NOTE THIS IS A QUICK REFERENCE GUIDE FOR SETUP AND INSTALLATION. PLEASE SEE USER MANUAL FOR FULL SAFETY INFORMATION AND INSTRUCTIONS.

SAFETY TIPS

- Carefully unpack the UPS. Report any shipping damage immediately.
- Before installation, confirm that the voltage and current requirements of the load(s) are compatible with the systems output.
- Confirm that the line voltage and current is compatible with the systems input requirements.
- The system should be installed on a dedicated power circuit.
- Use proper lifting techniques when moving the system.
- The UPS has more than one live circuit. It is fed from AC as well as battery power. Power may be present at the output(s) even if the system is disconnected from line power.
- When installing a system in a cabinet, ensure that the environment meets the system specifications.

FOR SUPPORT QUESTIONS CONTACT 310-689-2328 x 103

SAVE THE ORIGINAL SHIPPING BOX

When returning the TRTC-2004-N1 for servicing, use the original shipping box with the supplied Styrofoam protectors. Manufacturer is not responsible for damage caused by improper packaging of returned systems.

READ THE OPERATOR'S MANUAL

Before installation, become familiar with the TRTC-2004-N1 by reviewing the procedures and drawings in this manual. If you have any questions about safe installation, operation, or maintenance, contact Manufacturer customer service department.

Complete the following for records & future servicing:

Model & Serial # can be found on the nameplate label attached to the side of the unit	
Model #	TRTC-2004-N1
Serial #	
Products Sales Order #	
Purchase Order #	
Purchased from	
Telephone #	
Fax #	
E-Mail	
The following details are for installation location	
Installation date	
Installed by	
Street names	
City	
County / State	
Zip / Postal Code	
Country	

TABLE OF CONTENTS

BEFORE YOU START: SAFETY	8
Safety Symbols	8
Before Getting Started	9
System Safety Checklist	9
Battery Warnings.....	10
SECTION 1: GLOSSARY.....	11
SECTION 2: THEORY OF OPERATION	12
Intro.....	12
2.1 The Advantages.....	12
2.2 System Description	13
SECTION 3: A TOUR OF THE TRTC-2004-N1.....	14
3.1 TRTC-2004-N1 UPS.....	14
3.2 Power Transfer Switch	15
SECTION 4: INSTALLATION.....	16
4.1 Recommended Wiring	17
4.2 Connecting the Utility Line / Input Power	27
4.3 Starting Up the BBS.....	27
4.4 Testing the UPS	28
4.5 Shutting Down the UPS	29
4.6 Emergency Shutdown	30
4.7 Removing the PTS.....	31
4.8 Battery Backup Test.....	32
4.9 LCD Panel Key Functions.....	33
SECTION 5: OPERATION – LCD INTERFACE	42
5.1 LCD Panel.....	42
5.2 Operating Modes.....	43
5.3 Menu Tree and Main Screen.....	44
5.4 Status Submenu	65
5.5 Control Submenu.....	67
5.6 Settings Menu	68

5.9 Fault Menu.....	71
5.10 Event Log View.....	72
5.11 Stages of Battery Modes.....	73
SECTION 6: OPERATION – RS-232 / USB INTERFACE.....	74
6.1 RS-232 / USB Interface Info.....	74
6.2 Putty Settings.....	75
6.3 HyperTerminalSettings.....	76
6.4 Menu Tree.....	77
6.5 Main Menu.....	81
6.6 Submenus.....	83
6.7 Unit Specifications.....	83
6.8 Input / Output Values.....	84
6.9 Maintenance.....	85
6.10 Transfer Point Parameters.....	87
6.11 Transfer Point Descriptions.....	88
SECTION 7: ADJUSTMENTS.....	89
7.1 Back-UpTest.....	89
7.2 Sense Mode-Normal and Generator Waveforms.....	90
SECTION 8: MAINTENANCE	91
8.1 Trouble Shooting Sequence Chart.....	91
8.2 TRTC-2004-N1 Troubleshooting.....	2
8.3 PTS Troubleshooting	93
8.4 Alignment Procedure – Battery Backup Test	94
8.5 Battery Care.....	95
APENDICES	97
TRTC-2004-N1 Specifications	97
PTS Specifications.....	99
Transfer Point Descriptions.....	100
LCD Menu Tree	101
Return Instructions	105

SAVE THESE INSTRUCTIONS

Before You Start: Safety

IMPORTANT SAFETY INSTRUCTIONS ARE CONTAINED IN THIS MANUAL

To reduce the risk of electrical shock and to ensure the safe operation of the TRTC-2004-N1, the important safety instructions are marked with the symbols as shown below. These symbols are used throughout this manual and wherever they appear, it indicates that the instructions should only be carried out by qualified personnel.

- ❖ Safety Symbols
 - ❖ Before Getting Started
 - ❖ System Care
 - ❖ Battery Care
 - ❖ Stand-By Generator
 - ❖ Servicing
-

❖ Safety Symbols



DANGER!

Indicates presence of **DANGEROUS VOLTAGE** in the area.
Extreme caution should be used.



ATTENTION!

Indicates **ATTENTION** to important operating instructions.
Follow them as indicated.



NOTE / TIP:

Indicates additional information to assist the completion of a procedure or tips for ease of operation.

❖ Before Getting Started



DANGER!

Do not expose the TRTC-2004-N1 to rain or moisture.



DANGER!

Total Earth ground leakage current of loads connected to the TRTC-2004-N1 should not exceed 2.4 mA.



DANGER!

The TRTC-2004-N1 generates, uses and can radiate radio frequencies if not installed and tested in accordance with the instructions contained in this manual. It has been tested and found to comply with the limits established for a Class A computing device pursuant to part 15 of FCC rules when it is operated alone. It also complies with the radio interference regulations of DOC, which are designed to provide a reasonable protection against such interference, when this type of equipment is used in a commercial environment. If there is interference to radio or TV reception, which is determined by switching it on and off. Relocate the equipment or use an electrical circuit other than the one used by the TRTC-2004-N1.

❖ System Safety Checklist



DANGER!

Sealed lead-acid batteries with high energy and chemical hazards are used. This manual contains important operation and safety instructions.

- Carefully unpack the TRTC-2004-N1. Report any shipping damage at once.
- *Read this manual.* If you have any questions about safe installation, operations or maintenance of the system, contact manufacturer service department.
- *Before installation,* confirm that the voltage and current requirements of the load(s) are compatible with the system's output. Confirm that the line voltage and current is compatible with the system's input requirements.
- The system should be installed on a dedicated power circuit.
- Use proper lifting techniques when moving system.
- The TRTC-2004-N1 has more than one live circuit. It is fed from AC as well as battery power. Power may be present at the output(s) even if the system is disconnected from line power.
- When installing a system in other than a Manufacturer cabinet, ensure that the environment meets the system specifications shown in the Appendix.

❖ Battery Warnings



DANGER!

- High & **dangerous voltages** are present inside the system. Only qualified personnel should perform installation and maintenance.
- Live battery wires **must not** touch the TRTC-2004-N1 chassis or any other metal objects. ***This can cause a fire or explosion.***
- **Inspect** the batteries once a year for signs of cracks, leaks, or swelling. Replace as needed.
- When batteries are in storage, **charge** them at least once every three months for optimum performance and to extend their lifetime.
- **Always** replace batteries with the ones of identical type and rating. **Never** install old or untested batteries. **Never** mix old with new batteries. **Never** mix the different amp hour rated batteries within one system.
- Use **insulated tools** during servicing.
- **Remove** all rings, watches, jewelry, or other conductive items before working inside the enclosure.
- **Follow** local regulations for the disposal of batteries. Recycling is the best method.
- **Never** burn batteries to dispose of them. ***They may explode.***
- Do not open the batteries. ***The contents are toxic.***

Section 1: Glossary

AC	Alternating Current
ANSI	American National Standards Institute
AWG	American Wire Gage
BBS	Battery Backup System
E-BBS	External Battery Backup System Cabinet
DC	Direct Current
IEEE	Institute of Electrical and Electronics Engineers
EIA	Electronic Industries Association
ITE	Institute of Transportation Engineers
KVA	Kilovolt-Ampere
LED	Light Emitting Diode
LCD	Liquid Chrystal Display
NEMA	National Electrical Manufacturers Association
NC	Normally Close
NO	Normally Open
OD	Outside Diameter
PTR	Power Transfer Relay
UL	Underwriters Laboratories
TB	Terminal Block
THD	Total Harmonic Distortion
UV	Ultraviolet Light
VDC	Volts DC
VA	Voltage Ampere
VAC	Voltage Alternating Current

Section 2: Theory of Operation

The traffic signal cabinet is powered continuously when a TRTC-2004-N1 system is installed. The system allows connection for the normal utility power using standard terminal blocks or an optional generator power via standard 30 Amp (optional 50 Amp) generator receptacle. The optional bypass switch redirects utility power to the load and allows the TRTC-2004-N1 to be removed for service on a temporary or permanent basis without disrupting the operation of the traffic signal.

With a fully functioning UPS system, the PTS allows utility power to flow out to the traffic cabinet, when the utility line is qualified (within the acceptable range as programmed). If the UPS is not functioning, the PTS will bypass the UPS allowing the utility to flow out to the traffic cabinet. The UPS input is protected with one circuit breaker located on the PTS as well as another one located on the UPS module. When the UPS internal BOOST and BUCK is enabled, the PTS is activated allowing UPS to continuously boost the output when input is lower, buck or lower the output when input is higher or run from batteries when input power is outside the specified acceptable range. The PTS has dual NEMA power receptacles for optional battery heating pads, connecting a vacuum cleaner, or a PC for maintenance.

The smart, temperature compensated internal charger continuously monitors and maintains the batteries in a fully charged state. For the protection of the battery, the charging process is automatically discontinued when the battery temperature exceeds 50 degrees C. When the batteries are fully charged, the smart charger provides a continuously pulsating ON-OFF trickle charge to keep the batteries topped-off or fully charged. When input power is not qualified or is outside the acceptable range, the UPS derives the DC power from the storage tank of four batteries connected in series and maintains output power until the batteries are depleted down to a specified level or the utility power returns within its specified levels. The traffic intersection will continue to operate in full operation AND / OR in flash mode as programmed by the user. Programmable contacts allows the user to place the intersection in flash mode as soon as the input power is lost or after the batteries are depleted down to a certain capacity that is determined and programmed by the user. The amount of back-up time battery power can provide depends on the Amp-hour capacity of the batteries as well as the intersection watt load that requires support.

❖ 2.1 The Advantages

Advanced Power Protection Technology

TRTC-2004-N1 is an Uninterruptible Power Supply (UPS) also known as a Battery Backup System (BBS) designed for both indoor and outdoor applications. The TRTC-2004-N1 provides continuous power to traffic and signal equipment.

◆ Advanced Communications

The RS232 and/or USB ports allow for local or remote monitoring of the TRTC-2004-N1.

◆ **Smart Charging**

MP Series smart charge technology ensures the batteries are always at peak performance.

◆ **User Friendly Supervision**

The LCD panel provides “At a Glance” monitoring and control.

◆ **Service Friendly**

The batteries can be changed without shutting down the intersection loads or the TRTC-2004-N1.

❖ **2.2 System Description**

***Purpose:** Describes the operation of the TRTC-2004-N1 System.*

The TRTC-2004-N1 System provides backup power to traffic control signal equipment. It consists of the Uninterruptible Power Supply (UPS) System, the Power Transfer Switch (PTS), and batteries that provide back-up power when the line is unqualified. These three components can be mounted inside an enclosure to provide protection from most weather conditions.

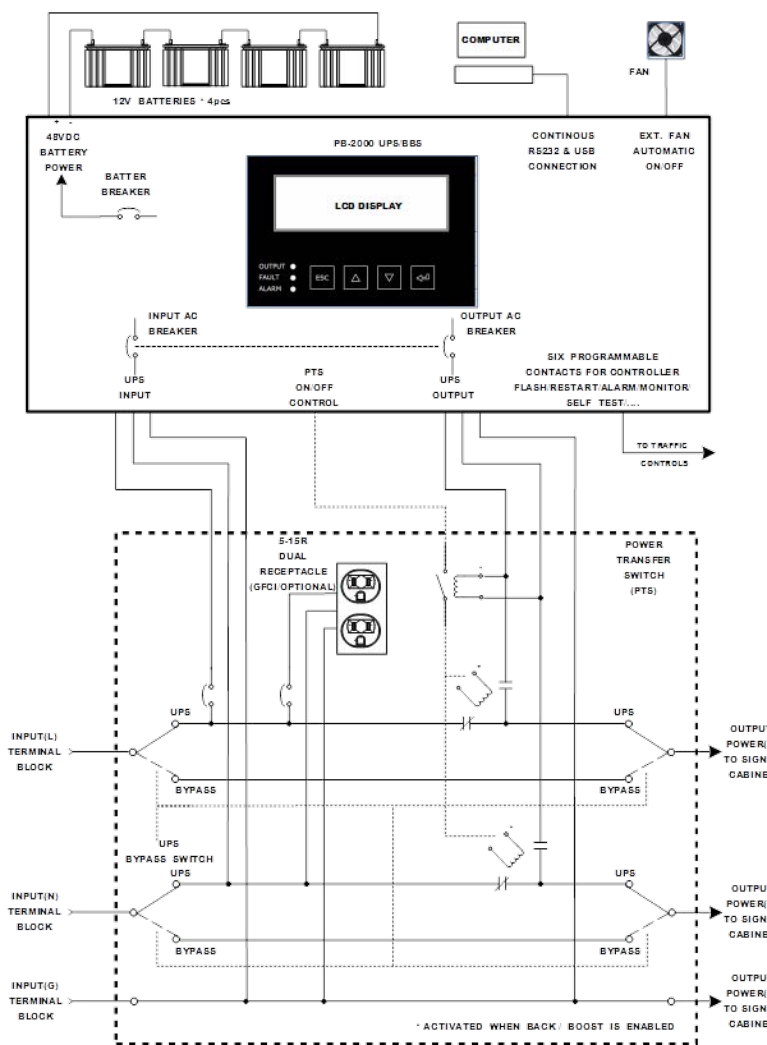

Simplified TRTC-2004-N1 System Block Diagram

Section 3: Tour of the TRTC-2004-N1 BBS

3.1 TRTC-2004-N1 UPS

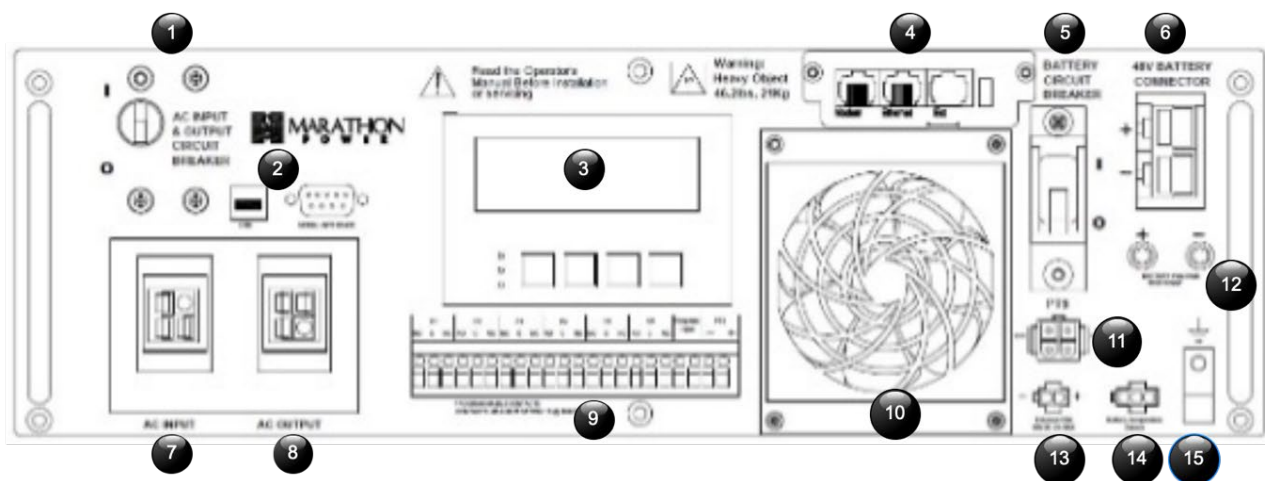

1. AC Input & Output Circuit Breaker
2. USB / Serial Interface / RS232 Connector
3. Liquid Crystal Display (LCD) Control Panel
4. SNMP Card
5. Battery Circuit Breaker
6. 48VDC Battery Connector
7. AC Input
8. AC Output
9. Dry Contact Terminal Block
10. Internal Fan
11. PTS Connector
12. Battery Voltage Test Points
13. Ext Fan 48VDC
14. Battery Temp Sensor and Strain Relief
15. Equipment Grounding Lug

3.2 Power Transfer Switch (PTS)

The Power Transfer Switch (PTS) shown below allows the UPS to be removed for service, replacement, or maintenance without interrupting power to the traffic cabinet.

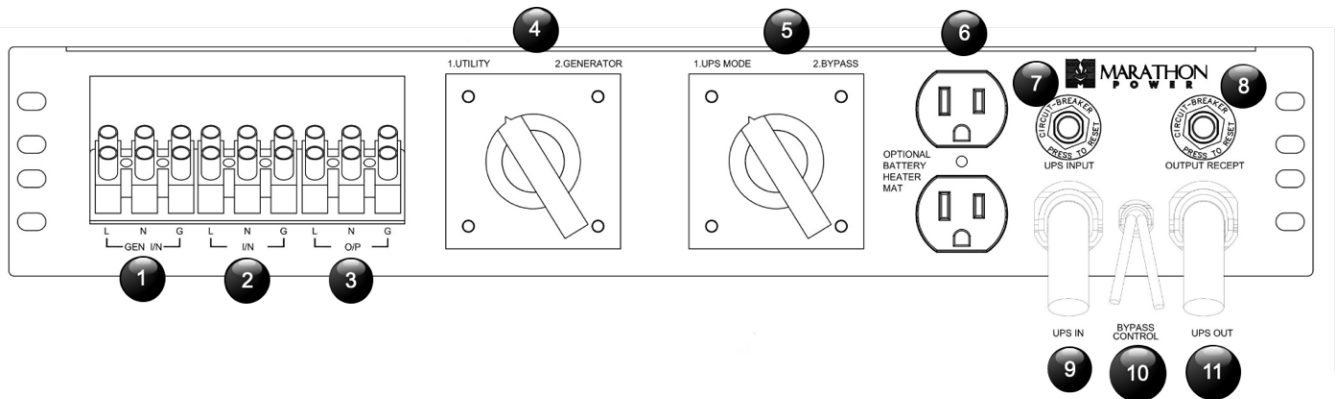

1. Generator input terminal block or receptacle
2. Utility input terminal block or receptacle
3. Equipment Output terminal block or receptacle
4. Utility / Generator switch allows switching the supply to the load between the Utility power and generator so that the generator may provide temporary electrical power if the utility source fails. (Not available on part number TSRC-2002-01).
5. Bypass/UPS switch allows the switching of the supply to the load between the incoming supply and the UPS so that the UPS can be isolated for maintenance.
6. Auxiliary output receptacle to optional battery heater mat
7. UPS input and output circuit breaker
8. PTS Control Wires
9. Output power cord to feed UPS input
- 10.ATS Bypass Control Signal
11. Input power cord output from the UPS

Section 4: Installation

Consult a licensed electrician. Follow local electrical codes.

4.1 Recommended Wiring

1. AC Input Cords
 - a. UL Style 1015 CSA TEW 6 or 10 AWG
 - b. 105 stands of 30 AWG tinned copper
 - c. Rating 600V, 105°C, PVC Insulation
2. Power Interconnects between BBS components and 332A terminal blocks and busses.
 - a. UL Style 1015 CSA TEW 10 AWG
 - b. 105 stands of 30 AWG tinned copper
 - c. Rating 600V, 105°C, PVC Insulation
3. Relay connections
 - a. Insulated UL Style CSA TEW 18 AWG
 - b. 16 stands of 30 AWG tinned copper
 - c. Rating 600V, 105°C, PVC Insulation
4. DC Battery Connectors
 - a. Two-Part Modular Harness UL Style 1015 CSA TEW or Welding Style Cable or equivalent, 6 AWG Stranded and 10 AWG Stranded

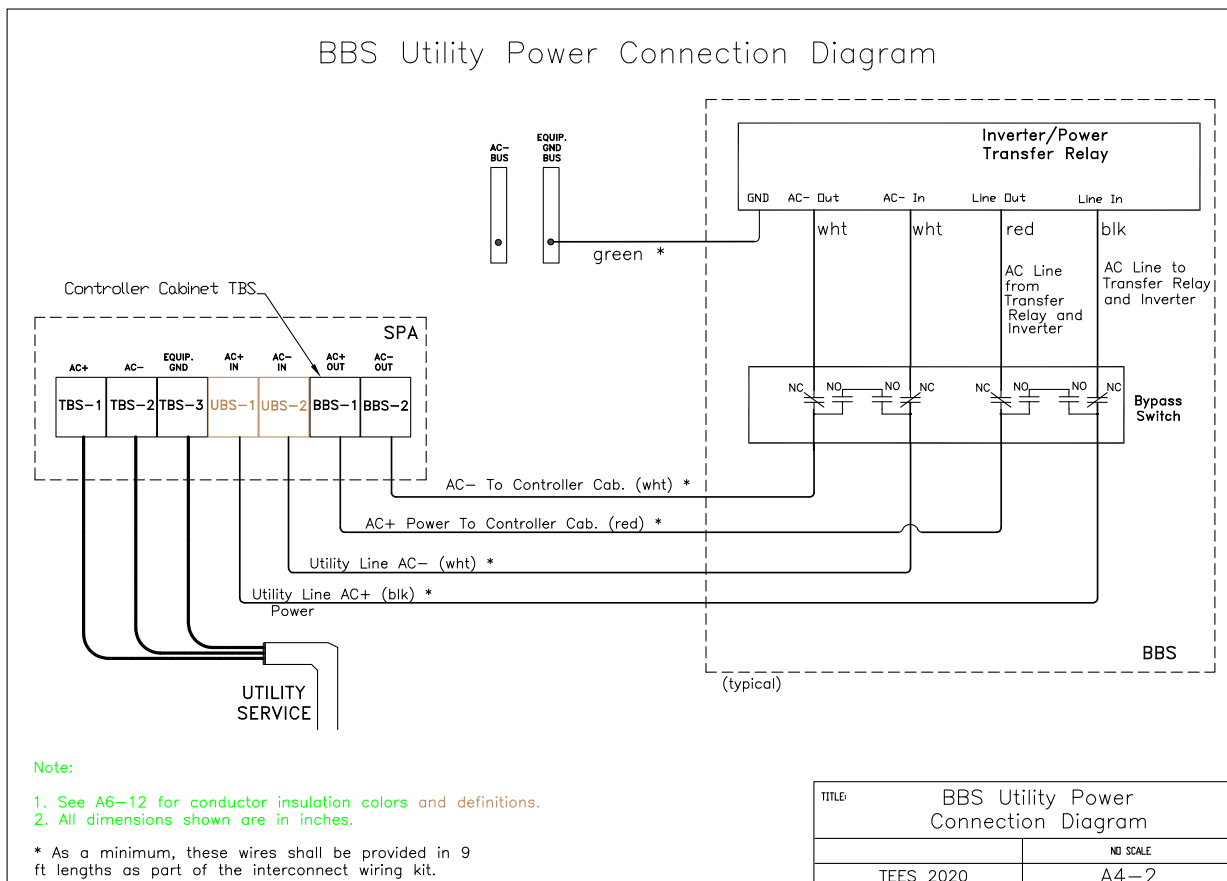

4.2 Connecting to the Utility Line / Input Power



DANGER! TRAFFIC INTERSECTION NOTE

If the installation is at an active traffic intersection, have law enforcement begin directing traffic before the power to signals is turned off.

Make sure the upstream circuit breaker for the power source is OFF before performing this step. Make sure the BATTERY CIRCUIT BREAKER on the unit is also off.

Make sure the upstream circuit breaker feeding the utility power is OFF before beginning this step. Leave the NEUTRAL and GROUND wires connected from Utility to signal cabinet. Extend the NEUTRAL and GROUND wires from their corresponding bus bars in the traffic cabinet to the correct terminal block on the PTS.

If this is a new traffic signal installation with Utility AC power going directly to UPS, ensure the upstream circuit breaker feeding the Utility Power is OFF before beginning this step. If this is an addition of a UPS to an existing traffic signal cabinet, DO NOT terminate the power cable from the signal cabinet to the UPS at the signal cabinet end until the final step after all other connections have been completed. This could minimize the length of time the traffic signals must be off for a power interruption.

There are many ways that the Utility AC can be wired into the traffic signal cabinet. This manual's intent is only to explain the proper connection of utility AC at the UPS. How the Utility AC is routed from the service entrance or through the traffic signal cabinet (hereafter referred to as the "power source") to the UPS shall be determined by a licensed electrician following local electrical codes.

The suggested method of wiring Utility AC to the UPS from the traffic signal cabinet is to connect the UPS at the traffic cabinet after the main cabinet breaker and surge suppressor. In this way, the cabinet's surge suppressor also protects the UPS.

Connect the input HOT black wire from utility to "VAC IN" on PTS. Run wires from neutral and ground bus bars of traffic cabinet to PTS neutral & ground terminal blocks.

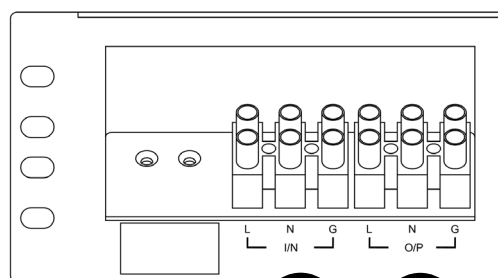

Power Transfer Switch (TSRC-2002-01) - Connecting to the Load / Output



DANGER! TRAFFIC INTERSECTION NOTE

If the installation is at an active traffic intersection, have law enforcement begin directing traffic before the power to signals is turned off.

1. Connect a black wire from the VAC Out at the PTS to the Input Hot terminal in the signal cabinet.
2. The wires from Ground and Neutral Bus Bars from the traffic cabinet are extended to PTS Terminal Block.
3. OPEN the upstream breaker feeding utility power to the signal cabinet.
4. Disconnect the HOT wire (Black) connected between utility and traffic cabinet.
5. The cabinet side HOT wire is connected to "AC OUT" on the PTS.
6. The utility side HOT wire is connected to "VAC IN" on the PTS.
7. Torque the PTS terminal block to a maximum of 10.0 lb-in (1.1 Mm).

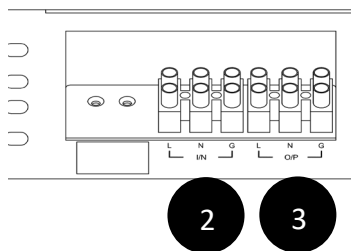

Power Transfer Switch w/ Generator Option (TSRG-2002-01) - Connecting to the Utility Line / Input Power



DANGER! TRAFFIC INTERSECTION NOTE

If the installation is at an active traffic intersection, have law enforcement begin directing traffic before the power to signals is turned off.

The PTS with Generator Option can accept power from two AC Power Sources either, one Utility Power and one Generator Power, two Utility Power sources or two generator power sources, or

What is the proper order of switching the two switches? It does not matter.

When the UPS is supplied by the Utility Power and is in Line Mode:

To change the system to Generator Power, you must turn the Manual Transfer Switch from Utility to Generator. During the transfer, the UPS may change to Battery Mode, but when the UPS senses the Generator Power, it performs an AC Input Qualification test and transfers to Line Mode. Generator Power now supplies the system.

When the UPS is in Battery Mode due to Utility Power failure:

Switching the manual transfer switch from Utility to Generator, the UPS senses the Generator Power, performs an AC Input Qualification test, and transfers to Line Mode. Generator Power now supplies the system.

IMPORTANT GENERATOR NOTE:

When Utility Power is restored, the PTS cannot return to Utility Power. The transfer between Utility Power and Generator Power is via a Manual Transfer Switch. You must manually turn the Manual Transfer Switch from Generator back to Utility. During the transfer, the UPS may change to Battery Mode, but when the UPS senses the Utility Power, it performs an AC Input Qualification test and transfers to Line Mode. Utility Power now supplies the system.

IMPORTANT: The Polarity of both AC Inputs (Utility and Generator) is correct. If the polarity of the AC Lines and Neutrals are reversed, it causes a short circuit.

IMPORTANT WARNINGS

If the Generator Neutral and Ground are not connected properly, an L/N Ground fault is possible. For example, if the Utility Power already has the Neutral and Ground connected at a source transformer, and the Generator also has the Neutral and Ground connected, the Generator Line to Neutral and Generator Neutral to Line, the L/N are shorted via the Ground connection.

If the Output is shorted when UPS is in Backup Mode, the UPS Electronic Protection was activated, and the UPS detects the Output Short Circuit.

Check to see The PTS to UPS Connections are correct. If the Input and Output Connections are reversed by mistake, this causes a conflict connection of the UPS Input and UPS Output. The UPS Output is connected to the UPS Input.

Connect the input HOT black wire from utility to "VAC IN" on PTS. Run wires from neutral and ground bus bars of traffic cabinet to PTS neutral & ground terminal blocks.

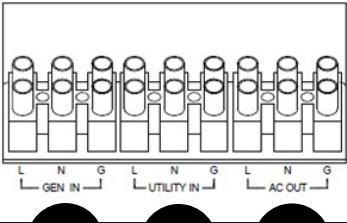

The diagram shows a three-phase terminal block with three sets of terminals. Each set has three terminals labeled L, N, and G. The first set is labeled 'GEN IN', the second 'UTILITY IN', and the third 'AC OUT'. Below the diagram are three numbered circles: 1, 2, and 3.

Power Transfer Switch (TSRG-2002-01) - Connecting to the Load / Output



DANGER! TRAFFIC INTERSECTION NOTE

If the installation is at an active traffic intersection, have law enforcement begin directing traffic before the power to signals is turned off.

1. Connect a black wire from the VAC Out at the PTS to the Input Hot terminal in the signal cabinet.
2. The wires from Ground and Neutral Bus Bars from the traffic cabinet are extended to PTS Terminal Block.
3. OPEN the upstream breaker feeding utility power to the signal cabinet.
4. Disconnect the HOT wire (Black) connected between utility and traffic cabinet.
5. The cabinet side HOT wire is connected to "AC OUT" on the PTS.
6. The utility side HOT wire is connected to "VAC IN" on the PTS.
7. Torque the PTS terminal block to a maximum of 10.0 lb.-in (1.1 Mm).

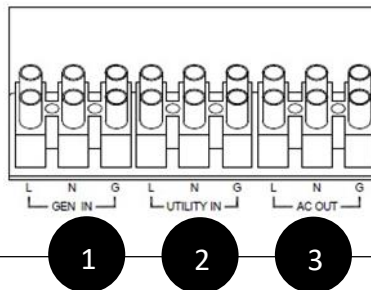

Verify the **UPSTREAM CIRCUIT BREAKER** is off.
Verify the **AC INPUT & OUTPUT CIRCUIT BREAKER** is off.
Verify the **BATTERY CIRCUIT BREAKER** is off.

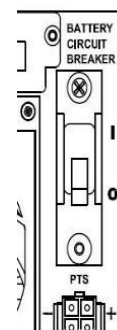
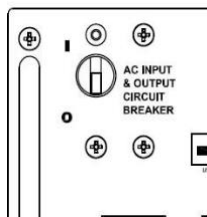

Verify the **UPS MODE / BYPASS** switch is in **BYPASS**.

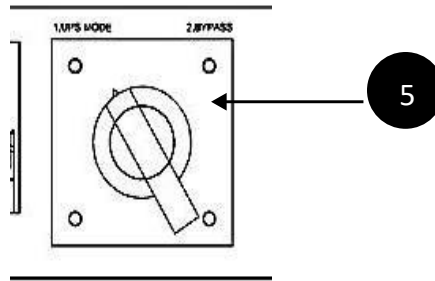

Install and Connect the Temperature Probe

NOTE: Batteries are adversely affected by heat; the Temperature Probe provides feedback to control the cooling system. The Battery Temp Probe connector must be plugged into the UPS for it to function.

IMPORTANT: Because it is easy to overlook, an unconnected Temperature Probe is the main reason that the red Alarm LED comes ON when power is applied.

1. Attach the Temperature Probe to the battery that you expect will be exposed to the most heat—for example, the battery next to the wall of the cabinet where you expect to have the most exposure to the sun. **NOTE:** Connect the ring lug connector of the Temperature Probe to the battery terminal.
2. Connect the supplied 10-foot extension cable to the Temperature Probe and route it to the UPS.

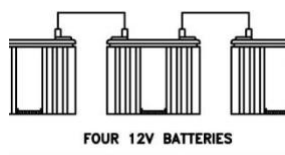

Wrap a tie around the strain relief loop and the battery temperature sensor to prevent the connector from disconnecting during an earthquake or other severe vibrations.

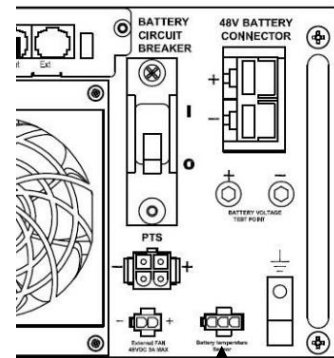

Attach **External Cabinet Fan** into the respective connector on the TRTC UPS SERIES.



Wrap a tie around the strain relief loop and the fan to prevent the connector from disconnecting during an earthquake or other severe vibrations.

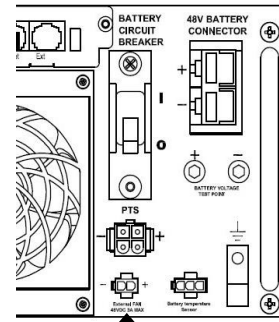

13

Connect the **BYPASS CONTROL** wires to the **PTS** connector into the TRTC UPS SERIES.

10

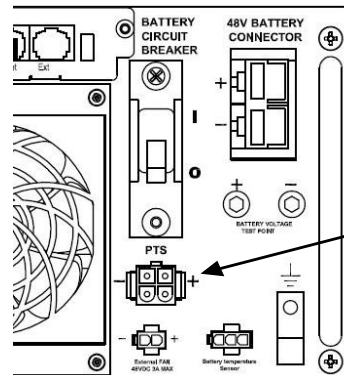
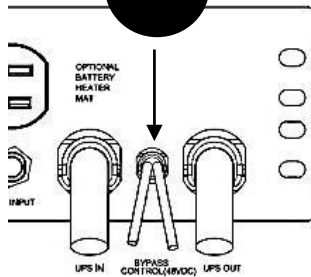

11

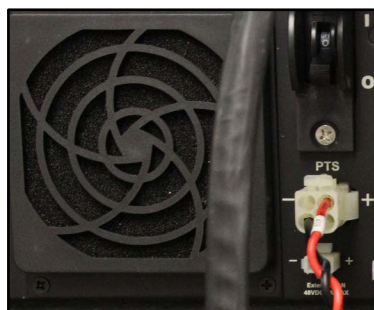

Connect the PTS **UPS IN** to the UPS **AC INPUT**.

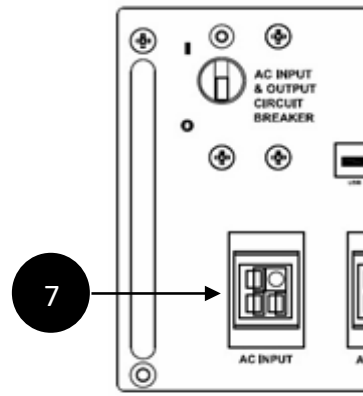
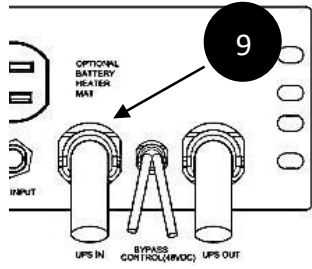

Attach PTS **UPS OUT** to the UPS **AC OUTPUT**.

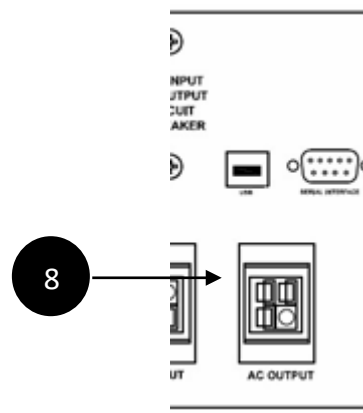
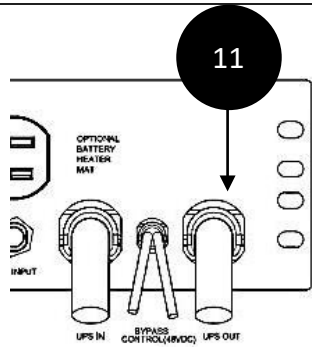

Connect the cable from the batteries to the **48V BATTERY CONNECTOR** into the TRTC UPS SERIES.

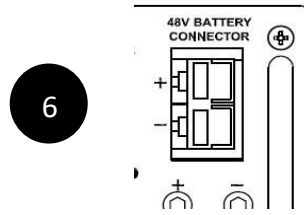

Ensure battery breaker is turned open / off. Connect four 12VDC batteries in series for a total of 48VDC.

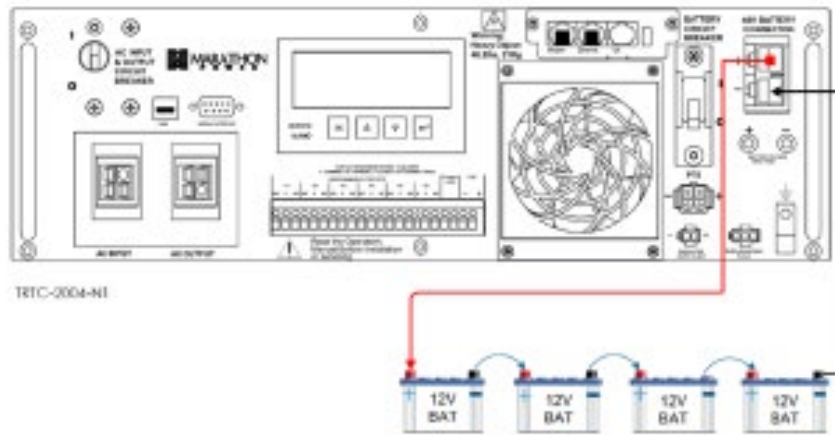

Ensure battery breaker is turned open / off. Connect four 12VDC batteries in parallel for a total of 48VDC.

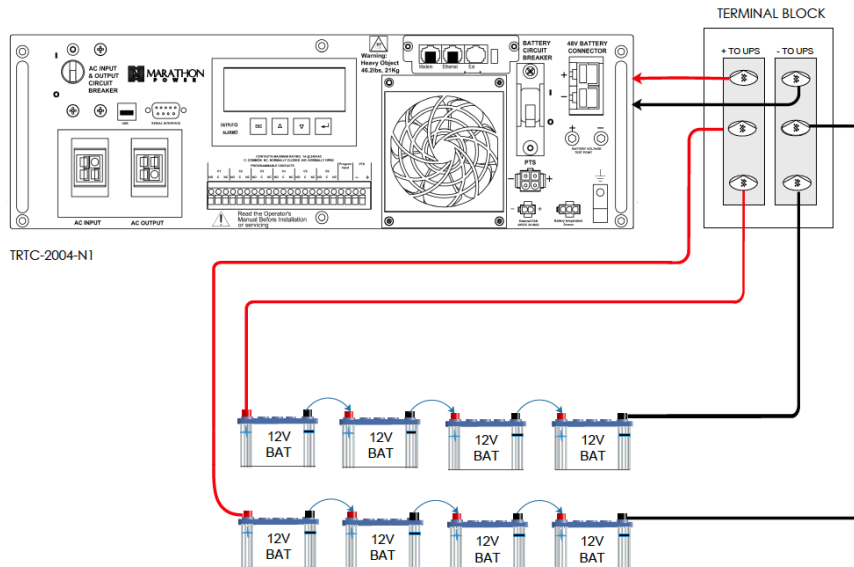

Green Control Terminal Block

The 22-position terminal block provides communication with the intersection controller, controls the Power Transfer Switch (PTS), and Programmable Input contact. The figure below shows its layout and operation.

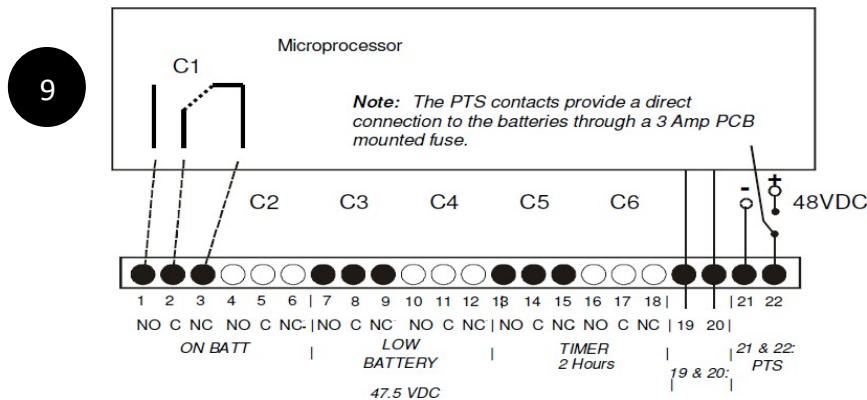

This terminal block is opto-isolated and shares a common ground with the serial interface. Each of the six programmable contacts can be programmed for one or more functions such as The Timer, Low Battery, and On Batt. The relay contacts are Form C type, i.e., each of the six programmable contacts has Common (C), Normally Closed (NC), and Normally Open (NO) contact position. These contacts have a maximum rating of 1 Amp at 120V. Only the first On Batt contact is illustrated. The remaining five contacts for Low Battery, Timer, etc., are similar.

- **On Batt:** This relay energizes when Utility Input line power is unqualified.
- **IMPORTANT:** When the AC input and output circuit breaker is turned OFF, an auxiliary switch of the circuit breaker opens, which disables the On Batt. contact at the Green Control Terminal Block. This prevents the intersection lights from flashing.
- **Low Battery:** These relays energize when the battery drops below the programmed battery capacity. The default value is 47.5VDC or 40% battery capacity.
- **Timer:** These relays energize after the unit has been in Battery Mode for the programmed time. The factory default value is 2 hours. The time can be programmed to be from 15 min. to 8 hours in 15-minute increments.
- **Program Input:** The programmable input contact can be programmed for one function such as Self-test, EXT Alarm, EXT Battery Alarm, EXT Fan Failure, Door Interlock. Jumper the TB 19 & 20 on the Green Control Terminal Block, and the program alarm will show on the LCD.
- **PTS:** TRTC UPS SERIES sends a 48VDC signal from the batteries to the PTS, which activates the PTS, resulting in transfer from Input power to BBS power. See Section 1.3, Wiring, of this manual for connection instructions.
- **Six sets of programmable contacts have the following factory default settings:** C1, C2 = "On Batt." C3, C4 = "Low Batt @ 47.5VDC" C5, C6 = "Timer @2.00 Hours"

Each of the six contacts are of the form C type, meaning Normally Open (NO), common (C) and Normally Closed (NC) dry contact rated for 1A @ 240VAC. These contacts can be individually programmed to energize and stay latched for ON BATTERY, LOW BATTERY, TIMER, ALARM, FAULT, and many other conditions described in subsequent chapters. The ON BATTERY contact(s) are activated as soon as the unit is transferred to Battery mode. LOW BATTERY contact(s) are activated only in the Battery mode as soon as the discharged battery reaches the lower value battery capacity as set by the user and remains latched as long as the system remains in Battery mode. The TIMER contact(s) are activated only in the Battery mode after the user-programmed time is attained. It can be set in 15-minute intervals from 15 minutes to 8 hours.

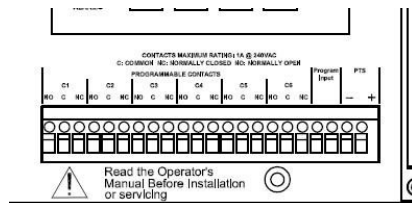

Torque status/self-test terminal block to a maximum of 4.4 lb.-in (0.5Nm).
Maximum wire size 14 AWG.

Connect the **COMMUNICATION CABLES** where appropriate. The USB port is not for USB communication. This port only allows serial RS232 communication, normally done using 9-pin serial cable, to be done using a more common, USB cable.

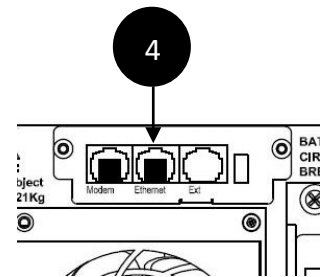
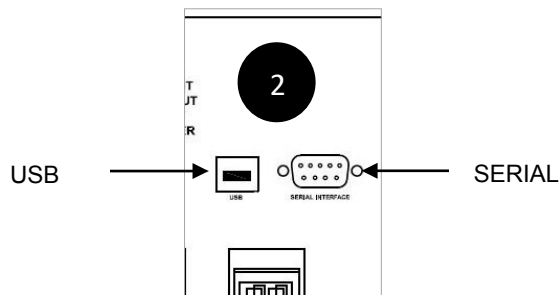

4.3 Starting Up the BBS

Purpose: Describes how to Start-up the system.

Step 1: Turn on the Utility Input Line Power

STARTUP PROCEDURE TIPS:

- The UPS automatically starts up in STANDBY mode.
- After the AC line is qualified (default 30 seconds) the UPS switches to ONLINE mode
- The PTS is fail safe in that the cabinet will always revert to utility power if there is ever a failure of the UPS or batteries.
- As an intersection safety measure, if there is no AC power and/or the AC breaker is not ON, the UPS will stay in STANDBY and can only be placed ON BATTERY manually to prevent accidentally leaving the intersection in operation on batter power without restoring AC power.

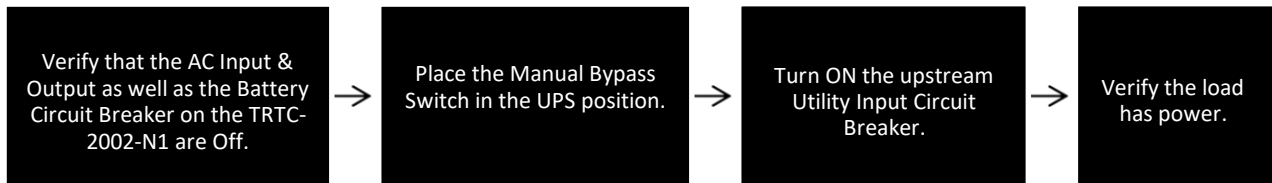

Step 2: Turn on the BBS

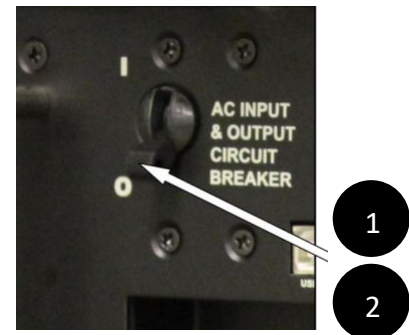
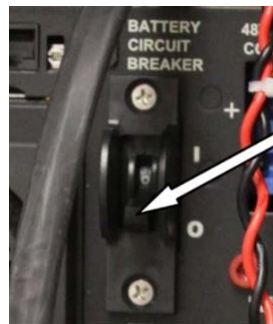
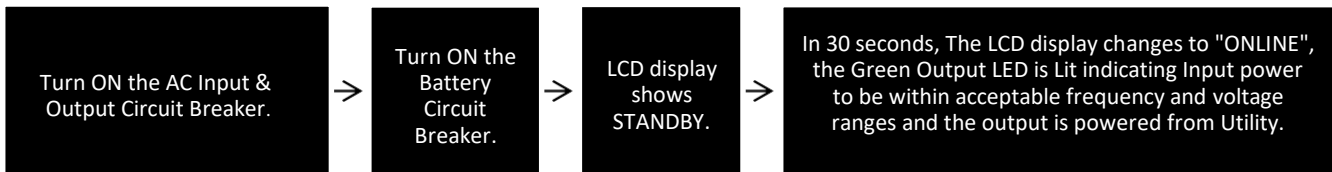

4.4 Testing the BBS

Before turning off the AC power to the intersection as a final test, verify proper installation and ability to go ON BATTERY by placing the MANUAL BYPASS SWITCH to BYPASS. The unit should immediately go ON BATTERY. When the MANUAL BYPASS SWITCH is returned to UPS, the unit should go back Online after AC Qualify time.



ATTENTION!

When performing the test below, if for any reason the unit fails to go ON BATTERY, immediately restore the AC power for the intersection at the upstream circuit breaker.

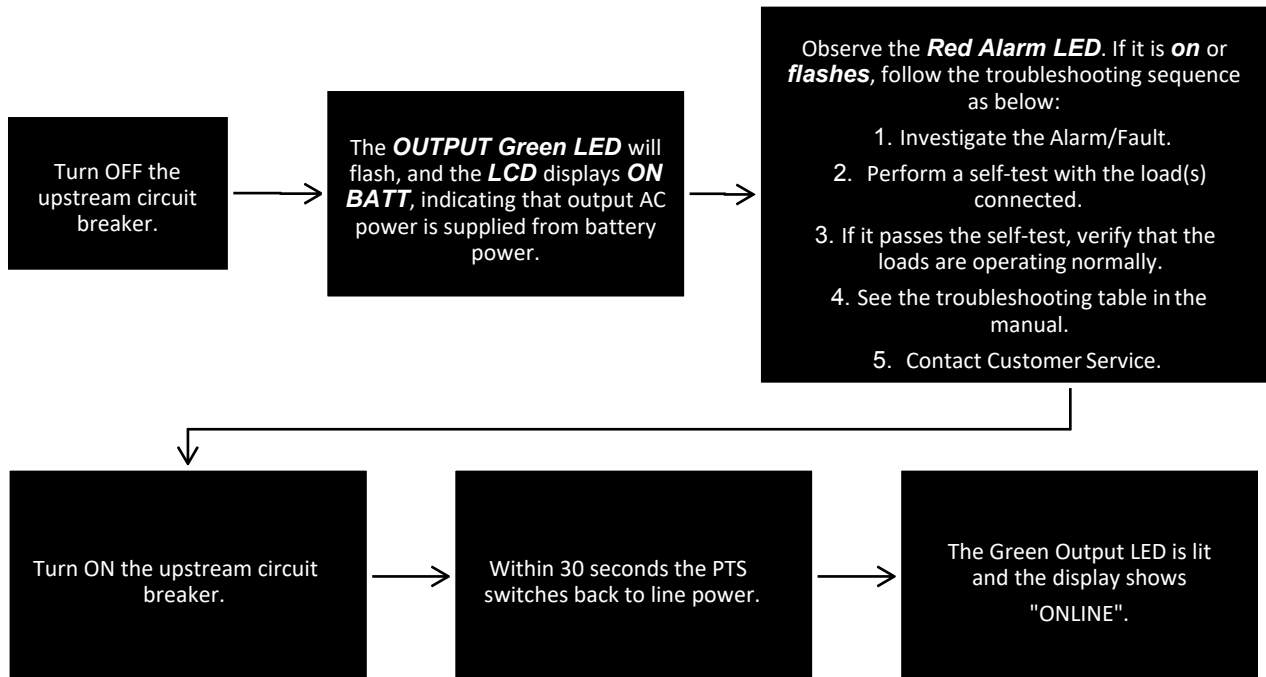

4.5 Shutting Down the BBS

Purpose: Describes how to shut down the system components for removal or maintenance.



ATTENTION!

Shutting down the TRTC-2004-N1 does not necessarily disconnect power to the loads.

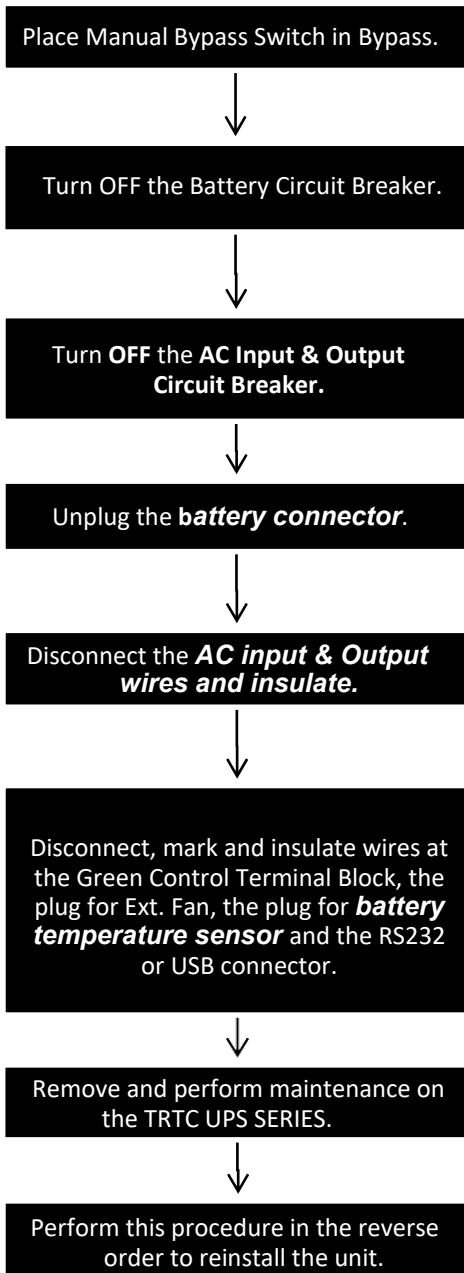

IMPORTANT: Place the Manual Bypass Switch in BYPASS before maintaining the unit or PTS to prevent accidentally losing power to the traffic signals.



DANGER!

The AC input wires from PTS are still **HOT** or **Live**.
Insulate the bare wires using wire nuts.

4.6 Emergency Shutdown

The TRTC-2004-N1 UPS is connected to more than one energy source. In an emergency, DISCONNECT utility input power, battery power, as well as an optional generator power, if utilized. Disconnecting all the AC and DC power sources will ensure that the output circuit is not live.

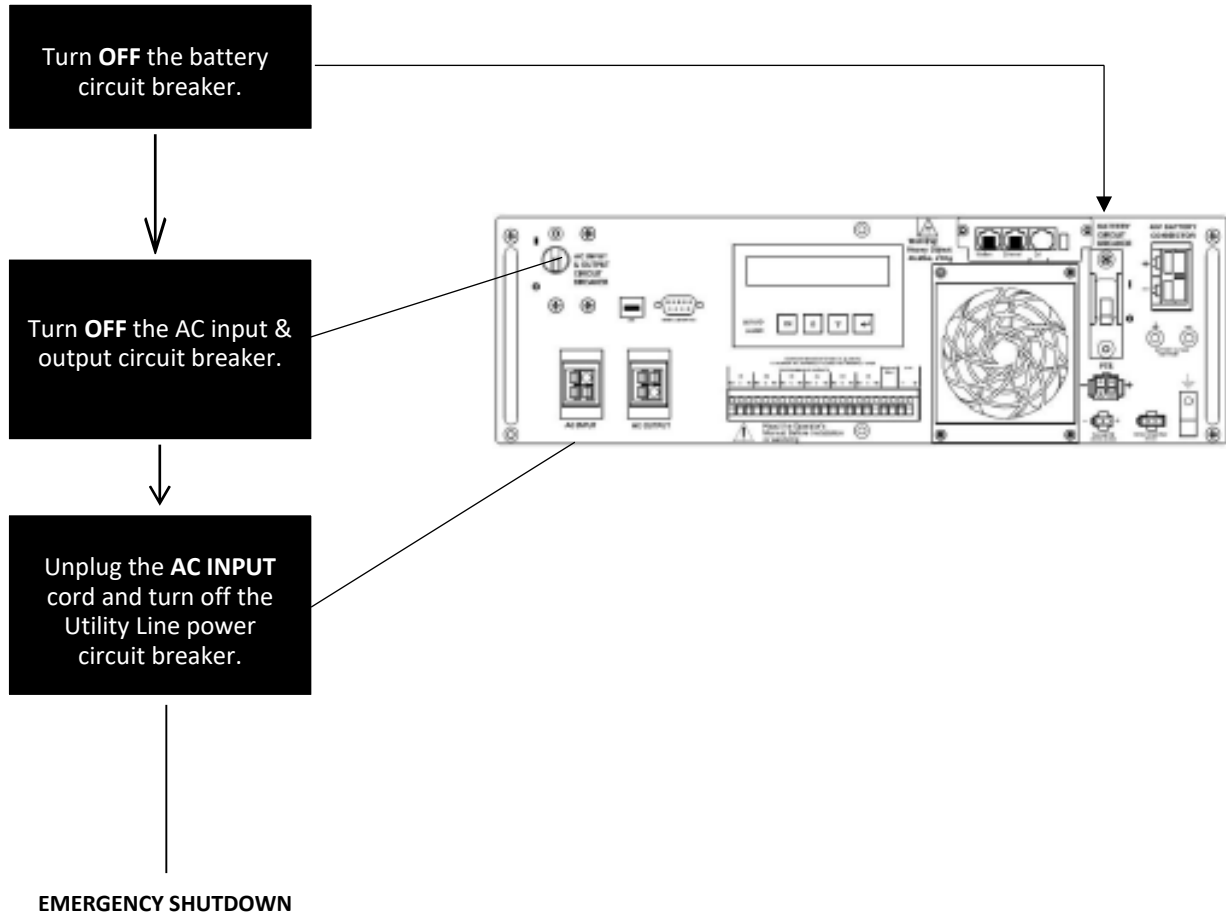

4.7 Removing the PTS

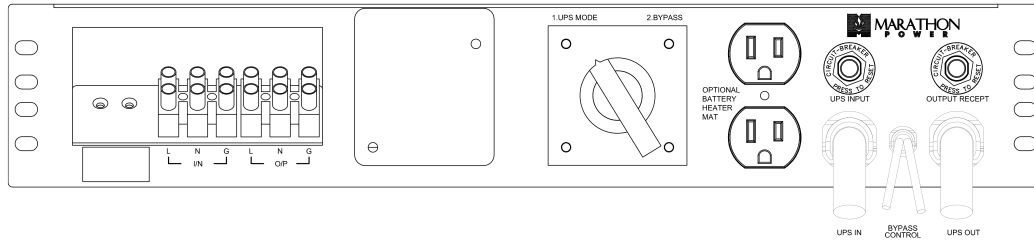

Turn OFF the Upstream Breaker.

Disconnect the UPS OUT Cord at the TRTC UPS SERIES.

Disconnect the UPS IN Cord at the TRTC-2004-N1.

Disconnect the Red & Black PTS control wires at the TRTC UPS SERIES.

Disconnect the wires from AC IN, NEUTRAL, GROUND and AC OUT from the PTS.

Remove and perform the maintenance on the PTS.

Perform this procedure in the reverse order to reinstall the PTS.

IMPORTANT: Verify that both the AC INPUT & OUTPUT and Battery Breaker are OFF at the TRTC UPS SERIES.

Place the Manual Bypass Switch in BYPASS before doing any maintenance on the unit or PTS to prevent accidentally losing power to the traffic signals.

4.8 Battery Back-up Test

It is recommended to perform this test every six months. Make sure the batteries are fully charged before starting this test.

EXAMPLE:

The start time is **1 PM**.
ON BAT contact, if selected, is activated.

Low Battery Alarm LED appears at **4 PM**.
LOW BAT contact at the selected value will be activated.

Low Battery capacity battery back-up time will be the time difference between 4 PM and 1 PM or **3 hours**.

Shutdown time is **5 PM**.
Battery reserve time will be the time difference between 4 PM and 5 PM or **1 hour**.

The **Total Battery back-up** time is the sum of Low Battery capacity back-up time and Battery Reserve time or the time difference between 5 PM and 1 PM or 4 hours.

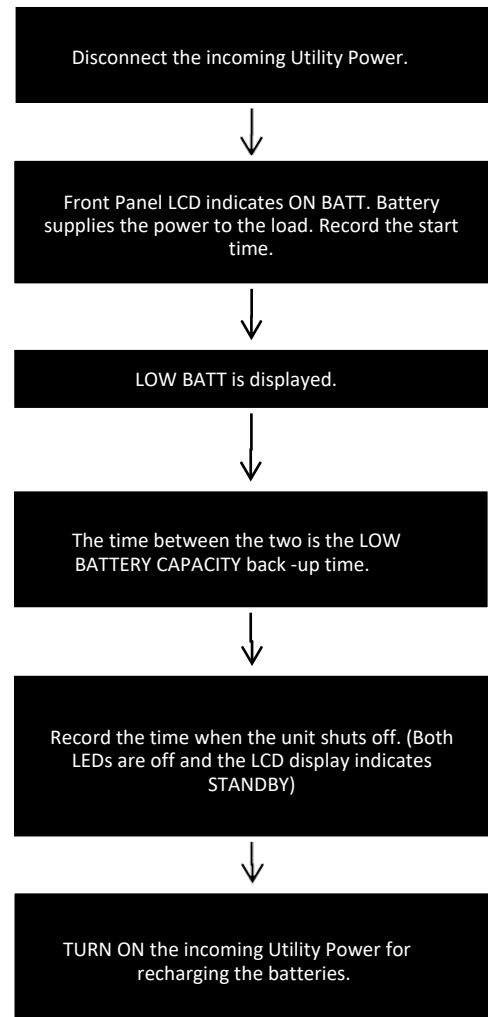

4.9 LCD Panel Key Functions

When the **Output LED** is:

- **ON**, the line is qualified, and the input power flows to output.
- **FLASHING**: The unit is in Battery mode.
- **OFF**, the output is OFF, a fault, the input line is not qualified, or the unit detected a fault.

If both LEDs are OFF and the LCD is **BLANK**, the unit is shutoff. When the **Fault LED** is:

- **ON**, the unit detected a **Fault**.

When the **Alarm LED** is:

- **ON**, the unit detected an **Alarm**.

Pushing the **ENTER** button displays the problem.

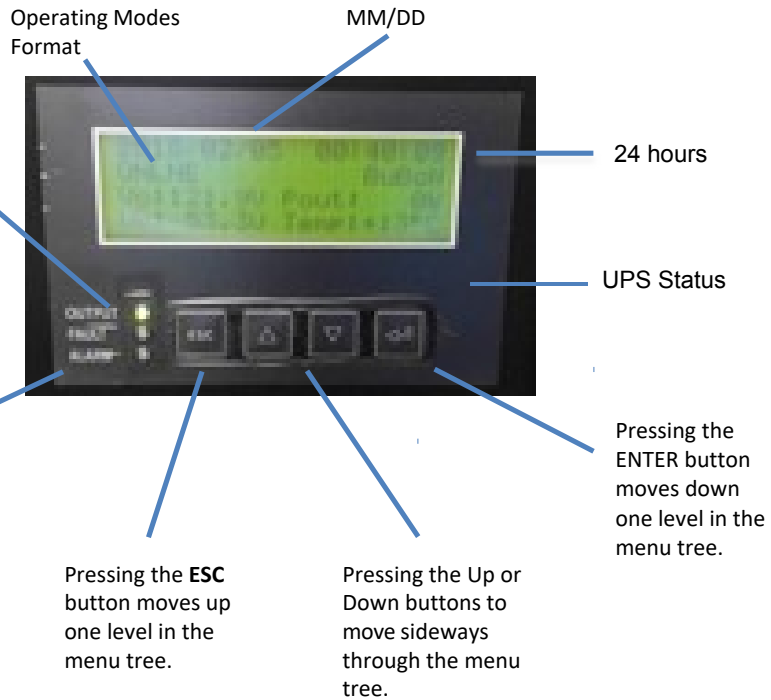

Note: When the ambient air temperature drops below -20°C (-4°F), the LCD may turn DARK until the temperature rises above -20°C (-4°F). However, the unit will operate normally.

For a detailed explanation of each of the LCD menus, see Section: 5 Operation – LCD Interface on page 42.

For a useful visual guide of the LCD Menus see Appendix 4 - TRTC-2004-N1 LCD Menu Tree on page 101.

CONTRAST ADJUSTMENT FOR LCD DISPLAY

1. To adjust the LCD contrast, press both the ESC and ENTER button at the same time.
2. Adjust the contrast using UP and DOWN arrows.
3. Press ENTER to save the adjustment.

Operating Modes

LCD Shows	<i>Explanation</i>
STANDBY	The UPS automatically starts up in STANDBY mode. After the AC line is qualified (default 30 seconds) the UPS switches to LINE mode as an intersection safety measure, if there is no AC power and/or the AC breaker is not ON, the UPS will stay in STANDBY and can only be placed ON BATTERY manually to prevent accidentally leaving the intersection in operation on battery power without restoring AC power.
ONLINE	The normal operating mode. Input line power is provided to the loads, the batteries are charging, and the UPS is ready to provide back-up power.
BOOST*	The unit automatically transfers to BOOST mode to raise the lower input line voltage when output drops below the user-programmable preset limit.
ON BATT	The unit automatically transfers to the battery when input line power is unqualified or not present. The batteries provide power to the loads.
BUCK	The unit automatically transfers to BUCK mode to reduce the higher input line voltage when output raises above the user-programmable preset limit.
SELF TEST	When the “Self-Test” mode is active, the unit will automatically enter “Battery Mode” to test or check if output voltage and waveform are correct. After the programmed duration, the unit returns to “Line Mode”. Users may use “Maintenance Mode” to configure a longer time for self-test. The default time for self-test is 1 minute.
LOW BATT	When the unit is in “Battery Mode” the batteries start to discharge. If the battery voltage falls below the user-programmed (40% default setting) of its capacity, a “Low Bat” warning appears.

* When enabled

Alarm Menu

Purpose: Describes the Alarm Submenu and how to use the LCD for troubleshooting.

Procedure: When the **Red ALARM LED** is **FLASHING**, the unit has an alarm, indicating a condition not severe enough to stop it from providing output power. Press **ENTER** to see the Alarm.

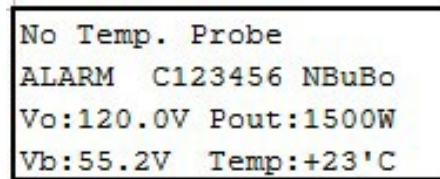
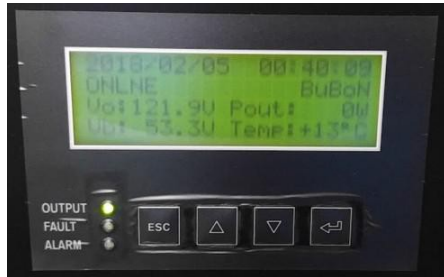

1. Red Alarm – LED FLASHING

2. The unit has ALARM condition

LCD SHOWS	Alarm	DESCRIPTION
Line Freq	Line Frequency	The Input frequency is fluctuating & out of tolerance.
Low O/P Volt	Low Output Voltage	The output voltage is low but still usable.
NO Temp. Probe	Temperature Probe Unplugged	The battery temperature probe is unplugged or damaged. When the unit detects the probe is unplugged, it will continue to operate, but the charger voltage will automatically be set to the lowest value.
Overload	Overload	The loads are drawing more power from the TRTC UPS SERIES than it can provide.
BATT not Conn	Battery Not Connect	The battery is not connected.
High Temp	High Temperature	The battery temperature is high.
Low Temp	Low Temperature	The Battery temperature is low.
Ext. Alarm	External Alarm	External Alarm - Programmable input contact.
Ext. Batt Alarm	External Battery Alarm	External battery Alarm - Programmable input contact.
Ext. Fan Fail	External Fan Fail	External Fan Failure - Programmable input contact.
Door Interlock	Door Interlock	Door interlock of the programable input contact.

Note: The alarms are self-resettable. After the alarm condition is removed, the unit automatically returns to Line mode if the line is qualified or battery mode if the line is unqualified.

Fault Menu

Purpose: Describes the Fault Submenu and how to use the LCD for troubleshooting.

Procedure: When the red **ALARM LED** is continuously ON, the unit has a fault, indicating a condition where back-up power is unavailable. Press **ENTER** to display fault description.

TIP: When the unit has a fault and line power is qualified and available, the output loads are directly connected to the Input line with no line conditioning or back-up power.

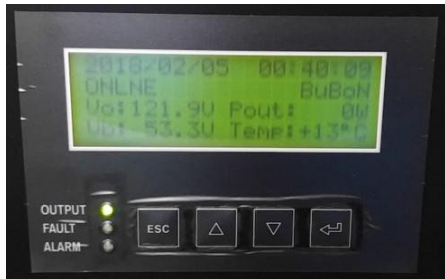

```
Short Circuit
Fault C123456 NBuBo
Vo: 0.0V Pout: 0W
Vb:55.2V Temp:+23°C
```

1. Fault LED on LED Shows a Fault

2. Unit has FAULT LCD Displays Fault

LCD SHOWS	Fault	DESCRIPTION
Short Circuit	Short Circuit	The load is short-circuited, or the inverter did not start.
Batt. Low Volt	Low Battery Voltage *	The battery's output voltage is low.
Batt. High Volt	High Battery Voltage *	The battery's output voltage is high.
Temp High	High temperature *	The battery temperature or the TRTC UPS SERIES internal temperature is high.
Overload	Overload	The loads are drawing more power than the TRTC UPS SERIES can provide.

* These faults are self-resetting. After the fault condition is removed, the unit automatically returns to Line mode if the line is qualified or Battery mode if not. The unit is reset for all other faults by shutting it down and restarting it using the AC and battery breakers. The faults can also be reset in the Control Menu of the LCD.

UPS Troubleshooting

SYMPTOM	CAUSE	REMEDY
No Output	AC input & output circuit breaker is OFF.	Turn input & output circuit breaker on.
	No incoming utility line power.	Apply incoming utility power by closing the upstream breaker.
	Red LED is lit solid on the front indicating FAULT.	Read the FAULT under the Status Menu of LCD. Clear the fault. Shut off both the breakers on the front panel, Restart. Contact Marathon Power if the fault persists.
Output LED OFF	Incoming utility power or battery power not available.	Apply qualified input power and verify battery breaker is closed.
	Faulty unit.	Contact factory.
The unit does not transfer to Battery mode during a power failure Or Back-up time is less than rated	The battery is not connected.	Connect batteries (48VDC nominal).
	Battery circuit breaker OFF.	Close battery breaker.
	The battery is not fully charged.	Fully recharge the battery, then test the back-up time.
	Dead battery.	Replace with a good battery.
	Battery failure.	Clean and tighten battery connections. Check batteries and replace them if needed.
	Faulty unit.	Contact vendor.
Alarm LED is lit	Red LED steady ON indicates FAULT.	Correct the Fault.
	Red LED flashing indicates ALARM.	Correct the Alarm. Contact the factory if the Alarm persists.
Batteries will NOT charge	Battery circuit OPEN.	Check that battery connections have proper torque. Check battery cable harness for connection error, loose/open connections. Check 46 to 53VDC present at the battery connector to TRTC UPS SERIES Check if the battery breaker is closed. Replace the bad battery, if any.
	Wrong or bad temperature probe connected at the front panel.	Use Factory supplied temperature probe reading approximately 12,000 OHMS @ 25°C (77°F).
LCD screen NOT readable	Adjust the contrast for the LCD screen.	Press and hold the ESC button. Press ENTER button. Adjust the contrast using UP or DOWN arrow Buttons. Press ENTER when completed.
	Faulty unit.	Contact factory.
Password Access NOT available	Entered Password is LOST or forgotten.	Call factory for resetting of the new password.

SYMPTOM	CAUSE	REMEDY
No Output available from PTS	Upstream utility circuit breaker or fuse may be OPEN.	Close the upstream utility breaker or fuse.
	Utility AC Power not available.	Check with the AC voltmeter & contact the Utility Company.
	Wiring error PTS terminal block.	Correct wiring at PTS.
	Faulty PTS.	If 120 VAC is present at “AC IN” and NEUTRAL at the PTS terminal block, replace the PTS.
PTS won't allow transfer to Battery mode	TRTC UPS SERIES output power not connected to PTS.	Verify that the “UPS OUT” cord from PTS is properly connected to the AC OUTPUT terminal block at the TRTC UPS SERIES.
	“UPS INPUT” circuit breaker at PTS is open.	Reset the breaker & clear the fault.
	Black and red control wires from PTS are not connected at the PTS connector on the TRTC UPS SERIES.	Check the connection at the TRTC UPS SERIES.
	48VDC signal missing at TB 21 and 22 of Green Control terminal block at the TRTC UPS SERIES.	Refer to Section 9.2 for further troubleshooting.
	Faulty PTS.	Replace PTS.
TRTC UPS SERIES does not return to input Line mode	Utility input line power is missing.	Verify that the “UPS IN” cord from PTS is properly connected to the AC INPUT Terminal Block at the TRTC UPS SERIES.
		Verify that the “UPS INPUT” circuit breaker at PTS is closed.
		Ensure that utility input is present.

PTS Troubleshooting

SYMPTOM	CAUSE	REMEDY
No Output available From PTS	Upstream utility circuit breaker or fuse may be OPEN.	Close the upstream utility breaker or fuse.
	Utility AC Power not available.	Check with the AC voltmeter & contact the Utility Company.
	Wiring error PTS terminal block.	Correct wiring at PTS.
	Faulty PTS.	If 120 VAC is present at "AC IN" and NEUTRAL at the PTS terminal block, replace the PTS.
PTS won't allow transfer to Battery mode	TRTC-2004-N1 output power not connected to PTS.	Verify that "UPS OUT" cord from PTS is properly connected to the AC OUTPUT terminal block at the TRTC-2004-N1.
	"UPS INPUT" circuit breaker at PTS is open.	Reset the breaker & clear the fault.
	Black and red control wires from PTS are not connected at the PTS connector on the TRTC-2004-N1.	Check the connection at the TRTC-2004-N1.
	48VDC signal missing at TB 21 and 22 of Green Control terminal block at the TRTC-2004-N1.	Refer to Section 9.2 for further troubleshooting.
	Faulty PTS.	Replace PTS.
TRTC-2004-N1 does not return back to input Line mode	Utility input line power is missing.	Verify that "UPS IN" cord from PTS is properly connected to the AC INPUT Terminal Block at the TRTC-2004-N1.
		Verify that the "UPS INPUT" circuit breaker at PTS is closed.
		Ensure that utility input is present.

Battery Care

This is intended only as general information for customers and end users of Marathon Power UPS product with lead-acid storage batteries.

Customers routinely have questions about the lifespan of batteries. There are several factors that all contribute to the useful life of the batteries used with the UPS:

1. The ambient temperature around the UPS.
2. How many times the batteries are discharged and recharged.
3. How well the batteries were stored and maintained, both prior to installation and during the life of the UPS.

The life span of the batteries is typically 3-5 years. Whether it's closer to 3 years or 5 years depends primarily on the factors above. For cooler operating environments, with fewer discharge/recharge cycles on well-maintained batteries, the life expectancy of a battery can approach up to 5 years. On the contrary, in the operating environments with extreme heat and moisture and numerous discharge/recharge cycles with poorly stored and maintained batteries the life of a battery can be reduced to two to three years.

If batteries are overly discharged or left standing in the discharged state for prolonged periods, hardened lead sulfate coats the electrodes and will not be removed during recharging. Such build up reduces the efficiency and life of the batteries and may permanently damage the battery. Also, over-charging can cause electrolyte to escape as corrosive gases. If a battery that has been damaged due to its internal chemistry as described above is used in a UPS, it can appear to the charging circuit as a "short circuit" causing excessive current to flow through the input and charger circuits and consequently destroying them.

- High & **dangerous voltages** are present inside the system. Only qualified personnel should perform installation and maintenance.
- Live battery wires **must not** touch the TRTC-2004-N1 chassis or any other metal objects. ***This can cause a fire or explosion.***
- **Inspect** the batteries once a year for signs of cracks, leaks, or swelling. Replace as needed.
- When batteries are in storage, **charge** them at least once every three months for optimum performance and to extend their lifetime.
- **Always** replace batteries with the ones of identical type and rating. **Never** install old or untested batteries. **Never** mix old with new batteries. **Never** mix the different amp hour rated batteries within one system.
- Use **insulated tools** during servicing.
- **Remove** all rings, watches, jewelry, or other conductive items before working inside the enclosure.
- **Follow** local regulations for the disposal of batteries. Recycling is the best method.
- **Never** burn batteries to dispose of them. ***They may explode.***
- Do not open the batteries. ***The contents are toxic.***

Alignment Procedure – Battery Backup Test

Purpose: Describes how to measure the back-up capacity of batteries.

This test provides the measurement of back-up time during power outage by actually discharging the batteries. The back-up time is load as well as battery dependent, thus more back-up time is available with a lower load (in Amps or Watts) and less time with more load.



TIP:

It is recommended to perform this test every 6 months. Make sure the batteries are fully charged before starting this test.

EXAMPLE:

Start time is **1PM**.

ON BAT contact if selected, is activated.

Low Battery Alarm LED appears at **4PM**.

LOW BAT contact at selected value will be activated.

Low Battery capacity battery back-up time will be the time difference between 4PM and 1PM or **3 hours**.

Shutdown time is **5PM**.

Battery reserve time will be the time difference between 4PM and 5PM or **1 hour**.

The **Total Battery Back-up** time is the sum of Low Battery capacity back-up time and Battery Reserve time or the time difference between 5PM and 1PM or 4 hours.

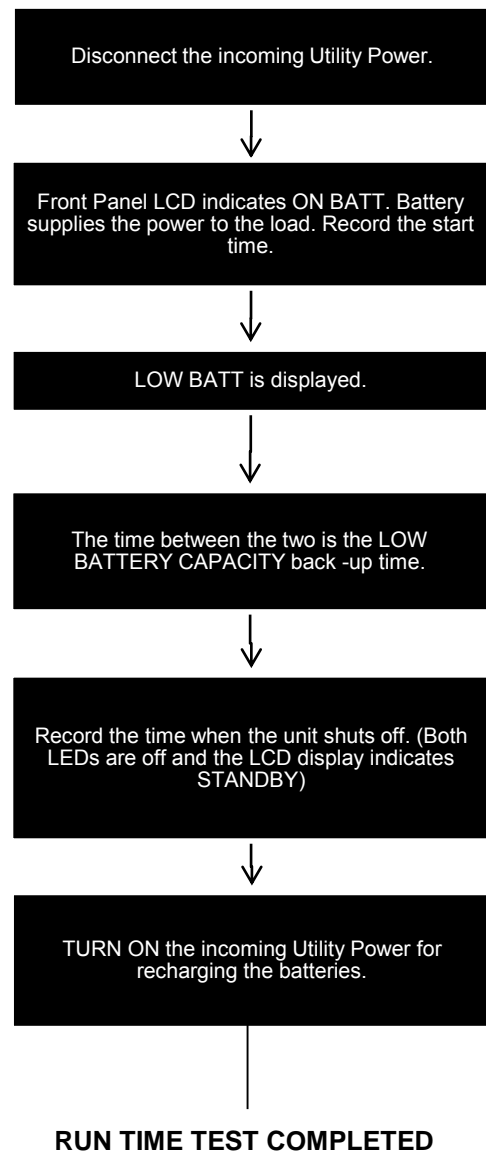

Section 5: Operation – LCD Interface

- ❖ 5.1 LCD Panel
- ❖ 5.2 Operating Modes
- ❖ 5.3 Main Screen and Menu Tree
- ❖ 5.4 Status Submenu
- ❖ 5.5 Control Submenu
- ❖ 5.6 Settings Menu
- ❖ 5.7 Maintenance Menu
- ❖ 5.8 Alarm Menu
- ❖ 5.9 Fault Menu
- ❖ 5.10 Event Log View
- ❖ 5.11 Low Battery Mode Status



Purpose: Describes the LCD display menus and use of user-friendly sub-menus.

LCD Panel Key Functions

When the **Output LED** is:

- **ON**, the line is qualified and the input power flows to output.
- **FLASHING**, the unit is in Battery mode.
- **OFF**, the output is OFF, a fault, input line is not qualified or the unit detected a fault.

If both LED's are OFF and the LCD is **BLANK**, the unit is shut off.

When the **Fault LED** is:

- **ON**, the unit detected a **Fault**.

When the **Alarm LED** is:

- **ON**, the unit detected an **Alarm**.

Pushing the **ENTER** button displays the problem.

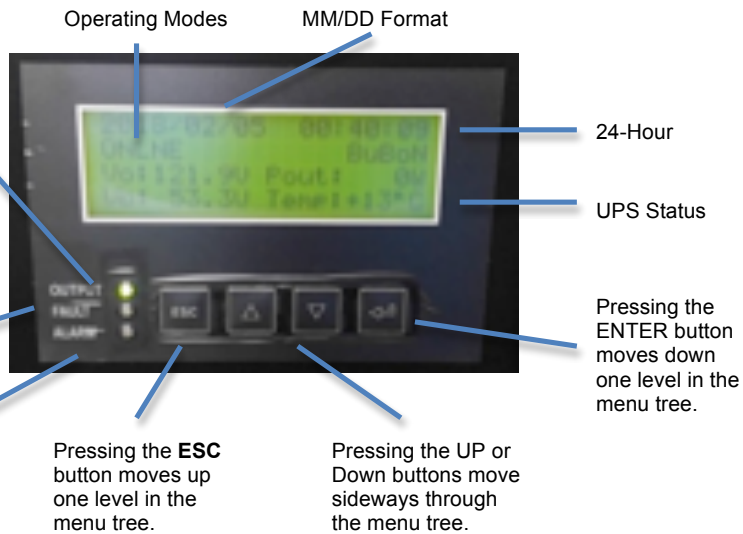

TIP: When the ambient air temperature drops below -20°C (-4°F), the LCD may turn DARK until the temperature rises above -20°C (-4°F). However the unit will operate normally.

CONTRAST ADJUSTMENT FOR LCD DISPLAY

1. To adjust the LCD contrast press both the ESC and ENTER button at the same time.
2. Adjust the contrast using UP and DOWN arrows.
3. Press ENTER to save the adjustment.

❖ 5.2 Operating Modes

Purpose: Describes the Operating modes.

TIP: The LCD automatically displays the following modes when they change.

LCD Shows	<i>Explanation</i>
STANDBY	This mode is displayed when the unit is first turned on. The inverter remains off and the UPS does not provide output power to the loads. If the input line power is qualified, it automatically switches to line mode. To provide battery power to the loads, use the manual on function.
ON LINE	The normal operating mode. Input line power is provided to the loads, the batteries are charging and the UPS is ready to provide backup power.
BOOST*	The unit automatically transfers to BOOST mode to raise the lower input line voltage when output drops below the user programmable preset limit.
ON BATT	The unit automatically transfers to battery when input line power is unqualified or not present. The batteries provide power to the loads.
BUCK	The unit automatically transfers to BUCK mode to reduce the higher input line voltage when output raises above the user programmable preset limit.
SELF TEST	When "Self Test" mode is active, the unit will enter "Battery Mode" automatically to test or check if output voltage and waveform is correct. After the programmed duration, the unit returns back to "Line Mode". Users may use "Maintenance Mode" to configure a longer time for self-test. Default time for self-test is 1 minute.
LOW BATT	When the unit is in "Battery Mode" the batteries begins to discharge. If the battery voltage falls below the user programmed (40% default setting) of its capacity, "Low Bat" warning appears.

* When enabled

❖ 5.3 Main Screen and Menu Tree

Purpose: Shows the Main Screen and Menu Tree.

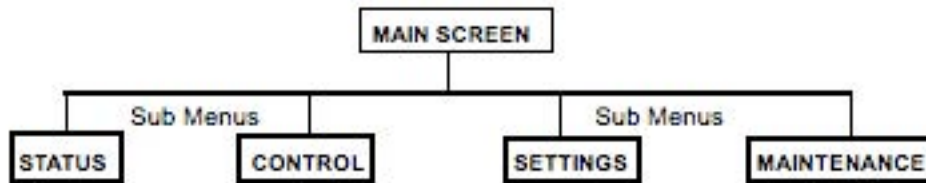

STATUS

01	V (in) = 120.0 VAC
	F (in) = 60.0 Hz
02	V (out) = 120.0 VAC
	P (out) = 1500 Watts
03	V (batt) = 55.2 VDC
	Battery Temperature = +27 °C
04	Inv. Event = 65536
	Inv. Timer = 0002.4H
05	Buck Event = 65536
	Buck Timer = 0002.4H
06	Boost Event = 65536
	Boost Timer = 0002.4H
07	C1=OFF C2=OFF C3=OFF
	C4= OFF C5= OFF C6=OFF
08	UPS Version = 4.0
	LCD Version = 4.0
09	IPA = 192.168.001.051
	MSK = 255.255.255.00
	GWY = 192.168.001.001
10	2)
	Self-Test
11	Program Contacts (See Table 3)
12	Line Conditioning (See Table 4)
13	Alarms (See Table 5)
14	Faults (See Table 6)

CONTROL

01	Self-Test
02	Program Contacts Test
03	Ext. Fan Test
04	Manual On / Reset
05	Events / Timer Reset
06	Log Reset
07	Password Protection

SETTINGS

01	Program Contacts (See Table 3)
02	AVR Feature (See Table 7)
03	Line Qualify (3Sec, 10Sec, 30Sec)
04	Ext. Fan Control (Turn On @ 20 ~ 50°C)
05	Sense Type (Normal / Generator Mode)
06	Batt. Temp. Comp. (-2.5mV~5mV/°C/Cell)
07	Set Date / Time
08	Daylight Saving
09	Program I/P Contacts (See Table 2)

MAINTENANCE

01	Batt. Test Option
02	Inverter On / Off
03	Event Log View
04	Line Conditioning (See Table 8)
05	Change Password

TABLES

TABLE 1 – UPS STATUS	
01	SFTST
02	BOOST
03	ONLINE
04	BUCK
05	LOBAT
06	ONBAT
07	STNBY
08	ALARM (See Table 5)
09	FAULT (See Table 6)

TABLE 2 – PROGRAM I / P CONTACTS	
01	Self-Test
02	EXT Alarm
03	EXT Battery Alarm
04	EXT Fan Failure
05	Door Interlock

TABLE 3 – PROGRAM CONTACTS	
01	ON BATT
02	LO BATT (42.0-55.0V / 0.5V increment)
03	TIMER (0.25-8hr / 0.25 increment)
04	ALARM
05	FAULT
06	DISABLE

TABLE 4 – LINE DETECTION	
01	Hi Lmt = 150 VAC
	Hi Hyst = 145 VAC
02	Hi Buck = 130 VAC
	Lo Buck = 125 VAC
03	Hi Boost = 107 VAC
	Lo Boost = 102 VAC
04	Lo Hyst = 095 VAC
	Lo Lmt = 090 VAC

TABLE 5 – ALARAM MESSAGE	
01	Line Freq.
02	Low O / P Volt
03	NO Temp. Probe
04	Over Load
05	BATT not Conn
06	High Temp.
07	Low Temp.
08	Ext. Alarm
09	Ext. Batt Alarm
10	Ext. Fan Fail
11	Door Interlock
12	Complex Alarm

TABLE 6 – FAULT MESSAGE	
01	Short Circuit
02	BATT Low Volt
03	BATT High Volt
04	High Temp.
05	Over Load
06	Complex Fault

TABLE 7 – AVR FEATURE	
01	Buck Feature
02	Boost Feature

TABLE 8 – ALARM MESSAGE	
01	Hi Lmt = 150 VAC
02	Hi Buck = 130 VAC
03	High gap = 005 VAC
04	Low gap = 005 VAC
05	Lo Boost = 102 VAC
06	Lo Lmt = 090 VAC

LCD Display & Control Instructions

LED Display:

There are 3 ea. LED indicators located next to the LCD Display, they display the following signals:

Red LED Glow	FAULT	Please refer to Faults Menu
Yellow LED Glow	ALARM	Please refer to Alarms Menu
Green LED Glow	On Line	UPS Output supplied by Utility power
Green LED Flashing	On Batt / AC Fail	Utility Power fails, UPS in Backup Battery Mode.

LCD Display & Control :

Note: The following symbols located at the right extreme of the LCD are the hints for pushbutton operation. Herein below the following symbols will be used to explain the LCD Display and Control: “↑” is UP arrow, “↓” is DOWN arrow, “⇕” is UP/DOWN arrow, “↵” is ENTER, “E” is ESC, which will be slightly different from the actual LCD Display.

Logo:

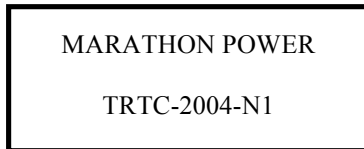

Following the start up of the BBS, this Logo screen will show up for 3 seconds. It includes company name and model name.

Main Screen:

```
2018/03/08 14:25:15
STATUS C123456FNBuBo
Vo:120.0V Pout:1500W
Vb:55.2V Temp:+23'C
```

After the logo screen, this screen will show up.

The first line show the date and time, Date is in yyyy/mm/dd format and can display from Year 2000 ~ Year 2099. The time is in 24 hours format. The second line shows UPS Status, Program contact status, Ext Fan status, Sense type and AVR feature. UPS Status includes: ON LINE, ON BATT, STANDBY, BOOST, BUCK, SELF TEST, LO BATT, LOW BATT S/D, ALARM and FAULT. Program Contact Status (C123456), when the contact number is shown, it means that the particular contact is activated (Closed). The third line shows Output Voltage and Output Power Watt. The fourth line shows Battery Voltage and Battery Temperature.

When alarm or fault presents, UPS Status will alternatively display the alarm (or fault) message and the aforementioned 8 different UPS status. And the fourth line will display the detail single alarm name or single fault name. If the display shows “See Status menu “. You need to inquire through the Status Menu.

```
No Temp. Probe
ALARM C123456FNBuBo
Vo:120.0V Pout:1500W
Vb:55.2V Temp:+23'C
```

```
See Status menu
ALARM C123456FNBuBo
Vo:120.0V Pout:1500W
Vb:55.2V Temp:+23'C
```

From the main screen, user can press ENTER to enter the main menu. Main menu allow you to make four choices: STATUS, CONTROL, SETTINGS, and MAINTENANCE, detailed as below:

```
M A I N M E N U [UP/DOWN]E
STATUS [DOWN]
UP/DOWN = Scroll
ENT = Open/Set
```

```
M A I N M E N U [DOWN]E
CONTROL [DOWN]
UP/DOWN = Scroll
ENT = Open/Set
```

```
M A I N M E N U [DOWN]E
SETTINGS [DOWN]
UP/DOWN = Scroll
ENT = Open/Set
```

```
M A I N M E N U [UP]E
MAINTENANCE [DOWN]
UP/DOWN = Scroll
ENT = Open/Set
```

At this time, you can press UP/DOWN button to select the Menu you want to execute. And then press ENTER to enter into that menu. When entering the MAINTENANCE menu, it is required to enter password.

```
Enter Password [UP/DOWN]E
Password : 1111 [DOWN]
UP/DOWN = CHANGE no.
ENT=CFM ESC=Return
```

STATUS Menu:

After entering into STATUS menu, you can press UP/DOWN to view UPS status information, including: Input Voltage - V(in), Input Frequency - F(in), Output Voltage - V(out), Output Power - P(out), Battery Voltage - V(batt), Battery Temperature - BATT. TEMP., Inverter Events - Inv. Event, Inverter Timer - Inv. Timer, Buck Events, Buck Timer, Boost Events, Boost Timer, Programmable Contact status C1 C2 C3 C4 C5 C6, Firmware Version Number - Version No., Network setup status, Programmable Input Contacts, Programmable Contacts, Transfer Points - Line Detection, Alarms - alarms, and Faults - faults. Their definitions and format are below:

```
S T A T U S      [E]
V (in) = 118.6 VAC
F (in) =  60.0 Hz
```

Format: xxx.x VAC

Format: xx.x Hz

```
S T A T U S      [E]
V (out)= 118.6 VAC
P (out)=   0  Watts
```

Format: xxx.x VAC

Format: xxxx Watts

```
S T A T U S      [E]
V (batt) = 55.6 VDC
Batt.Temp.= +21 'C
```

Format: xx.x VDC

Format: +xx °C. The UPS cannot sense the temperature of lower than -27 °C, therefore if temperature is below -27°C, it will display "Batt. Temp. < -27 °C". And if the Battery Temperature Probe is not connected, then it will display "Batt. Temp. = N/A".

```
S T A T U S      [E]
Inv.  Event =00012
Inv.  Timer =0000.0h
```

```
S T A T U S      [E]
BOOST Event =00000
BOOST Timer =0000.0h
```

```
S T A T U S      [E]
C1=OFF C2=OFF C3=OFF
C4=OFF C5=OFF C6=OFF
```

Format: xxxxx. Just display the Inverter Events counted. The maximum events can be displayed is 65535 ◦

Format: xxxx.xh. Maximum display value is 1092.2h. h = hours.



```
S T A T U S      [E]
UPS Version = 1.8
LCD Version = 4.0
```



Format: x.x



```
S T A T U S  E
IPA= 192.168.001.051
MSK= 255.255.255.000
GWY= 192.168.001.001
```



Format: IPA,MSK,GWY = XXX.XXX.XXX.XXX

```
S T A T U S  E
Program I/P Contact
Door Interlock
```

```
S T A T U S  E
Program Contacts 
```

```
S T A T U S  E
Line Conditioning 
```

```
S T A T U S  E
Alarms 
```

```
S T A T U S  E
Faults 
```

Among the Status, To view the: Program Contacts, or Line Detection, or Alarms, or Faults, and pressing the ENTER button will lead you into the sub-menu. Their functions are detailed below:

Program Contacts Menu:

```
S T A T U S  [E]
Program Contacts
C1 = ON BATT
C2 = ON BATT
```

```
S T A T U S  [E]
Program Contacts
C3 = LO BATT(47.5V)
C4 = LO BATT(47.5V)
```

```
S T A T U S  [E]
Program Contacts
C5 = TIMER(2.00hrs)
C6 = TIMER(2.00hrs)
```

Each of the programmable contacts C1 ~ C6 can be independently set up and its display will show the function that programmable contact was set. The programmable contacts can be set to reflect the following functionalities:

1. ON BATT (The contact will be activated when UPS is under Battery Mode.)
2. LO BATT (The settable Battery Voltage range is 42.0VDC~55.0VDC at 0.5VDC increment.)
3. TIMER (The settable timing range is 0.25hr~8hr at 0.25hr increment.)
4. ALARM (The display will directly show the alarm name, see "alarm menu" for details)
5. FAULT (The display will directly show the fault name, see "fault menu" for details)
6. DISABLE (The dry contact is disabled, the relay will not operate)

Note: When dry contact activates, the functionality description on the LCD Display of that particular contact will be flashing.

Line Detection Menu:

```
S T A T U S  [E]
Line Conditioning
Hi Lmt   = 150 VAC
Hi Hyst  = 145 VAC
```

```
S T A T U S  [E]
Line Conditioning
Hi Buck  = 130 VAC
Lo Buck  = 125 VAC
```

```
S T A T U S  [E]
Line Conditioning
Hi Boost = 107 VAC
Lo Boost = 102 VAC
```

```
S T A T U S  [E]
Line Conditioning
Lo Hyst  = 095 VAC
Lo Lmt   = 090 VAC
```

Format: xxx VAC

Hi Buck, Lo Buck, Hi Boost, Lo Boost can be enable or disable via SETTING menu.

Alarms Menu:

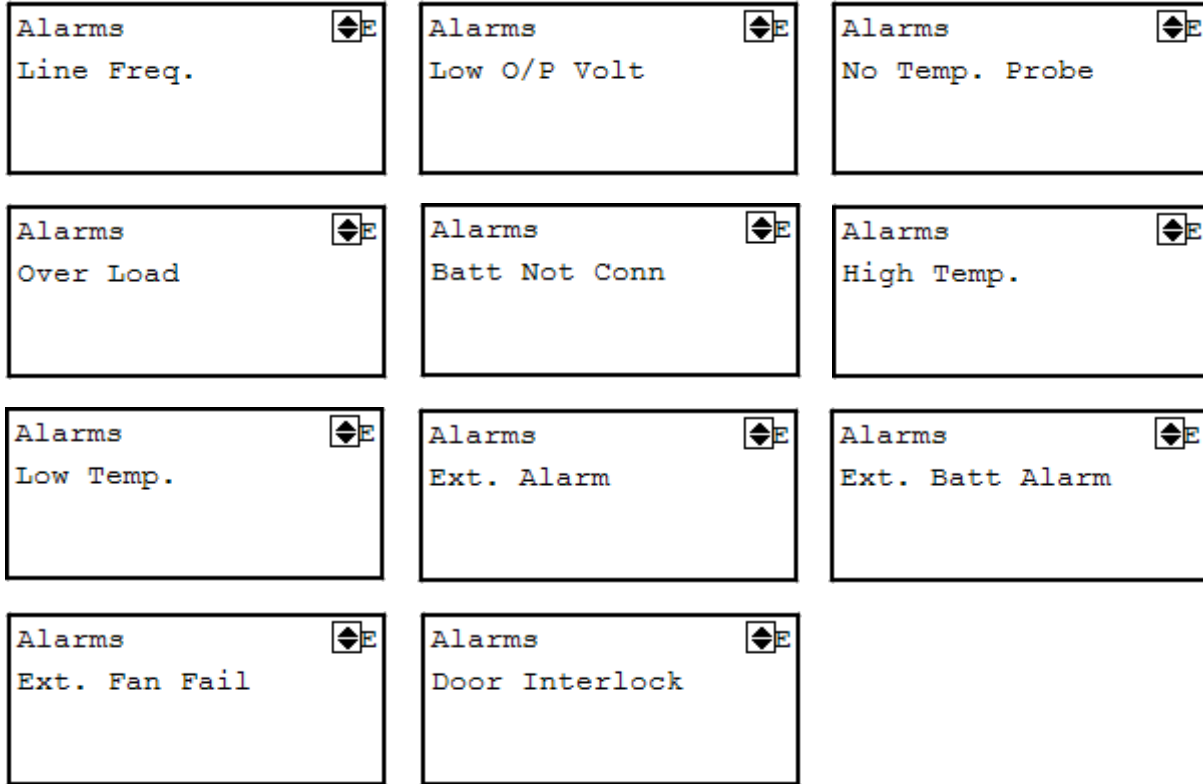

This alarm Menu covers all the alarm message listed below:

1. Line Freq.
2. Low O/P Volt
3. No Temp. Probe
4. Over Load
5. Batt Not Conn
6. High Temp.
7. Low Temp.
8. Ext. Alarm
9. Ext. Batt Alarm
10. Ext. Fan Fail
11. Door Interlock

When any two of the above listed alarm exist simultaneously, you can press UP/DOWN button to switch between the alarms. In the mean time, the display of arrow symbol will also follow and change. If none of the alarms exist, then it will display as below:

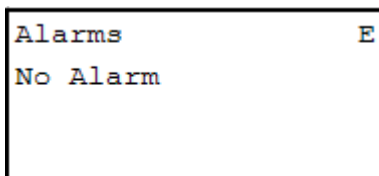

Faults Menu:

```
Faults      E
Short Circuit
```

```
Faults      E
Batt Low Volt
```

```
Faults      E
Batt High Volt
```

```
Faults      E
High Temp.
```

```
Faults      E
Over Load
```

This menu covers all the fault message listed below:

1. Short Circuit
2. Batt. Low Volt
3. Batt. High Volt
4. High Temp.
5. Over Load

When any two of the above listed alarm exist simultaneously, you can press UP/DOWN button to switch between the alarms. In the mean time, the display of arrow symbol will also follow and change. If none of the alarms exist, then it will display as below:

```
Faults      E
No Fault
```

CONTROL Menu:

After entering the CONTROL menu, you can press UP/DOWN button to select the UPS Control you wish to execute:

```
C O N T R O L  E
Self Test      ↓
ENT = Run
ESC = Return
```

At this point, you can press ENTER to activate the self test. After the execution of self test, The display will go back to main screen. Self test can only be activated when UPS under ON LINE, BUCK, BOOST status and UPS is not currently under ON Batt.

```
C O N T R O L  E
Pro. Contacts Test ↓
ENT = Entrance
ESC = Return
```

```
Pro. Contacts Test E
Contacts OFF      ↓
ENT = Enable/Disable
ESC = Return
```

```
Pro. Contacts Test E
Contacts ON      ↓
ENT = Enable/Disable
ESC = Return
```

You can press ENTER to activate the programmable contacts test. All contact will turn on in enable mode. And turn off in disable mode.

```
C O N T R O L  E
Ext. Fan Test    ↓
ENT = Entrance
ESC = Return
```

```
Ext. Fan Test E
Ext. Fan Off    ↓
ENT = Enable/Disable
ESC = Return
```

```
Ext. Fan Test E
Ext. Fan On    ↓
ENT = Enable/Disable
ESC = Return
```

You can press ENTER to activate the external fan test. External fan 48V will turn on in enable mode. And turn off in disable mode.

```
C O N T R O L  E
Manual On/Reset ↓
ENT = Manual On
ESC = Return
```

Press ENTER to execute Manual ON or Fault Reset function. Manual On can only be used when UPS is under STANDBY Mode. And Reset function can only be used when there is fault situation. After the execution, the display will go back to main screen.

```
C O N T R O L  E
Events/Timer Reset ↓
ENT = Reset All
ESC = Return
```

Press ENTER to clear the Inv. Events and Inv. Timer. After pressing the ENTER, the Inv. Events and Inv. Timer will be clear and reset to 0, and the display will go back to main screen. This function can only be executed when UPS is under ON LINE, BUCK, BOOST status.

```

C O N T R O L  [Up]E
Log Reset      [Down]
ENT = Reset All
ESC = Return

```

Press ENTER to clear the event log. After pressing ENTER, the content of Event Log will all be cleared, and the display will go back to main screen. This function can only be executed when UPS is under ON LINE, BUCK, BOOST status.

```

C O N T R O L  [Up]E
Pswrd Protection [Down]
ENT = Entrance
ESC = Return

```

```

Enter Password [Up]E
Password : 1111 [Down]
UP/DOWN = CHANGE no.
ENT = Confirm

```

```

Pswrd Protection [Up]E
Disable Password [Down]
UP or DOWN = CHANGE
ENT = Confirm

```

```

Pswrd Protection [Down]E
Enable Password  [Down]
UP or DOWN = CHANGE
ENT = Confirm

```

Press ENTER to set the password protection. After pressing ENTER, use the up or down keys to change password number. If the entered password is correct, the system will then allow you to enable or disable the “Password Protection”.

SETTINGS Menu:

After entering the SETTINGS menu, you can press UP/DOWN button to select the UPS function you wish to set, Detailed below:

```

S E T T I N G S  [E]
Program Contacts [E]
ENT = Entrance
UP or DOWN = Change
    
```

Press ENTER to enter the Programmable Contact setting menu, please follow the following operating procedures:

```

S E T T I N G S  [E]
Program Contacts [E]
ENT = Entrance
UP or DOWN = Change
    
```

⇓ Enter

```

S E T T I N G S  [E]
Program Contacts [E]
C1 = ON BATT [E]
    
```

⇕ Up/Down

```

S E T T I N G S  [E]
Program Contacts [E]
C2 = LO BATT(42.0V) [E]
    
```

⇕ Up/Down

```

S E T T I N G S  [E]
Program Contacts [E]
C3 = TIMER(0.25hrs) [E]
    
```

⇕ Up/Down

```

S E T T I N G S  [E]
Program Contacts [E]
C4 = No Temp. Probe [E]
    
```

⇕ Up/Down

```

S E T T I N G S  [E]
Program Contacts [E]
C5 = Short Circuit [E]
    
```

⇕ Up/Down

```

S E T T I N G S  [E]
Program Contacts [E]
C6 = DISABLE [E]
    
```

⇒ENTER
(for example)

```

S E T T I N G S
Program Contacts
C1 = ONBAT [E]
    
```

⇕ Up/Down

```

S E T T I N G S
Program Contacts
C1 = LOBAT [E]
42.0V [E]
    
```

⇕ Up/Down

```

S E T T I N G S
Program Contacts
C1 = TIMER [E]
0.25hrs [E]
    
```

⇕ Up/Down

```

S E T T I N G S
Program Contacts
C1 = ALARM [E]
Any Alarm [E]
    
```

⇕ Up/Down

```

S E T T I N G S
Program Contacts
C1 = FAULT [E]
Any Fault [E]
    
```

⇕ Up/Down

```

S E T T I N G S
Program Contacts
C1 = DISABLE [E]
    
```

1. After entering into Program Contacts menu, please use UP/DOWN button to select the contact need to be set, And press ENTER to enter the contact setting procedures.
2. After entering the contact setting procedures, the functionality display will be flashing, then you can press UP/DOWN to select that contact's functionality, such as: ON BATT, LO BATT, And etc.), and then Press ENTER to start detail setting process (only available for LO BATT, TIMER, ALARM and FAULT functionalities) °
3. After entering the process of setting the activation point, the display of the Setting value will be flashing. Press UP/DOWN button to select the setting value, press ENTER to confirm the setting value and complete the setting process.

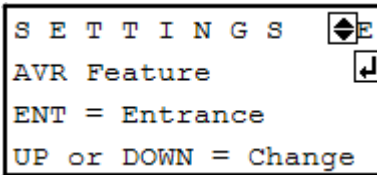

Press ENTER button to adjust the AVR Feature. The operating procedures are shown below:

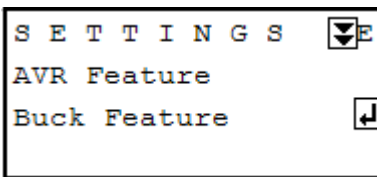

⇒ENTER

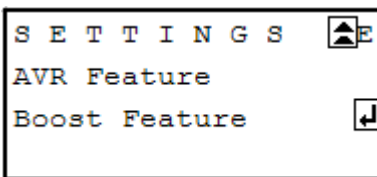
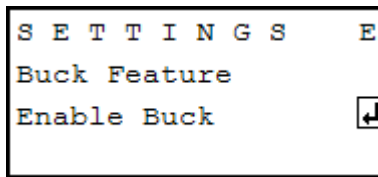
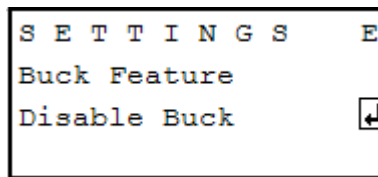

⇒ENTER

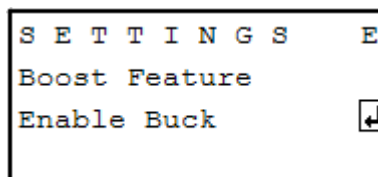
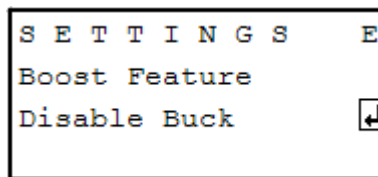

You can enable or disable the buck / boost function. Transfer point default settings are:
 Buck feature enable = Hi Lmt = 150 VAC , Hi Buck = 130 VAC
 Buck feature disable = Hi Lmt = 130 VAC , Hi Buck = disable
 Boost feature enable = Lo Lmt = 90 VAC , Lo Boost = 102 VAC
 Boost feature disable = Lo Lmt = 100 VAC , Lo Boost = disable

```
S E T T I N G S  [E]
Line Qualify      [E]
ENT = Entrance
UP or DOWN = Change
```

↓ ENTER

```
S E T T I N G S  [E]
Line Qualify      [E]
Set to 3 Sec.     [E]
UP/DOWN=CHNG ENT=CFM
```

```
S E T T I N G S  [E]
Line Qualify      [E]
Set to 10 Sec.    [E]
UP/DOWN=CHNG ENT=CFM
```

```
S E T T I N G S  [E]
Line Qualify      [E]
Set to 30 Sec.    [E]
UP/DOWN=CHNG ENT=CFM
```

Press ENTER button to adjust the line qualification timing. There are 3 different setting values for line qualification timing (3/10/30sec), use UP/DOWN button to select and press ENTER to confirm.

```
S E T T I N G S  [E]
Ext. Fan Control  [E]
ENT = Entrance
UP or DOWN = Change
```

```
S E T T I N G S  [E]
Ext. Fan Control  [E]
Turn On at 25 'C [E]
UP/DOWN=CHNG ENT=CFM
```

Press ENTER button to adjust the temperature fan that will turn ON. The settable range is 20°C ~ 55°C at 1°C increment. Use UP/DOWN button to select, and press ENTER to confirm.

```
S E T T I N G S  [E]
Sense Type        [E]
ENT = Entrance
UP or DOWN = Change
```

```
S E T T I N G S  [E]
Sense Type        [E]
Generator Mode    [E]
UP/DOWN=CHNG ENT=CFM
```

```
S E T T I N G S  [E]
Sense Type        [E]
Normal Mode       [E]
UP/DOWN=CHNG ENT=CFM
```

Press ENTER button to adjust the Sense Mode. This UPS can be set to Generator Mode or Normal Mode. Use UP/DOWN button to select, and press ENTER to confirm.

```
S E T T I N G S  [E]
Batt Temp. Comp. [E]
ENT = Entrance
UP or DOWN = Change
```

↓ ENTER

```
S E T T I N G S  [E]
Batt Temp. Comp. [E]
-2.5mV/'C/cell  [E]
UP/DOWN=CHNG ENT=CFM
```

```
S E T T I N G S  [E]
Batt Temp. Comp. [E]
-3.0mV/'C/cell  [E]
UP/DOWN=CHNG ENT=CFM
```

```
S E T T I N G S  [E]
Batt Temp. Comp. [E]
-4.0mV/'C/cell  [E]
UP/DOWN=CHNG ENT=CFM
```

```
S E T T I N G S  [E]
Batt Temp. Comp. [E]
-5.0mV/'C/cell  [E]
UP/DOWN=CHNG ENT=CFM
```

Press ENTER button to adjust the temperature compensation needed. There are 4 choices (-2.5/-3/-4/-5). Use UP/DOWN button to select and Press ENTER to confirm.

```
S E T T I N G S  [up/down]E
Set Date/Time    [down]
ENT = Entrance
UP or DOWN = Change
```

```
S E T T I N G S  E
Set Date/Time
09/15/2015 TU 16:28 [down]
UP/DOWN=CHNG ENT=CFM
```

Press ENTER button to adjust the date and time. You can see the current Date and Time, the display of the item to be set will be flashing. In sequence of Year, Month, Date, Hour, Minute, use UP/DOWN to adjust, then press ENTER to confirm. The format of Date is mm/dd/yy. The period can be displayed is from Year 2000 to Year 2099 (i.e., from 01/01/00 to 12/31/99). The time is in 24 hours format (i.e., hh:mm) °

```
S E T T I N G S  [up/down]E
Daylight Saving  [down]
ENT = Entrance
UP or DOWN = Change
```

```
S E T T I N G S  E
Enable DST ?
ENT:YES  ESC:NO
```

Press ENTER button to adjust the daylight saving setting. You can turn on and off daylight savings time to adjust the internal clock.

```
S E T T I N G S  [up/down]E
Program I/P Contact [down]
ENT = Entrance
UP or DOWN = Change
```

↓ ENTER

```
S E T T I N G S  [up/down]E
Program I/P Contact [up/down]
Self-Test          [down]
UP/DOWN=CHNG ENT=CFM
```

```
S E T T I N G S  [up/down]E
Program I/P Contact [up/down]
Ext. Alarm          [down]
UP/DOWN=CHNG ENT=CFM
```

```
S E T T I N G S  [up/down]E
Program I/P Contact [up/down]
Ext. BATT Alarm    [down]
UP/DOWN=CHNG ENT=CFM
```

```
S E T T I N G S  [up/down]E
Program I/P Contact [up/down]
Ext. FAN Alarm     [down]
UP/DOWN=CHNG ENT=CFM
```

```
S E T T I N G S  [up/down]E
Program I/P Contact [up/down]
Door Interlock     [down]
UP/DOWN=CHNG ENT=CFM
```

Press ENTER button to adjust the program input contact setting. There are 5 choices (Self-test / Ext. Alarm / Ext. BATT Alarm / Ext. FAN Alarm / Door Interlock). Use UP/ DOWN button to select and Press ENTER to confirm.

MAINTENANCE Menu:

Press ENTER to view the MAINTENANCE menu, then use UP/DOWN button to select the Functionality Menu, See below for details. When entering this menu, if the password protection setting in Control Menu is set as Enable Password, then you will need to enter password.

```

Enter Password  [E]
Password : 1111  [↓]
UP/DOWN = CHANGE no.
ENT = Confirm
    
```

↓ Password Correct
Go to MAINTENANCE
Sub-menu

⇒ Password Error

```

Enter Password  E
Password Error
UP/DOWN = CHANGE no.
ENT=CFM  ESC=Return
    
```

↓ ESC
Go to Main screen

```

MAINTENANCE  [E]
Batt Test Option  [↓]
ENT = Entrance
UP or DOWN = Change
    
```

```

MAINTENANCE  [E]
Batt Test Option
Period : 1 Min.  [↓]
UP/DOWN=CHNG ENT=CFM
    
```

Press ENTER to adjust the battery test timer. The settable time frame is from 1 minutes to 255 minutes with 1 minute increment. Use UP/DOWN button to select and press ENTER to confirm. This function can only be done when UPS is under ON LINE, BUCK, BOOST status.

```

MAINTENANCE  [E]
Inverter On/Off  [↓]
ENT = Run
UP or DOWN = Change
    
```

Press ENTER to directly control the Inverter ON/OFF. When alarm or fault present, or UPS is under ON LINE, BUCK, BOOST status, then this function can not be effectively performed. You can only perform this function when UPS is under ON BATT or STANDBY status.

```

MAINTENANCE  [E]
Event Log View  [↓]
ENT = Entrance
UP or DOWN = Change
    
```

```

MAINTENANCE  [E]
Event Log View
09/21/15  15:30
01100000  01010000
    
```

Press ENTER to view the Event Log. The first line shows the date (mm/dd/yy) and time (hh:mm) when the event occurs. The second line shows UPS situations: "1" means that situation present, "0" means such situation not exist. Press UP will switch to next event, Press DOWN will switch to the previous event.

0	1	2	3	4	5	6	7	8	9	10	11	12	13	14	15	16	17
0	1	1	0	0	0	0	0			0	1	0	1	0	0	0	0
AC High	AC Low	Black-out	Over Load	Hi Temp.	Batt Hi Volt	Batt Lo Volt	Short Circuit			Batt Low	Freq Low	Freq High	AC Fail	Reserved	Batt Hi Volt	No Temp. Probe	Batt Not Conn

```

MAINTENANCE [E]
Line Conditioning [↓]
ENT = Entrance
UP or DOWN = Change

```

Press ENTER button to adjust the UPS's Transfer points. The operating procedures are shown below:

```

MAINTENANCE [E]
Line Conditioning [↓]
ENT = Entrance
UP or DOWN = Change

```

⇒ENTER

```

MAINTENANCE [E]
Line Conditioning
Hi Lmt = 150 VAC [↓]
UP/DOWN=CHNG ENT=CFM

```

↓ Down

```

MAINTENANCE [E]
Line Conditioning
Hi Buck = 130 VAC [↓]
UP/DOWN=CHNG ENT=CFM

```

⇅ Up/Down

```

MAINTENANCE [E]
Line Conditioning
High_gap = 005 VAC [↓]
UP/DOWN=CHNG ENT=CFM

```

⇅ Up/Down

```

MAINTENANCE [E]
Line Conditioning
Low_gap = 005 VAC [↓]
UP/DOWN=CHNG ENT=CFM

```

⇅ Up/Down

```

MAINTENANCE [E]
Line Conditioning
Lo Boost = 102 VAC [↓]
UP/DOWN=CHNG ENT=CFM

```

⇅ Up/Down

```

MAINTENANCE [E]
Line Conditioning
Lo Lmt = 090 VAC [↓]
UP/DOWN=CHNG ENT=CFM

```

↑Up

1. After entering the Line Detection menu, use UP/DOWN button to select the Transfer point you wish to set, Press ENTER button and start Transfer Voltage setting procedures.
2. After entering the Transfer Voltage Setting procedures, the display of Voltage value will be flashing, and you can use UP/DOWN button to adjust the Transfer Voltage, and then press ENTER to confirm the setting voltage value and complete the setting of that Transfer point.
3. Hi Buck, Lo Buck, Hi Boost, Lo Boost can be set to disable or enable the transfer. If disabled, the UPS will not buck (or boost) to regulate the voltage.
4. The range of each transfer points are:

```

MAINTENANCE      E
Change Password  ↓
ENT = Entrance
UP or DOWN = Change
  
```

```

MAINTENANCE      E
Change Password
Password : 1111  ↓
UP/DOWN=CHNG ENT=CFM
  
```

Press ENTER button to change the default password. BE SURE TO RECORD THE NEW PASSWORD. The default password is 1111. This password setting or change function can only be successfully performed when UPS is under ON LINE, BUCK, BOOST status.













LCD MAIN SCREEN DETAILS





<i>ITEM</i>	<i>LCD SHOWS</i>	<i>DESCRIPTION</i>
Main screen	2018/03/08 14:25:15 SFTST C123456FNBuBo Vo:120.0V Pout:1500W Vb:55.2V Temp:+23'C	
Main screen Line 1	2018/03/08 14:25:15	Date & Timer
Main screen Line 2	SFTST C123456FNBuBo	Status Contact status C123456 Ext Fan status F Sense Type setting N: Normal , G: Generator AVR setting Bu: Buck , Bo: Boost
Main screen Line 3	Vo:120.0V Pout:1500W	The output voltage (ture RMS) The output Power (watts)
Main screen Line 4	Vb:55.2V Temp:+23'C	The average battery voltage The temperature of Battery case

❖ 5.4 Status Submenu

Purpose: Describes how to use the Status Submenu to measure the input and output parameters.

Procedure: When the desired item appears on the LCD screen, press ENTER to measure it. To see the updated reading press ENTER again.

ITEM	LCD SHOWS	DESCRIPTION
Page 1 Alarms	S T A T U S  E Alarms 	It indicates Alarms
Page 2 Faults	S T A T U S  E Faults 	It indicates Faults
Page 3 Input Voltage Input Frequency	S T A T U S  E V (in) = 118.6 VAC F (in) = 60.0 Hz	The Utility Input line voltage The Utility Input line frequency
Page 4 Output Voltage Output Power	S T A T U S  E V (out) = 118.6 VAC P (out) = 0 Watts	The output voltage (true RMS) The output Power (watts)
Page 3 Battery Voltage Battery Temperature	S T A T U S  E V (batt) = 55.6 VDC Batt.Temp. = +21 'C	The average battery voltage The temperature of Battery case
Page 4 Inv. Events Inv. Timer	S T A T U S  E Inv. Event = 00012 Inv. Timer = 0000.0h	The number of times the unit has been in Battery Mode The Total amount of time the unit has been in Battery Mode since the last reset. Each decimal indicates 6 minutes (0.1 x 6 minutes). The decimal increments by 2 or every 12 minutes.
Page 5 Buck Events Buck Timer	S T A T U S  E BUCK Event = 00000 BUCK Timer = 0000.0h	The number of times the unit has been in Buck Mode The Total amount of time the unit has been in Buck Mode since the last reset.
Page 6 Boost Events Boost Timer	S T A T U S  E BOOST Event = 00000 BOOST Timer = 0000.0h	The number of times the unit has been in Boost Mode The Total amount of time the unit has been in Boost Mode since the last reset.
Page 7 Program Contact C1~C6 status	S T A T U S  E C1=OFF C2=OFF C3=OFF C4=OFF C5=OFF C6=OFF	The status of the program contact C1,C2,C3.C4.C5.C6
Page 8 UPS Firmware version LCD Firmware version	S T A T U S  E UPS Version = 4.0 LCD Version = 4.1	The software version used in this unit. 4.0⇒Control board 4.0⇒LCD Board















Page 9 Network settings	S T A T U S  E IPA= 192.168.001.051 MSK= 255.255.255.000 GWY= 192.168.001.001	The network setting for Network card.
Page 10 Program Input Contact	S T A T U S  E Program I/P Contact Door Interlock	It indicates Programmed values of Input Contact
Page 11 Program contact	S T A T U S  E Program Contacts	It indicates Programmed values of all 6 Contacts
Page 12 Line Conditioning	S T A T U S  E Line Conditioning	It indicates Programmed values of all input Line Detection parameter & warning levels

❖ 5.5 Control Submenu

Purpose: Describes how to use the control submenu to operate the unit.

Procedure: When the desired function appears on the LCD screen, pressing the **ENTER** button calls it up.

Many functions have more than one option available. Scroll through them by pressing the toggle buttons. When the desired option appears, pressing the ENTER button switches the unit to the new option.



















FUNCTION	LCD SHOWS	ACTION
SELF TEST	C O N T R O L  Self Test  ENT = Run ESC = Return	Pressing ENTER starts the self test CAUTION: The unit must be in Line Mode before starting the self-test.
PROGRAM CONTACTS TEST	C O N T R O L  Pro. Contacts Test  ENT = Entrance ESC = Return	Pressing ENTER starts the program contact switch test.
EXTERNAL FAN TEST	C O N T R O L  Ext. Fan Test  ENT = Entrance ESC = Return	Pressing ENTER starts the external fan switch test.
MANUAL ON/RESET	C O N T R O L  Manual On/Reset  ENT = Manual On ESC = Return	This function is available only when the unit is first turned on the LCD shows Standby. Pressing ENTER manually starts the unit and the Battery supplies the output power.
EVENTS/TIMER RESET	C O N T R O L  Events/Timer Reset  ENT = Reset All ESC = Return	Press ENTER when the LCD displays the message. This resets the event and timer counters to zero.
LOG RESET	C O N T R O L  Log Reset  ENT = Reset All ESC = Return	Press ENTER when the LCD displays the message. This clears all the messages from the Event Log.
PASSWORD PROTECTION	C O N T R O L  Pswrd Protection  ENT = Entrance ESC = Return	This feature allows user to control the access of the Maintenance Menu with or without the password. When the Password access to the Maintenance Menu is Enabled here, the Maintenance Menu can ONLY be accessed when the correct Password is entered. When the Password access to the Maintenance Menu is DISABLED here, the Maintenance Menu can be accessed without the Password.

❖ 5.6 Settings Menu

Purpose: Describes how to access and program various critical parameters.

Procedure: When the desired function appears on the LCD screen, pressing the **ENTER** button calls it up.













Many functions have more than one option available. Scroll through them by pressing the toggle buttons. When the desired option appears, pressing the **ENTER** button switches the unit to the new option.

FUNCTION	LCD SHOWS	ACTION
PROGRAM CONTACTS	S E T T I N G S  Program Contacts  ENT = Entrance UP or DOWN = Change	Indicates programmed values of all 6 contacts and allows values to be changed.
AVR FEATURE	S E T T I N G S  AVR Feature  ENT = Entrance UP or DOWN = Change	Enable and Disable Buck and Boost function.
LINE QUALITY	S E T T I N G S  Line Qualify  ENT = Entrance UP or DOWN = Change	Indicates the setting for AC recovery time. The selection options are: 3 sec, 10 sec, or 30 sec. Default recovery time is 30 sec.
EXTERNAL FAN CONTROL	S E T T I N G S  Ext. Fan Control  ENT = Entrance UP or DOWN = Change	Indicates temperature setting for external fan.
SENSE TYPE	S E T T I N G S  Sense Type  ENT = Entrance UP or DOWN = Change	Toggle between Generator [Generator parameter] and Normal [Normal parameters]. This broadens the unit's input parameters to accommodate the fluctuations created by a generator or noisy line
BATTERY TEMPERATUER COMPENSATED	S E T T I N G S  Batt Temp. Comp.  ENT = Entrance UP or DOWN = Change	This adjusts the battery charging temperature compensated voltage to -3 / -4 / or -5 mV/°C/Cell. Consult the manufacture's specifications to find out which setting is best suited for your batteries. The factory default setting is -3 mV/°C /Cell.
SET DATE/TIME	S E T T I N G S  Set Date/Time  ENT = Entrance UP or DOWN = Change	It indicates setting for date and time.
DAYLIGHT SAVING	S E T T I N G S  Daylight Saving  ENT = Entrance UP or DOWN = Change	Enable and Disable daylight saving function.
PROGRAM INPUT CONTACT	S E T T I N G S  Program I/P Contact  ENT = Entrance UP or DOWN = Change	Indicates programmed value of input contact and allow value to be changed.

❖ 5.7 Maintenance Menu

Purpose: Describes how to access, and view and modify various parameters for the maintenance.

ONLY trained and qualified personnel normally use this menu, consequently the password protection option is provided to access this Menu.

FUNCTION	LCD SHOWS	ACTION
PASSWORD ACCESS	Enter Password  Password : 1111  UP/DOWN = CHANGE no. ENT = Confirm	If a Password access is Enabled in CONTROL Menu, than it must be entered here before the Maintenance Menu can be accessed. Use the UP / DOWN arrow key with ENTER keys to enter a correct Password. Reentry is required if an error is made entering a Password.
BATTERY TEST OPTION	MAINTENANCE  Batt Test Option  ENT = Entrance UP or DOWN = Change	Battery Test Option can be verified here. Battery Test period of 1 to 255 minutes can be selected here in 1 minute increments. The TRTC-2004-N1 can be tested to run on Battery for Maintenance purposes here.
INVERTER ON/OFF	MAINTENANCE  Inverter On/Off  ENT = Run UP or DOWN = Change	Inverter can be turned ON or OFF. This option is available ONLY when the TRTC-2004-N1 is in Battery or Standby Mode.
EVENT LOG VIEW	MAINTENANCE  Event Log View  ENT = Entrance UP or DOWN = Change	The Event Log with Date & Time is viewed here in Binary digital format.
LINE CONDITIONING	MAINTENANCE  Line Conditioning  ENT = Entrance UP or DOWN = Change	Indicates programmed values of all input Line Detection parameters & warning levels and allows values to be changed.
CHANGE PASSWORD	MAINTENANCE  Change Password  ENT = Entrance UP or DOWN = Change	The Password for the access of the Maintenance Menu is changed here. Use the UP / DOWN arrow key with ENTER keys to enter a correct Password. Reentry is required if an error is made entering a Password.

❖ 5.8 Alarm Menu

Purpose: Describes the Alarm Submenu and how to use the LCD for troubleshooting.

Procedure: When the **Red ALARM LED** is **FLASHING**, the unit has an alarm, indicating a condition not serious enough to stop it from providing output power. Press **ENTER** to see the alarm.



1. Red Alarm – LED FLASHING

```
No Temp. Probe
ALARM C123456 NBuBo
Vo:120.0V Pout:1500W
Vb:55.2V Temp:+23°C
```

2. Unit has ALARM condition

LCD SHOWS	Alarm	DESCRIPTION
Line Freq	Line Frequency	The Input frequency is fluctuating & out of tolerance.
Low O/P Volt	Low Output Voltage	The output voltage is low, but still usable.
NO Temp. Probe	Temperature Probe Unplugged	The battery temperature probe is unplugged or damaged. When the unit detects the probe is unplugged, it will continue to operate but the charger voltage will automatically be set to the lowest value.
Over Load	Overload	The loads are drawing more power from the TRTC-2004-N1 than it can provide.
BATT not Conn	Battery Not Connect	The Battery is not connected.
High Temp	High Temperature	The Battery temperature is high.
Low Temp	Low Temperature	The Battery temperature is low.
Ext. Alarm	External Alarm	The external alarm of the program input contact.
Ext. Batt Alarm	External Battery Alarm	The external battery alarm of the program input contact.
Ext. Fan Fail	External Fan Fail	The external fan fail of the program input contact.
Door Interlock	Door Interlock	The door interlock of the program input contact.

Note: The alarms are self-resettable. After the alarm condition is removed, the unit automatically returns to Line mode if the line is qualified, or battery mode if the line is unqualified.

❖ 5.9 Fault Menu

Purpose: Describes the Fault Submenu and how to use the LCD for troubleshooting.

Procedure: When the red **ALARM LED** is continuously ON, the unit has a fault, indicating a condition where backup power is unavailable. Press **ENTER** to display fault description.

TIP: When the unit has a fault and line power is qualified and available, the output loads are directly connected to the Input line with no line conditioning or backup power provided.



1. Fault LED on
LED Shows a Fault

```
Short Circuit
Fault C123456 NBuBo
Vo: 0.0V Pout: 0W
Vb:55.2V Temp:+23°C
```

2. Unit has FAULT
LCD Displays Fault

LCD SHOWS	Fault	DESCRIPTION
Short Circuit	Short Circuit	The load is short-circuited or the inverter did not start.
Batt. Low Volt	Low Battery Voltage *	The batteries output voltage is low.
Batt. High Volt	High Battery Voltage *	The batteries output voltage is high.
Temp High	High Temperature *	The battery temperature or the TRTC-2004-N1 internal temperature is high.
Over Load	Overload	The loads are drawing more power than the TRTC-2004-N1 can provide.

* These faults are self-resetting. After the fault condition is removed, the unit automatically returns to Line mode if the line is qualified or Battery mode if not. For all other faults, the unit is reset by shutting it down and restarting it using the AC and battery breakers. The faults can also be reset in the Control Menu of the LCD display.

❖ 5.10 Event Log View

Purpose: Describes how to view and interpret the Event Log or Alarm Log.

Procedure: In the LCD panel, scroll down to the Maintenance Menu. Enter the password, using up / down arrows, to access the Maintenance Menu. The password is required only when the access to this menu is password protected in the control menu. The factory default password is 1111. Consult the factory if the programmed password is lost or forgotten. The last item in the Maintenance Menu is the EVENT LOG VIEW. The LCD screen displays the information in digital binary form. The full descriptive details can be seen using your PC in RS232 / USB mode.

ALARM IS DISPLAYED IN THE DIGITAL BINARY FORM

Two blocks of numbers appear on the second line of the LCD screen. Each block has 8 digits, for a total of 16 digits. The position of each one of the 16 digits indicates a unique event. A value of 1 indicates the presence of an event represented by the position of that digit, while a value of 0 indicates an absence of that event. The assignment of events for each of these 16 digits is identified below.

Example

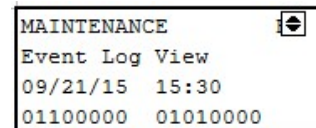
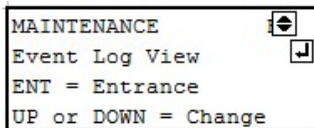

Position 1 ----- 12345678
1st Block of 8 digits

12345678 ----- Position 16
2nd Block of 8 digits

At the Event Log view menu press ENTER to access the Event Log View function. The first line indicates the date (MM/DD/YY) and time (HH:MM) of the event occurrence. The second line shows Events in UPS. Pressing UP allows to the next event, pressing DOWN allows to view the previous event.

1st Block of 8 Digits:

1	2	3	4	5	6	7	8
AC High	AC Low	Black-Out	Over Load	Hi Temp	Battery High Voltage	Battery Low Voltage	Short Circuit

2nd Block of 8 Digits:

9	10	11	12	13	14	15	16
Battery Low	Freq Low	Freq High	AC Fail	External Alarm	Battery Temp Over-Range	No Temp. Probe	Battery Not Connect

❖ 5.11 Stages of Battery Mode

Purpose: Describes the various states of the Low Battery Mode.

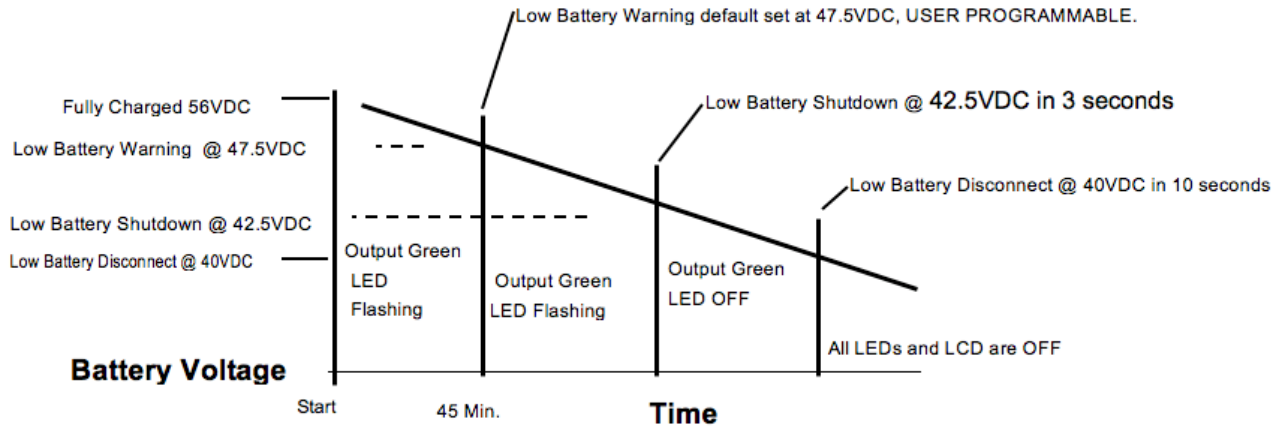

Note: Not to scale. All values are shown for illustrative purpose *only* and will **change under different operating and battery conditions**. Actual times will be different. Perform a run time test (Section 2.4.1) for application specific operating conditions.

Low Battery Warning

The batteries will continue to power the load, but they are almost discharged and cannot provide power much longer.

TIP: The operator should shut down unnecessary loads to extend battery backup time.

Low Battery Shutdown

When the battery decreases to 42.5VDC for 3 seconds, the unit automatically shuts output OFF and goes into SLEEP mode waiting for input power to return. The batteries are considered fully discharged and can no longer support the load, but they have enough power to keep the unit's monitoring and control circuits active. The housekeeping power supply is kept alive.

Low Battery Disconnect

When the battery discharges to 40VDC for 10 seconds, the unit automatically goes into this mode. The batteries are disconnected from the unit to protect the batteries from being damaged by a deep discharge. Both the LED and LCD shut OFF, showing the unit is shut off. The unit stays off until line power or a backup generator is available or fresh batteries are connected. To prevent battery damage, if the TRTC-2004-N1 is to remain in a low battery disconnect state for an extended period. The TRTC-2004-N1 and battery circuit breakers **must be** switched OFF and the manual bypass switch **must be** switched to the Bypass position. For additional protection disconnect the Anderson style battery connector from the TRTC-2004-N1.



Note: only authorized personnel should perform all parameter changes, as it may affect the performance of the traffic intersection.

Section 6: Operation – RS-232 / USB Interface

- ❖ 6.1 RS-232 / USB Interface Info
 - ❖ 6.2 Putty Settings
 - ❖ 6.3 HyperTerminal Settings
 - ❖ 6.4 Menu Tree
 - ❖ 6.5 Main Menu
 - ❖ 6.6 Submenus
 - ❖ 6.7 Unit Specifications
 - ❖ 6.8 Input / Output Values
 - ❖ 6.9 Maintenance
 - ❖ 6.10 Transfer Point Parameters
 - ❖ 6.11 Transfer Point Descriptions
-



❖ 6.1 RS-232 / USB Interface Info

The TRTC-2004-N1 has both RS-232 and USB ports built in for serial communication. Using either requires a graphical user interface. Microsoft stopped including HyperTerminal with their operating system.

Two alternatives we recommend are:

1. PuTTY (<http://en.wikipedia.org/wiki/PuTTY>) and is available for download at <http://www.chiark.greenend.org.uk/~sgtatham/putty/download.html>
2. HyperTerminal available at <http://www.hilgraeve.com/hyperterminal/>

When using RS232 / USB communication please remember the following,

- Only one of these ports can be used to communicate with the unit at any given time as they share the same internal circuit board connections.
- For users that are communicating via RS232 and have a network interface card installed, the Ethernet communication will be paused when connected over RS232. Ethernet communication will resume when the RS232 connection is disconnected.
- The USB port is not for USB communication. This port only allows serial RS232 communication, normally done using 9-pin serial cable, to be done using a more common, USB cable.

❖ 6.2 PuTTY Settings

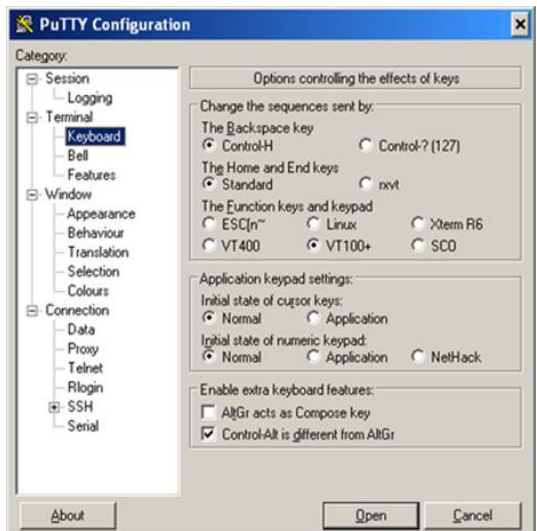
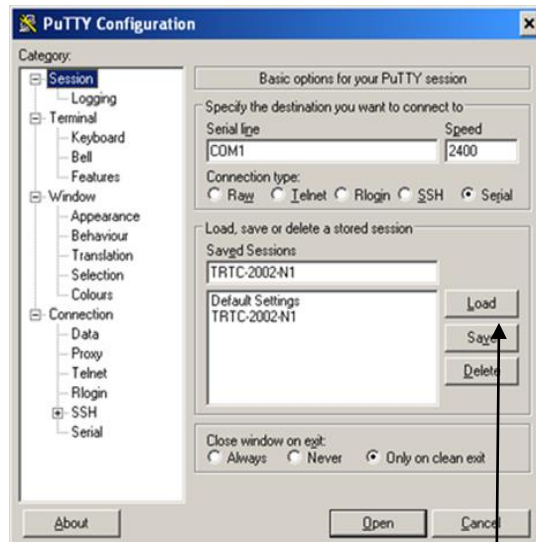
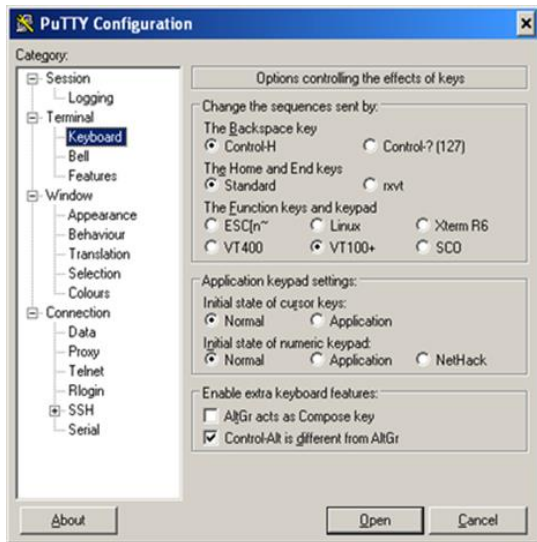
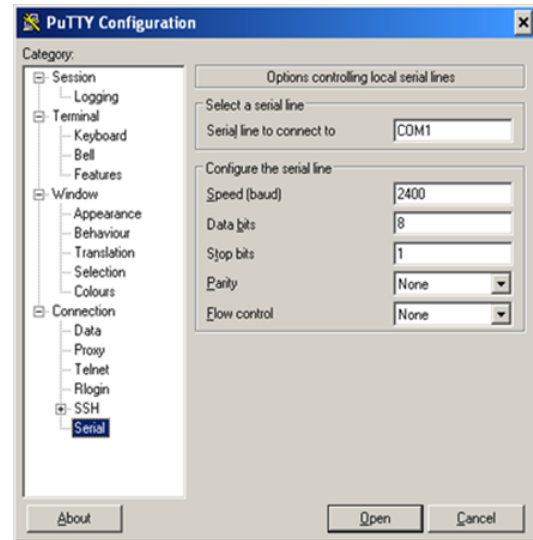

Remember to return to the Session Panel and hit save, to save your settings.

❖ 6.3 HyperTerminal Settings

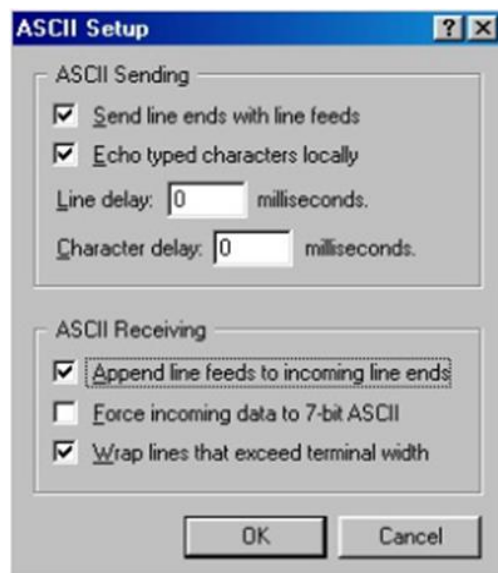
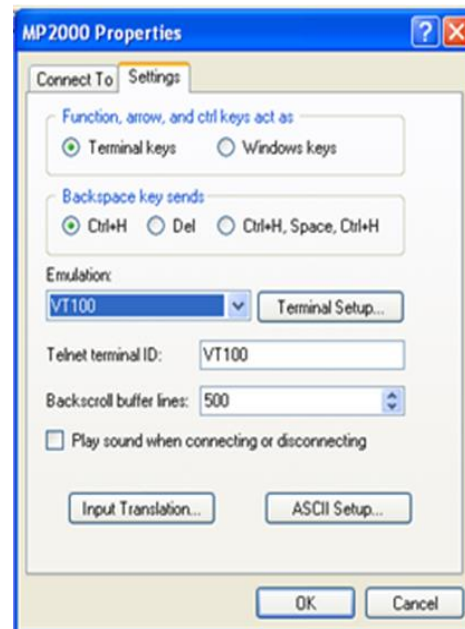
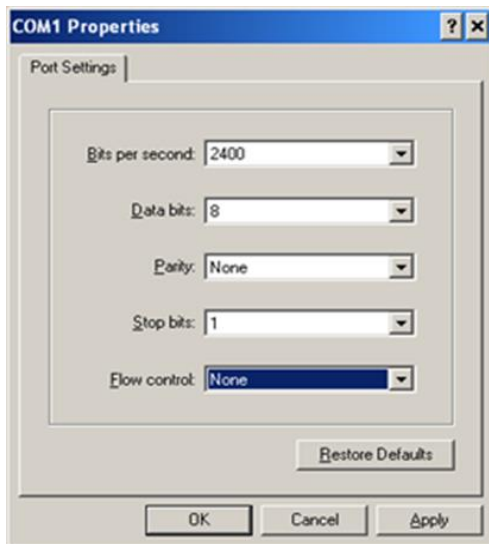
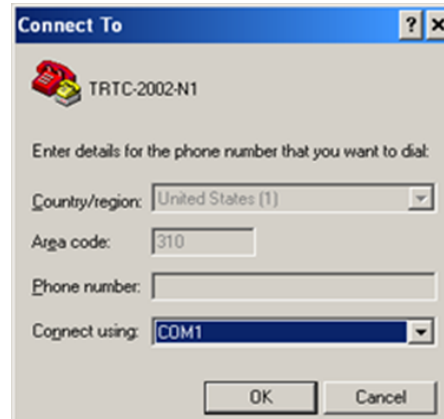

❖ 6.4 Menu Tree

Hyper Terminal Menu Tree [0 – MAIN MENU]

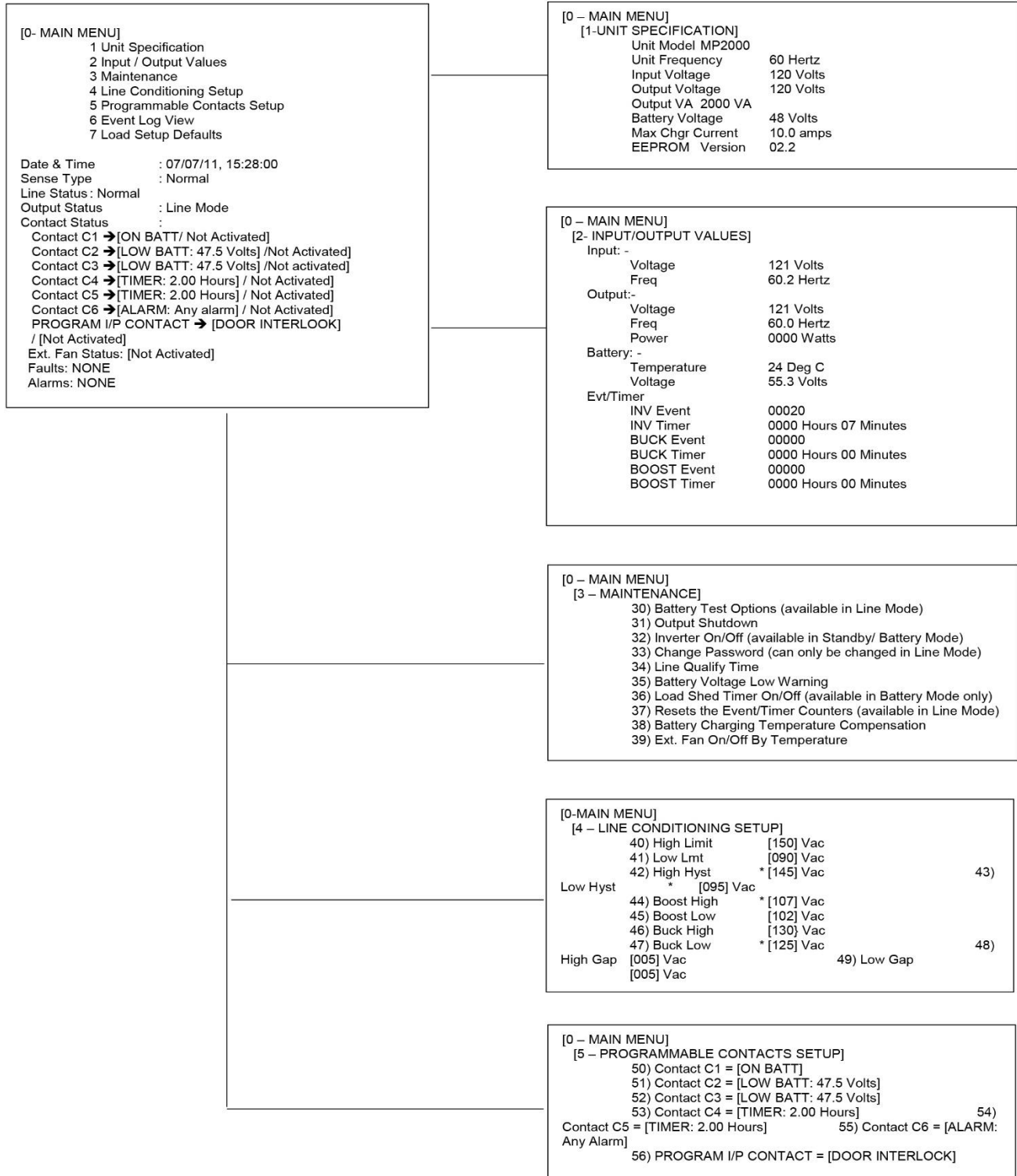

Hyper Terminal Menu Tree [3 – MAINTENANCE]

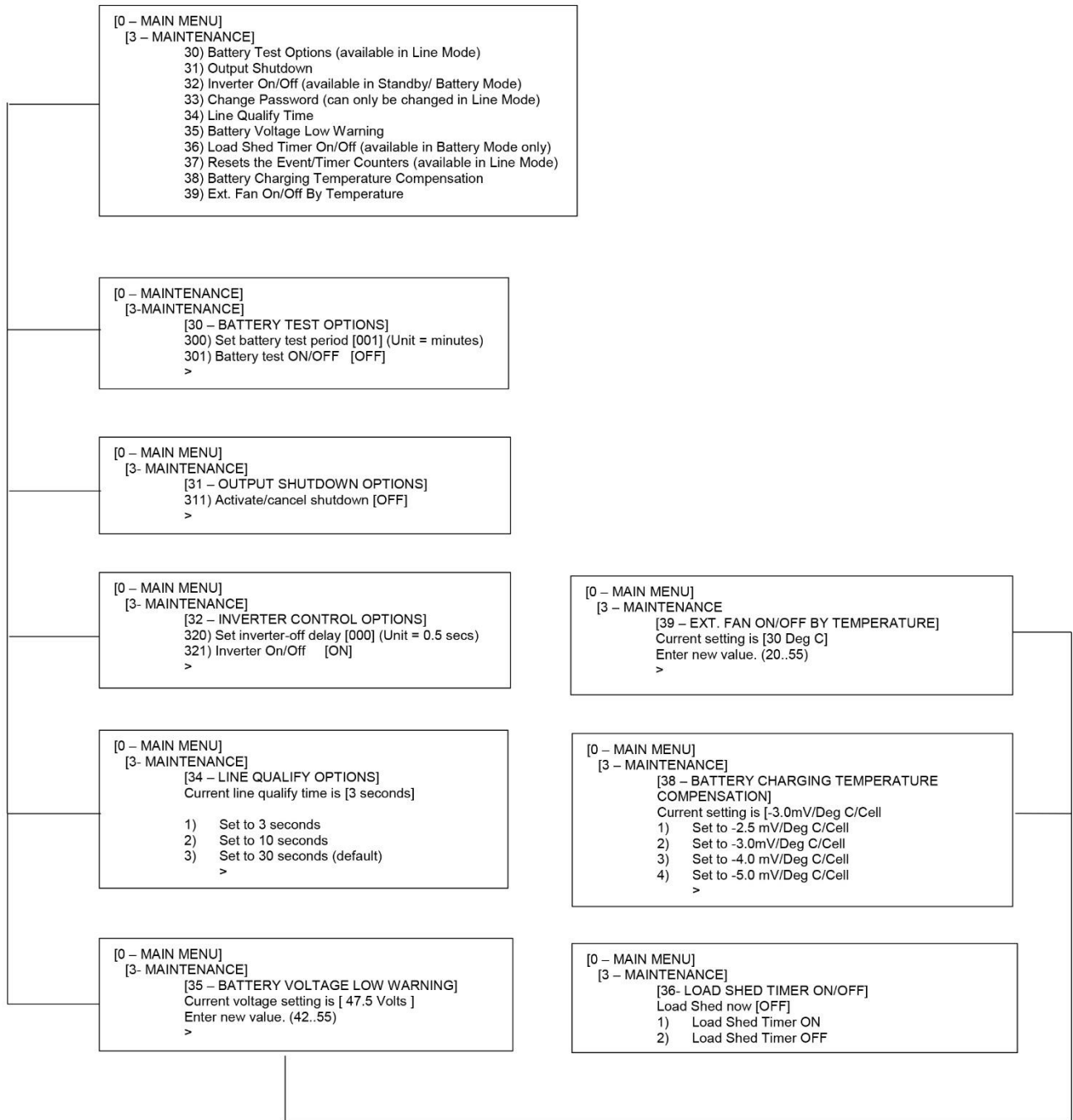

Hyper Terminal Menu Tree

[4 – LINE CONDITIONING SETUP]

[0-MAIN MENU]	
[4 – LINE CONDITIONING SETUP]	
40) High Limit	[150] Vac
41) Low Lmt	[090] Vac
42) High Hyst	* [145] Vac
43) Low Hyst	* [095] Vac
44) Boost High	* [107] Vac
45) Boost Low	[102] Vac
46) Buck High	[130] Vac
47) Buck Low	* [125] Vac
48) High Gap	[005] Vac
49) Low Gap	[005] Vac

HIGH LIMIT [150]
Enter new value. (120..150)
>

Hyper Terminal Menu Tree [5 – PROGRAMMABLE CONTACTS SETUP]

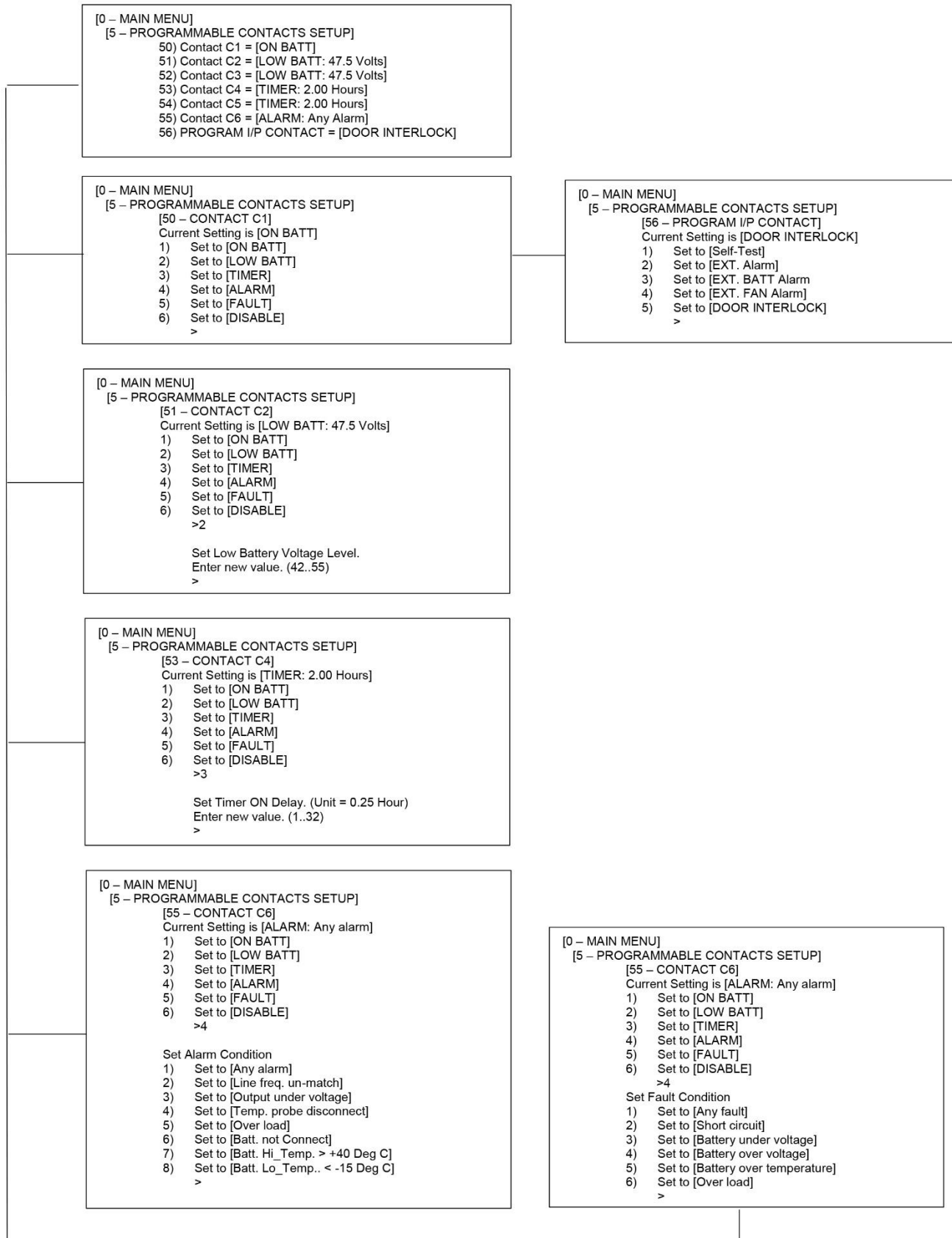

❖ 6.5 Main Menu

Purpose: *Describes the Main Menu.*

The RS232 / USB menus are hierarchical. Press **ENTER** to access the top-level menu.

The main menu displays the sub menu numbers, the line status, the unit's output status and any faults or alarms that may be present.



TIP:

The factory set default password 1111 is required to access and set many functions.

Sub Menu Numbers

Status, Faults, and
Alarms Readouts

```
TRTC-2002-N1

[0-MAIN MENU]
1 Unit Specification
2 Input / Output Values
3 Maintenance
4 Line Conditioning Setup
5 Programmable Contacts Setup
6 Event Log View
7 Load Setup Defaults

Date & Time   : 07/06/11, 16:16:57
Sense Type    : Normal
Line Status   : Normal
Output Status : Line mode
Contact Status:
Contact C1 ==> [ON BATT]/[Not Activated]
Contact C2 ==> [LOW BATT: 47.5 Volts]/[Not Activated]
Contact C3 ==> [LOW BATT: 47.5 Volts]/[Not Activated]
Contact C4 ==> [TIMER: 2.00 Hours]/[Not Activated]
Contact C5 ==> [TIMER: 2.00 Hours]/[Not Activated]
Contact C6 ==> [ALARM: Any alarm]/[Not Activated]
PROGRAM I/P CONTACT ==> [Self-test]/[Not Activated]
Ext. Fan Status: [Not Activated]
Faults: NONE
Alarms: NONE
```

Menu Tree



TIP:

The Status, Faults, and Alarms readouts are not automatically updated. Press ENTER to obtain the up to date status.

Tabulation of various items that appears under the Line Status, Output Status, Faults and Alarms are shown in the following tables.

Line Status: [Current Status]
 Output Status: [Current Status]
 Content Status: [Current Status]
 Ext. Fan Status: [Current Status]
 Faults: [If any, otherwise blank]
 Alarms: [If any, otherwise blank]
 >_

LINE STATUS	
Normal	Input power is normal.
Buck	Input power is out of tolerance. Buck mode is activated.
Blackout	Input voltage is not available.
Low	Input voltage is lower than programmed low limit.
High	Input voltage is higher than programmed Hi limit.
Freq low	Input frequency is too low (<55 Hz)
Freq high	Input frequency is too high (>65 Hz)

Line Status Displays

Line Status: [Current Status]
 Output Status: [Current Status]
 Content Status: [Current Status]
 Ext. Fan Status: [Current Status]
 Faults: [If any, otherwise blank]
 Alarms: [If any, otherwise blank]
 >_

OUTPUT STATUS
Line mode
Inverter mode
Inverter mode. Low bat. Warning
Boost mode
Buck mode
Hot swap mode
Shutdown due to fault
Shutdown due to low battery
Shutdown due to no line

Output Status Displays

Line Status: [Current Status]
 Output Status: [Current Status]
 Content Status: [Current Status]
 Ext. Fan Status: [Current Status]
 Faults: [If any, otherwise blank]
 Alarms: [If any, otherwise blank]
 >_

FAULT DISPLAYS	
Short-Circuit	Output Short Circuit
Vout_Hi	Output Voltage High
Vbat_Hi	Battery Voltage High
Vbat_Lo	Battery Voltage Low
Temp_Hi	Ambient Battery Temperature High or Internal Temperature High
Lout_Hi	Output Current High
EEPROM_ERROR	Error Reading EEPROM
Wout_Hi	Output Power High (Overload)
Bad Battery	Bad Battery
ALARM DISPLAYS	
Vout_Lo	Output Voltage Low
Lout_Hi	Output Current High
Overload	Output Overload
Temp_Hi	Ambient Battery Temperature High
PII	Ambient Battery Temperature Low
Line Freq	Phase Lock Loop Cannot Lock w/ Input
Temp_Probe_Disconnect	Temperature probe uninstalled or disconnected
Batt_Brk_Off	The battery breaker is off or the batteries are discharged
Program Input Alarm	The program input contact alarm detected.

Fault Alarm Displays

❖ 6.6 Sub Menus

Purpose: Describes the RS232 / USB Menu Tree that include: Unit Specifications, Input / Output Values, Maintenance and Line Slow Detection Setup Sub Menus.



TIP:

To access any item from the Main Menu. Type in the function number and press ENTER.

❖ 6.7 Unit Specifications

Menu 1 below lists the TRTC-2004-N1's specifications.

Procedure: At the main menu, type **1** and press Enter. The screen displays the Unit Specifications as shown below. To return to the main menu, press **Enter**.

[1 - Unit Specifications]		
Unit Model	TRTC-2004-N1	The model name
Unit Freq	60 hertz	Nominal operating frequency
Input Voltage	120 Volts	Nominal Input voltage
Output Voltage	120 Volts	Nominal output voltage
Output VA	2000 VA	The output VA capacity
Battery Voltage	48 Volts	Nominal battery capacity
Max Charge Current	10 amps	MAX charge capacity
EEPROM Version	02.2	EEPROM version of the TRTC-2004-N1

❖ 6.8 Input / Output Values

Menu 2 below lists the actual measurements of various input / output parameters.

Procedure: At the main menu, type 2 and press Enter. The screen displays the Unit Specifications as shown below. To return to the main menu, press **Enter**.

[2 – Input / Output Value]		
INPUT		
Voltage	120 Volts	The Input voltage
Freq	60.0 Hertz	The Input frequency
OUTPUT		
Voltage	120 Volts	The output voltage
Freq	60.0 Hertz	The output frequency
Power	0000 Watts	The output power in watts
BATTERY		
Temperature	25 Deg C	The ambient temperature of the battery case as read via attached temperature probe
Voltage	55.3 Volts	The battery DC voltage

EVT/TIMER		
INV Event	00019	The numbers of Input Power Failures
INV Timer	0000 Hours 07 Minutes	Total time that the battery was discharged since the last RESET
BUCK Event	00000	The numbers of BUCK function active
BUCK Timer	0000 Hours 00 Minutes	Total time that the BUCK function since the last RESET
BOOST Event	00000	The numbers of BOOST function active
BOOST Timer	0000 Hours 00 Minutes	Total time that the BOOST function since the last RESET

❖ 6.9 Maintenance

Menu 3 below lists the various maintenance options.

Procedure: At the main menu, type 3 and press ENTER. The Maintenance Menu shown below is displayed. To return to the main menu, press ENTER.

[3 - Maintenance]	
30 Battery Test Options	<p>The start - stop for the Battery Test / Self-Test is initiated here. The test duration is user programmable in 1 minute intervals from 1 to 255 minutes. The factory default setting is 1 minute.</p> <p>Tip: The time duration can be changed only when TRTC-2004-N1 is in line mode.</p>
31 Output Shutdown	<p>This allows output to be switched OFF or Shutdown. TRTC-2004-N1 switches to STANDBY mode when this option is activated.</p>
32 Inverter On/Off	<p>During the BATTERY or STANDBY mode, this option allows the inverter to be switched OFF or turned ON after the user programmable delay time.</p> <p>The delay can be user programmable in 0.5 seconds steps from 0 to a maximum setting of 255 steps (128 seconds). The delay is only available in Standby or Battery modes. When the unit returns to Line Mode, the delay resets back to a default of 0 seconds.</p> <p>Thus during a battery discharge or ON BATTERY mode, operator can stop the inverter immediately after user.</p>
33 Change Password *	<p>This option allows for the change of password. The factory set default password is 1111.</p> <p>Tip: the password can only be changed in Line mode.</p>
34 Line Qualify Time	<p>When the input power returns and it is qualified, i.e. it is within acceptable range, the transfer from Battery mode to Line mode is delayed by user programmed 3 / 10 / 30 seconds herein that allows the returned utility power to settle down. The factory set default value is 30 seconds.</p>
35 Battery Voltage Low Warning	<p>The level for LOW BATTERY ALARM is set here. The Voltage level is user programmable in 0.5VDC increments from 42VDC to 55VDC. The factory default setting is 47.5VDC</p>

	or 40%). The relationship between Remaining % capacity of battery and its DC Voltage depends on the characteristics of the batteries used.
36 Load Shed Timer On/Off	The programmable timer contacts are manually activated / deactivated ON DEMAND using this option. Certain Loads / Signals connected to this timer can be shed or dropped earlier to extend the back-up time. This function is available only in "Battery Mode".
37 Resets The Event/Timer Counters	Resets INV, BUBK, BOOST Event to 0 Resets INV, BUBK, BOOST Timer to 0
38 Battery Charging Temperature Compensation	Temperature compensated smart charger is utilized in TRTC-2002-N1. The rate of charging is adjusted here based on the battery case temperature. The factory default value is set at -3mv/deg°C /Cell. It can be configured to -3 / -4 / -5 mv/deg°C /Cell.
39 Ext. Fan On/Off By Temperature	Set the temperature in °C, above which the 48VDC power will be provided for external cooling fan. The temperature can be set in 1°C increment from 20 to 55°C. The factory default temperature is set at +25°C.

*Password Changing Procedure

1. Type the current password (the factory set password is 1111) and press **Enter**.
2. The words "Enter New Password" appears on the screen. Type the new password (any combination of 4 digits) and press **Enter**.



NOTE:

The password can only be four numeric digits – NO ALPHA CHARACTERS.

3. The words "Re-enter New Password" appear on the screen. Retype the new password and press **Enter**. If the wrong password is retyped, the screen displays "Error in entering data... please try again." Type the correct password and press **Enter**.

If the retyped password is correct, the screen returns to the main menu.

❖ 6.10 Transfer Point Parameters

This option allows user to change various detection and warning levels for input AC voltages, qualified and unqualified values, Transfer & Retransfer set points for going in & out of Battery mode / Boost / Buck modes. The factory set default values concur with those specified by major DOTs (Department of Transportations).

Electrical equipment is designed to operate at maximum efficiency at a specific standard supply voltage. Buck and boost is an ideal solution when the line voltage is consistently higher or lower than nominal. The transformer can buck (lower) or boost (raise) the supply voltage without having to go onto battery or involve any other active TRTC-2004-N1 board level components. The TRTC-2004-N1 input transformer has a second tap off the primary winding. When activated, the transformer will automatically switch to the secondary tap to buck or boost the voltage output 10%, thereby keeping the output within an acceptable range.



ATTENTION!

Improperly set parameter values can cause permanent damage to the unit. Changes should only be made by Manufacturer trained personnel. Contact Manufacturer before making any adjustment.



NOTE:

Parameter values are interdependent, changing one value can affect range and permissible value in another field. This feature is to protect the user from entering conflicting values.

❖ 6.11 Parameter Change Procedure

1. “Enter Password” appears (the factory set password is 1111), Type the password and press **Enter**.
If the wrong password is typed, the screen displays “Error in entering data... please try again.” Type the correct password.
2. The Parameter Change Screen appears. Type the new value that is within the range of acceptable parameter limits and press **Enter**.

❖ 6.11 Transfer Point Descriptions



NOTE:

All levels are user programmable; some values are interdependent.

	range	effect. lower limit	effect. upper limit	Buck On Boost On	Buck Off Boost Off
Hi Lmt	120-150	120	150	150	130
Hi Buck	120-144	120	144	130	125
High gap	3-7	3	7	5	5
Low gap	3-7	3	7	5	5
Lo Boost	96-120	96	120	102	105
Lo Lmt	90-120	90	120	90	100

40 Slow Detect High Lmt

When input voltage exceeds this level, TRTC-2004-N1 transfers to Battery Mode from either Buck Mode (when enabled) or Line mode.

42 Slow Detect High Hyst

When input voltage returns below this level, TRTC-2004-N1 transfers back to Line Mode from Battery Mode.

43 Slow Detect Low Hyst

When input voltage returns above this level, TRTC-2004-N1 transfers back to the Line Mode from Battery Mode.

44 Slow Detect Boost High

When input voltage returns above this level, TRTC-2004-N1 releases the Boost Mode (when enabled) and transfers back to the Line Mode.

45 Slow Detect Boost Low

When input voltage reduces below this level, TRTC-2004-N1 transfers to Boost Mode (when enabled) increasing the output.

46 Slow Detect Buck High

When input voltage exceeds this level, TRTC-2004-N1 transfers to Buck Mode (when enabled) reducing the output.

47 Slow Detect Buck Low

When input voltage returns below this level, TRTC-2004-N1 releases the Buck Mode (when enabled) and transfers back to the Line Mode.

48 High Gap

49 Low Gap

Section 7: Adjustments

- ❖ 7.1 Back-Up Time Test
- ❖ 7.2 Sense Mode - Normal and Generator Waveforms



❖ 7.1 Back-Up Test

Purpose: Describes how to measure the back-up capacity of batteries.

This test provides the measurement of back-up time during power outage by actually discharging the batteries. The back-up time is load as well as battery dependent, thus more back-up time is available with a lower load (in Amps or Watts) and less time with more load.

EXAMPLE:

Start time is **1PM**.
ON BAT contact if selected, is activated.

Low Battery Alarm LED appears at **4PM**.
LOW BAT contact at selected value will be activated.

Low Battery capacity battery back-up time will be the time difference between 4PM and 1PM or **3 hours**.

Shutdown time is **5PM**.
Battery reserve time will be the time difference between 4PM and 5PM or **1 hour**.

The **Total Battery Back-up** time is the sum of Low Battery capacity back-up time and Battery Reserve time or the time difference between 5PM and 1PM or 4 hours.



TIP:

It is recommended to perform this test every **6 months**. Make sure the batteries are fully charged before starting this test.

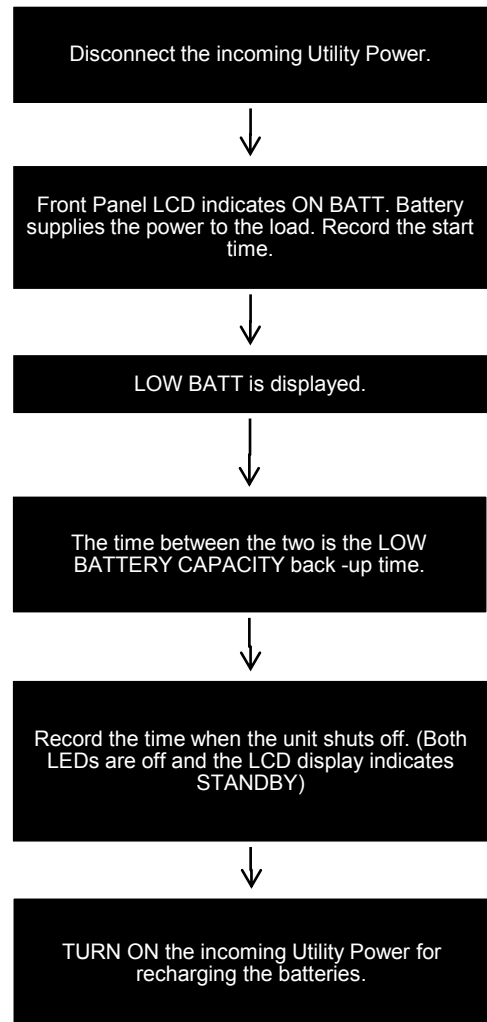

❖ 7.2 Sense Mode - Normal and Generator Waveforms

This is used to broaden the input parameters to accommodate the voltage fluctuations created by a backup generator or a noisy line.

The factory default setting is normal, where the unit runs on normal parameters. Switching to Generator makes it run on noisy generator parameters.

If the unit constantly switches between line and battery modes due to a noisy line, select generator mode to prevent unnecessary transfers / returns.

In generator mode, the acceptable range of input frequency and voltage is expanded to accommodate the voltage and frequency fluctuations created by a generator or a power source of such kind.

Use a generator with electronic speed and voltage controls which typically produces Total Harmonic Distortion in % (THD) of less than 10%. Generators with mechanical governors can force the system to run continuously in Battery mode.

Before installation, compare the generator's output voltage to the TRTC-2004-N1's input voltage requirements as listed on both nameplates. To insure the system's smooth operation, use a generator capable of supplying 2X or twice as much power as required by the total load.

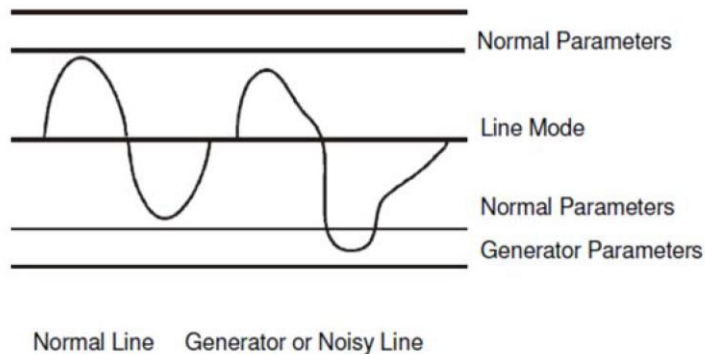

Section 8: Troubleshooting & Maintenance

- ❖ 8.1 Troubleshooting Sequence Chart
- ❖ 8.2 TRTC-2004-N1 Troubleshooting
- ❖ 8.3 PTS Troubleshooting
- ❖ 8.4 Alignment Procedure – Battery Backup Test
- ❖ 8.5 Battery Care



❖ 8.1 Troubleshooting Sequence Chart

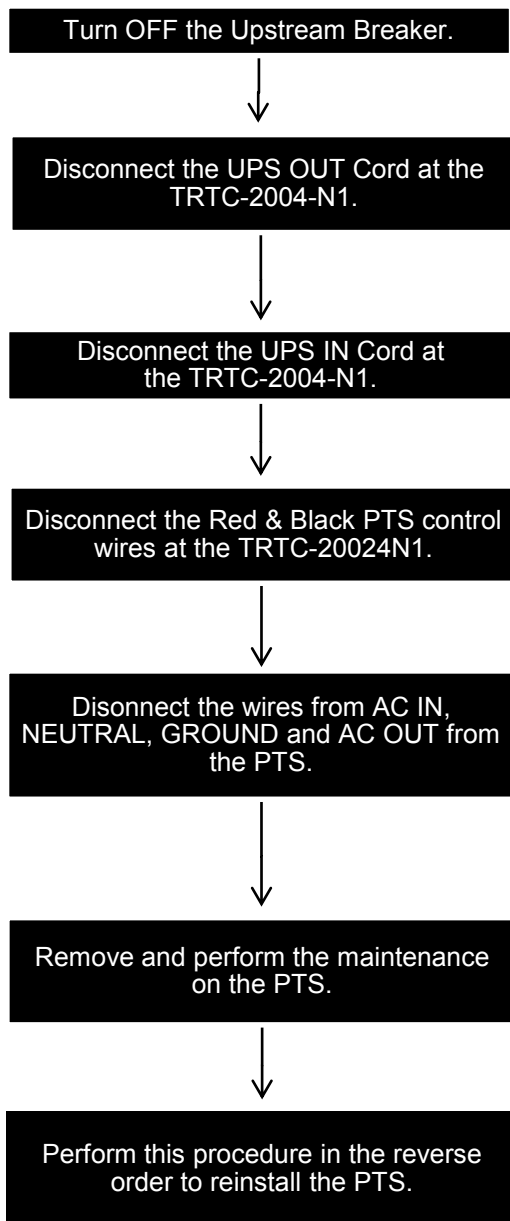

NOTE:

IMPORTANT: Verify that both the AC INPUT & OUTPUT and Battery Breaker are OFF at the TRTC-2004-N1.



NOTE:

IMPORTANT: Place the Manual Bypass Switch in BYPASS before doing any maintenance on the unit or PTS to prevent accidentally losing power to the traffic signals.

❖ 8.2 TRTC-2004-N1 Troubleshooting

Purpose: Describes the most common issues with the TRTC-2004-N1.

There are NO Maintenance items inside the TRTC-2004-N1 and it should be opened or serviced only by factory authorized service personnel, failure to do so will void the WARRANTY. If it fails to perform a specific function, the table below lists typical symptoms, causes and solutions. If you cannot resolve a problem, contact Manufacturer customer service department.

SYMPTOM	CAUSE	REMEDY
No Output	AC input & output circuit breaker is OFF.	Turn input & output circuit breaker on.
	No incoming utility line power.	Apply incoming utility power by closing upstream breaker.
	Red LED is lit solid on front indicating FAULT.	Read the FAULT under Status Menu of LCD display. Clear the fault. Shut off both the breakers on the front panel. Restart. Contact the factory, if fault persists.
Output LED OFF	Incoming utility power or battery power not available.	Apply qualified input power and verify battery breaker is closed.
	Faulty unit.	Contact factory.
Unit does not transfer to Battery mode during a power failure Or Backup time is less than rated	Battery not connected.	Connect batteries (48VDC nominal).
	Battery circuit breaker OFF.	Close battery breaker.
	Battery is not fully charged.	Fully recharge the battery then test the backup time.
	Dead battery.	Replace with a good battery.
	Battery failure.	Clean and tighten battery connections. Check batteries and replace if needed.
	Faulty unit.	Contact vendor.
Alarm LED is lit	Red LED steady ON indicates FAULT.	Correct the Fault.
	Red LED flashing indicates ALARM.	Correct the Alarm. Contact the factory if Alarm persists.
Batteries will NOT charge	Battery circuit OPEN.	Check that battery connections have proper torque. Check battery cable harness for connection error, loose / open connections. Check 46 to 53VDC present at the battery connector to TRTC-2004-N1 Check if battery breaker is closed Replace the bad battery, if any.
	Wrong or bad temperature probe connected at front panel.	Use Factory supplied temperature probe reading approximately 12,000 OHMS @ 25°C (77°F).
LCD screen NOT readable	Adjust the contrast for LCD screen.	Press and hold ESC button. Press ENTER button. Adjust the contrast using UP or DOWN arrow Buttons. Press ENTER when completed.
	Faulty unit.	Contact factory.
Password Access NOT available	Entered Password is LOST or forgotten.	Call factory for resetting of the new password.

❖ 8.3 PTS Troubleshooting

SYMPTOM	CAUSE	REMEDY
No Output available From PTS	Upstream utility circuit breaker or fuse may be OPEN.	Close the upstream utility breaker or fuse.
	Utility AC Power not available.	Check with the AC voltmeter & contact the Utility Company.
	Wiring error PTS terminal block.	Correct wiring at PTS.
	Faulty PTS.	If 120 VAC is present at "AC IN" and NEUTRAL at the PTS terminal block, replace the PTS.
PTS won't allow transfer to Battery mode	TRTC-2004-N1 output power not connected to PTS.	Verify that "UPS OUT" cord from PTS is properly connected to the AC OUTPUT terminal block at the TRTC-2004-N1.
	"UPS INPUT" circuit breaker at PTS is open.	Reset the breaker & clear the fault.
	Black and red control wires from PTS are not connected at the PTS connector on the TRTC-2004-N1.	Check the connection at the TRTC-2004-N1.
	48VDC signal missing at TB 21 and 22 of Green Control terminal block at the TRTC-2004-N1.	Refer to Section 9.2 for further troubleshooting.
	Faulty PTS.	Replace PTS.
TRTC-2004-N1 does not return back to input Line mode	Utility input line power is missing.	Verify that "UPS IN" cord from PTS is properly connected to the AC INPUT Terminal Block at the TRTC-2004-N1.
		Verify that the "UPS INPUT" circuit breaker at PTS is closed.
		Ensure that utility input is present.

❖ 8.4 Alignment Procedure – Battery Backup Test

Purpose: Describes how to measure the back-up capacity of batteries.

This test provides the measurement of back-up time during power outage by actually discharging the batteries. The back-up time is load as well as battery dependent, thus more back-up time is available with a lower load (in Amps or Watts) and less time with more load.



TIP:

It is recommended to perform this test every 6 months. Make sure the batteries are fully charged before starting this test.

EXAMPLE:

Start time is **1PM**.

ON BAT contact if selected, is activated.

Low Battery Alarm LED appears at **4PM**.

LOW BAT contact at selected value will be activated.

Low Battery capacity battery back-up time will be the time difference between 4PM and 1PM or **3 hours**.

Shutdown time is **5PM**.

Battery reserve time will be the time difference between 4PM and 5PM or **1 hour**.

The **Total Battery Back-up** time is the sum of Low Battery capacity back-up time and Battery Reserve time or the time difference between 5PM and 1PM or 4 hours.

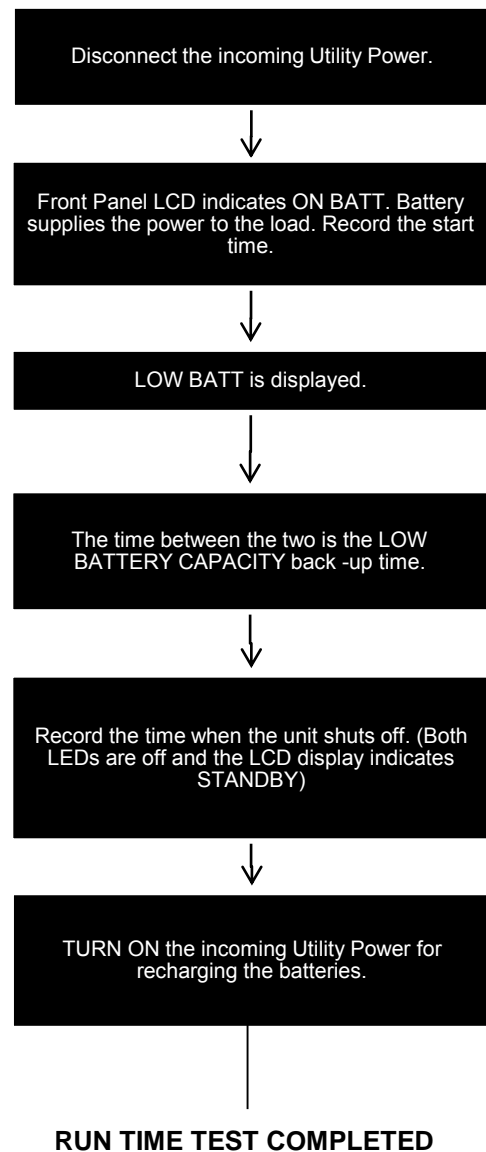

❖ 8.5 Battery Care

This is intended only as general information for customers and end users of Marathon Power UPS product with lead-acid storage batteries.

Customers routinely have questions about the lifespan of batteries. There are several factors that all contribute to the useful life of the batteries used with the UPS:

1. The ambient temperature around the UPS.
2. How many times the batteries are discharged and recharged.
3. How well the batteries were stored and maintained, both prior to installation and during the life of the UPS.

The life span of the batteries is typically 3-5 years. Whether it's closer to 3 years or 5 years depends primarily on the factors above. For cooler operating environments, with fewer discharge/recharge cycles on well-maintained batteries, the life expectancy of a battery can approach up to 5 years. On the contrary, in the operating environments with extreme heat and moisture and numerous discharge/recharge cycles with poorly stored and maintained batteries the life of a battery can be reduced to two to three years.

If batteries are overly discharged or left standing in the discharged state for prolonged periods, hardened lead sulfate coats the electrodes and will not be removed during recharging. Such build up reduces the efficiency and life of the batteries and may permanently damage the battery. Also, over-charging can cause electrolyte to escape as corrosive gases. If a battery that has been damaged due to its internal chemistry as described above is used in a UPS, it can appear to the charging circuit as a "short circuit" causing excessive current to flow through the input and charger circuits and consequently destroying them.

- High & **dangerous voltages** are present inside the system. Only qualified personnel should perform installation and maintenance.
- Live battery wires **must not** touch the TRTC-2004-N1 chassis or any other metal objects. ***This can cause a fire or explosion.***
- **Inspect** the batteries once a year for signs of cracks, leaks, or swelling. Replace as needed.
- When batteries are in storage, **charge** them at least once every three months for optimum performance and to extend their lifetime.
- **Always** replace batteries with the ones of identical type and rating. **Never** install old or untested batteries. **Never** mix old with new batteries. **Never** mix the different amp hour rated batteries within one system.
- Use **insulated tools** during servicing.
- **Remove** all rings, watches, jewelry, or other conductive items before working inside the enclosure.
- **Follow** local regulations for the disposal of batteries. Recycling is the best method.
- **Never** burn batteries to dispose of them. ***They may explode.***
- Do not open the batteries. ***The contents are toxic.***

Storage Notes

Please adhere to the following storage instructions if the UPS is not to be installed shortly after the delivery.

1. Store the unit as is in its original packing and shipping container.
2. The optimum storage temperature range is 5°F to 77° (-5°C to +25°).
3. Ensure that the equipment is fully protected from wet or damp areas and from moisture.
4. Ensure that the UPS is recharged every 6 months for at least 8 hours in order to maintain battery energy and maximize useable life.

APPENDICES

- ❖ TRTC-2004-N1 Specifications
- ❖ PTS Specifications
- ❖ Transfer Point Descriptions

❖ TRTC-2004-N1 Specifications

Functions	
Brownout Protection	This unit boosts the output voltage (or transfers to battery) during brownout or low input line conditions and returns to On Line when input power stabilizes and returns to normal. The values for Transfer / Retransfer, To / From Battery / Boost mode are user programmable.
Generator Compatibility	Generator mode allows for more variations in input voltage and frequency for use with an AC generator.
Battery Charger 10A	PFC switch-mode charger is temperature-compensated (-3 to -5 mV/°C /Cell) with automatic shut off above 50°C.
Inverter Mode	Capable of running continuously in inverter mode.
Inverter Mode Current Limit	Continuous electronic current limit is provided.
Measurements available for remote monitoring	<ul style="list-style-type: none"> - Input and output voltages - Input line frequency - Battery voltage and current - Battery and heat sink temp
Mechanical Specifications	
Dimensions (H x W x D), inch (mm)	5.25" x 17" x 10.5", 3U size (133 mm x 432 mm x 267 mm)
Weight, lb (kg)	46.2 (21)
Input Connection	Anderson PP45/4P Connect
Output Connection	Anderson PP45/4P Connect
Mounting	19" (483 mm) or 23" (584 mm) rack or shelf mount
Cooling	Microprocessor controlled, 12VDC, 3.62" (92 mm) fan
Audible Noise Level, dBA	<40
Operating Temperature, °C	-37° to +74°C (See Notes 1 and 2)
Storage Temperature °C	-50° to +75°C
Humidity	Less than or equal to 95%, Non-Condensing
Altitude, ft (m)	10,000 (3048) (See Note 2)

Electrical Specifications	
Output Apparent Power, VA	2000 (Inverter Mode) 2000 (Line Mode)
Output Active Power, W	1500 (Inverter Mode) 1500 (Line Mode)
Power Factor	0.75
Input Frequency, Hz +/- 3HZ	60
Input Voltage Range, VAC	90 to 150 VAC User programmable. Defaults set @ 100~ 130 VAC +/- 2 VAC.
Output Voltage Inverter Voltage	120 Nom (Tolerances are user programmable) 120 VAC +/- 5%
Maximum Input Current, A	30
Transformer	Linear (Non-Isolated)
Transfer Time, msec	<65 msec. Buck & Boost enable <10 msec.
Inrush Current	Load dependent
Output Waveform THD, %	< 3 (Resistive Load)
Load Crest Ratio	3:1
Efficiency, Line Mode	> 95% (Resistive Load)
Efficiency, Inverter Mode	> 80% (Resistive Load)
Nominal Battery String 48VDC Voltage, VDC	48VDC
Step Load Response (50%)	1 Cycle full recovery
Over current Protection	Double Pole Single Throw Circuit Breaker Rated at 30 Amp for input and output DC Bus: 60 Amp circuit breaker
Transient Suppression	MOV transient suppression elements (>150V)
DC Power	Drawn from batteries



NOTE:

1. Between 55° and 74°C, the unit is de-rated to a maximum load of 1600VA/1200W.
2. De-rate operating temperature above 4900 ft. (1500m) by 5 deg. C per each additional 1000ft. (300m).

22 Position Terminal Block	
Functions	<p>A. Provides 6 sets of programmable contacts at pin 1 thru pin 18 for intersection flash control, Remote Alarms, Pagers or other user interface.</p> <ol style="list-style-type: none"> 1. "Low Batt": batteries have reached approximately 40% capacity remaining 2. "On Batt": unit is in inverter mode 3. "Timer": unit has been in inverter mode for 2 hours (programmable) 4. "Alarm": any of the following conditions occur: <ol style="list-style-type: none"> a. Line Frequency error b. Low Output voltage c. No Temperature Probe d. Overload e. No battery connected f. High temperature g. Low temperature 5. "Fault": any of the following conditions occur: <ol style="list-style-type: none"> a. Short circuit b. Batt low voltage c. Batt high voltage d. High temperature e. Overload <p>B. Provides 48 VDC signal to PTS on pins 21 & 22</p> <p>C. Provides programmable input contact on pins 19&20.</p> <ol style="list-style-type: none"> 1. Self-test 2. EXT Alarm 3. EXT Battery Alarm 4. EXT Fan Alarm 5. Door Interlock
Contact Type	Form C. Dry contacts rated 1 Amp at 120V
Wiring	Uses 14-26 AWG
Communication Specifications	
RS-232/USB/Ethernet ports	Monitors, controls and calibrates with terminal emulation software for service personnel to obtain unit diagnostics
RS-232	DB-9, Female, Opto-Isolated, straight-thru cable
USB	B-Type receptacle
Ethernet (optional)	10/100 Mbps Ethernet, auto-detected
Display Panel	2-line LCD



NOTE:

Specifications subject to change without notice. Certain functions require activation.

❖ PTS Specifications

INPUT	
Voltage Range, VAC	100~130VAC (120 VAC Nominal) Prog. 90–150VAC
Frequency	60 +/- 3 Hz
Current	30A (Resistive)
Step Load Response (50% Load Change)	½ Cycle Full Recovery (Full resistive load)
Short Circuit Protection	15A circuit breaker
Battery String Voltage	48VDC (Four 12VDC Battery)
OUTPUT	
Power, VA / W (Line or Inverter mode)	2000VA / 1500W
Power Factor	0.75
Output Voltage, VAC Line and Boost Mode	100~130 +/- 2 VAC (follows the input voltage)
Inverter Mode	120VAC +/- 5%
Output Waveform	Sine Wave
Output Waveform THD	< 3% (Resistive load)
Load Crest Factor	3:1 (Max)
Overload Capacity	110% for 3 minutes
PERFORMANCE	
PTS Transfer Time	< 65 ms Buck & Boost mode <10 ms

ENVIRONMENTAL	
Operating Temp (See Notes below)	
Storage Temp	-50 to +75 °C
Humidity (Non-Condensing)	<95%
Attitude (Note 2)	10,000ft /3000 m
PTS MECHANICAL	
Dimensions (WxDxH) inch/mm	4.75/120.6 (W) 6.5/165 (D) 4.6/116.8 (H)
Weight (lb/kg)	7.0/3.2
Mounting	Rack Mount EARS, 4 points Optional 19" rack mount
Input Connection	Terminal block
Output Connection to Loads	Terminal block
Output Connection to UPS	6 foot line cords ready for hard wiring to UPS terminal blocks
Cooling	Convection (Approx. 7 W contactor coil dissipation)
DESIGNED TO CONFORM TO	
Meets	TEES, July 2009, 2009 TEES Errata 1, Jan. 2010, 2009 TEES Errata 2, Dec. 2014, TEES, Ch. 4 - BBS, July 2009
EMI	FCC Class A
Surge Immunity	IEC 1000-4-5, IEEE C62.41



NOTE:

1. Between 55 ~ 74 °C, the system is de-rated to a maximum rectified-capacitive load of 1500 VA /1200 W.
 2. De-rate operating temperature above 4900 ft (1500m) by 2°C per 1000 ft. (300m).
 3. Refer to the Appendix TRTC-2004-N1 for additional specifications.
- Due to ongoing improvements, specifications subject to change without notice.

❖ Transfer Point Descriptions



NOTE:

All levels are user programmable; some values are interdependent.

	range	effect. lower limit	effect. upper limit	Buck On Boost On	Buck Off Boost Off
Hi Lmt	120-150	120	150	150	130
Hi Buck	120-144	120	144	130	125
High gap	3-7	3	7	5	5
Low gap	3-7	3	7	5	5
Lo Boost	96-120	96	120	102	105
Lo Lmt	90-120	90	120	90	100

40 Slow Detect High Lmt

When input voltage exceeds this level, TRTC-2004-N1 transfers to Battery Mode from either Buck Mode (when enabled) or Line mode.

42 Slow Detect High Hyst

When input voltage returns below this level, TRTC-2004-N1 transfers back to Line Mode from Battery Mode.

43 Slow Detect Low Hyst

When input voltage returns above this level, TRTC-2004-N1 transfers back to the Line Mode from Battery Mode.

44 Slow Detect Boost High

When input voltage returns above this level, TRTC-2004-N1 releases the Boost Mode (when enabled) and transfers back to the Line Mode.

45 Slow Detect Boost Low

When input voltage reduces below this level, TRTC-2004-N1 transfers to Boost Mode (when enabled) increasing the output.

46 Slow Detect Buck High

When input voltage exceeds this level, TRTC-2004-N1 transfers to Buck Mode (when enabled) reducing the output.

47 Slow Detect Buck Low

When input voltage returns below this level, TRTC-2004-N1 releases the Buck Mode (when enabled) and transfers back to the Line Mode.

48 High Gap

49 Low Gap

LCD Menu Tree

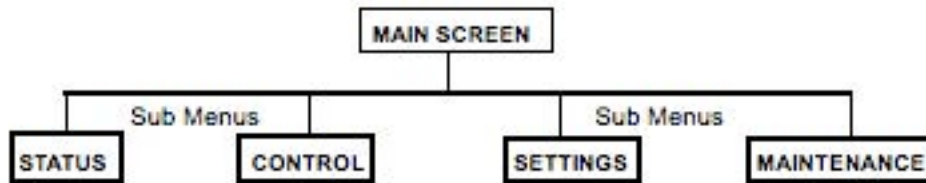

STATUS

01	V (in) = 120.0 VAC
	F (in) = 60.0 Hz
02	V (out) = 120.0 VAC
	P (out) = 1500 Watts
03	V (batt) = 55.2 VDC
	Battery Temperature = +27 °C
04	Inv. Event = 65536
	Inv. Timer = 0002.4H
05	Buck Event = 65536
	Buck Timer = 0002.4H
06	Boost Event = 65536
	Boost Timer = 0002.4H
07	C1=OFF C2=OFF C3=OFF
	C4= OFF C5= OFF C6=OFF
08	UPS Version = 4.0
	LCD Version = 4.0
09	IPA = 192.168.001.051
	MSK = 255.255.255.00
	GWY = 192.168.001.001
10	2)
	Self-Test
11	Program Contacts (See Table 3)
12	Line Conditioning (See Table 4)
13	Alarms (See Table 5)
14	Faults (See Table 6)

CONTROL

01	Self-Test
02	Program Contacts Test
03	Ext. Fan Test
04	Manual On / Reset
05	Events / Timer Reset
06	Log Reset
07	Password Protection

SETTINGS

01	Program Contacts (See Table 3)
02	AVR Feature (See Table 7)
03	Line Qualify (3Sec, 10Sec, 30Sec)
04	Ext. Fan Control (Turn On @ 20 ~ 50°C)
05	Sense Type (Normal / Generator Mode)
06	Batt. Temp. Comp. (-2.5mV~5mV/°C/Cell)
07	Set Date / Time
08	Daylight Saving
09	Program I/P Contacts (See Table 2)

MAINTENANCE

01	Batt. Test Option
02	Inverter On / Off
03	Event Log View
04	Line Conditioning (See Table 8)
05	Change Password

TABLES

TABLE 1 – UPS STATUS	
01	SFTST
02	BOOST
03	ONLINE
04	BUCK
05	LOBAT
06	ONBAT
07	STNBY
08	ALARM (See Table 5)
09	FAULT (See Table 6)

TABLE 2 – PROGRAM I / P CONTACTS	
01	Self-Test
02	EXT Alarm
03	EXT Battery Alarm
04	EXT Fan Failure
05	Door Interlock

TABLE 3 – PROGRAM CONTACTS	
01	ON BATT
02	LO BATT (42.0-55.0V / 0.5V increment)
03	TIMER (0.25-8hr / 0.25 increment)
04	ALARM
05	FAULT
06	DISABLE

TABLE 4 – LINE DETECTION	
01	Hi Lmt = 150 VAC
	Hi Hyst = 145 VAC
02	Hi Buck = 130 VAC
	Lo Buck = 125 VAC
03	Hi Boost = 107 VAC
	Lo Boost = 102 VAC
04	Lo Hyst = 095 VAC
	Lo Lmt = 090 VAC

TABLE 5 – ALARAM MESSAGE	
01	Line Freq.
02	Low O / P Volt
03	NO Temp. Probe
04	Over Load
05	BATT not Conn
06	High Temp.
07	Low Temp.
08	Ext. Alarm
09	Ext. Batt Alarm
10	Ext. Fan Fail
11	Door Interlock
12	Complex Alarm

TABLE 6 – FAULT MESSAGE	
01	Short Circuit
02	BATT Low Volt
03	BATT High Volt
04	High Temp.
05	Over Load
06	Complex Fault

TABLE 7 – AVR FEATURE	
01	Buck Feature
02	Boost Feature

TABLE 8 – ALARM MESSAGE	
01	Hi Lmt = 150 VAC
02	Hi Buck = 130 VAC
03	High gap = 005 VAC
04	Low gap = 005 VAC
05	Lo Boost = 102 VAC
06	Lo Lmt = 090 VAC

❖ TRTC-2004-N1 Return Instructions

Purpose: Describes how to return the TRTC-2004-N1 for repairs.



NOTE:

Manufacturer does not assume responsibility for damage caused by improper packaging of returned units. The TRTC-2004-N1 weighs approximately 46 lbs. and should only be shipped in a box or carton of sufficient thickness to withstand handling.

Before returning a UPS or any system component for repair or replacement, including batteries, a Return Material Authorization (RMA) number must be obtained from Customer service at the following Telephone / Address. Clearly write the RMA number on the original shipping container. If you do not have the original container, pack the unit with at least three inches of shock absorbing material, but do not use popcorn type material. Returns should be prepaid and insured (COD and freight collect cannot be accepted).

Contact Customer Service for ordering any parts or service.

For service, parts or technical information contact:

Marathon Power is available for customer service between 7:00am and 6:00pm PST, Monday-Friday and can be contacted as follows:

Phone: 310-689-2328

Fax: 310-689-2329

Email: support@marathon-power.com

Website: www.marathon-power.com

Address: 2538 E. 54th St., Huntington Park, CA 90255



UPS PRODUCT INFORMATION

1. Limited Three-Year Warranty and Exclusions

Marathon Power warrants that this product at the time of its sale by Marathon Power, is free of defects in materials and workmanship for three (3) years from the original purchase date. The batteries used with our traffic units vary, and the battery warranty will follow the battery manufacturer's warranty. Marathon Power will make reasonable efforts to troubleshoot any suspected defects with a UPS system which is under warranty. This warranty excludes labor for removal or re-installation of this product. This warranty is void if this product is installed improperly or in an improper environment, overloaded, misused, opened, abused, or altered in any manner, or is not used under normal operating conditions or not in accordance with all labels or instructions. There are no other or implied warranties of any kind, including merchantability and fitness for a particular purpose, but if any implied warranty is required by the applicable jurisdiction, the duration of any such implied warranty, including merchantability and fitness for a particular purpose, is limited to three years. Marathon Power is not liable for incidental, indirect, special or consequential damages, including damage to, or loss of use of, any equipment, lost sales or profits or delay or failure to perform this warranty obligation.

2. Limitations & Claims

This warranty does not cover any Marathon Power UPS or any properly connected electronic equipment which has been improperly installed, overloaded, abused or altered in any manner, or is not used under normal operating conditions, or in accordance with any labels or instructions, and does not cover any damage to properly connected electronic equipment resulting from a cause other than a "surge". Damage caused by failure to provide a suitable installation environment for the product (including, but not limited to, lack of a good ground) will not be covered by this warranty. This warranty does not apply to damage caused by direct lightning strikes, or damage caused by electrical disturbances that exceed published product specifications. These products are intended to limit the maximum amplitude of transient voltage surges on power lines to specified values. They are not intended to function as surge arrestors. The UPS is intended to be installed on the load side of the service entrance and has been tested to verify that transient voltage surges are limited when subject to non-repetitive transient voltage surge events. This warranty excludes any incidental, indirect, special or consequential damages, including without limitation, labor for removal or reinstallation of the Marathon Power UPS or any connected electronic equipment, data loss or alteration loss of equipment use, lost sales or profits and any such damages for delay or failure to perform this warranty obligation. This warranty is in lieu of and excludes all implied warranties of merchantability or fitness for use. In addition, the warranty does not cover restoration of lost data and reinstallation of software. Some states may not allow the exclusion or limitation of incidental or consequential damages or other remedies, so the above exclusions or limitations may not apply to you. To file a warranty claim, contact us at Marathon Power, Inc., Attn: Returns, 2538 E. 54th Street, Huntington Park, California 90255, or call (310) 689-2328 or email us at support@marathon within 30 days of the occurrence. Marathon Power is not responsible for shipping costs. Be prepared to provide detailed information about the event, any damage, the model and serial number, purchase date and location. You will then be provided with a Return Material Authorization (RMA) Number, and be instructed to provide an explanation of the event and information about the state of your unit. If Marathon Power determines that the damage was due to a "surge", we may request that all connected equipment be submitted for evaluation. The warranty coverage is above and beyond, only to the extent needed, of that provided by any other source, including but not limited to any connected equipment coverage, any manufacturer's warranty or insurance policy.



© 2023 Marathon Power Inc.

2538 E. 54th Street
Huntington Park, CA 90255

Office: 310-689-2328

Fax: 310-689-2329

support@marathon-power.com

www.marathon-power.com