



# TRTC SERIES

Battery Backup System  
for Traffic Signals

Installation, Operation and Maintenance Manual  
For Models:

TRTC-0654-N1 TRTC-0654-N2  
TRTC-0654-H1 TRTC-0654-H2  
TRTC-1124-N1 TRTC-1124-N2  
TRTC-1124-H1 TRTC-1124-H2  
TRTC-2005-N1 TRTC-2005-N2  
TRTC-2005-H1 TRTC-2005-H2



# TABLE OF CONTENTS

IMPORTANT SAFETY INSTRUCTIONS.....5  
BATTERY SAFETY.....7  
UNPACKING AND INSPECTION CHECKLIST..... 7

## **SECTION 1 – INSTALLATION & START-UP.....9**

1.1.1 SYSTEM DESCRIPTION .....9  
1.1.2 FRONT PANEL LAYOUT .....10  
1.1.3 AUTO TRANSFER SWITCH .....11  
1.1.4 BATTERIES.....12

### **1.2 MOUNTING .....12**

### **1.3 WIRING .....13**

### **1.4 START-UP AND TEST .....16**

### **1.5 SHUTDOWN.....18**

1.5.1 TRTC UPS.....18  
1.5.2 ATS .....19  
1.6 TROUBLESHOOTING.....20  
1.7 EMERGENCY SHUTDOWN PROCEDURE .....21

## **SECTION 2 - FEATURES.....22**

2.1.1 THE ADVANTAGES.....22  
2.1.2 A TOUR OF THE TRTC SERIES.....23  
2.2.1 LCD PANEL .....28  
2.2.2 TRTC UPS OPERATING MODES.....29  
2.2.3 SELF TEST.....30  
2.2.4 START UP .....31  
2.2.5 SHUTDOWN.....32  
2.2.6 BATTERY REPLACEMENT.....33  
2.2.7 LCD MENU TREE .....34  
2.2.8 STATUS SUBMENU .....36  
2.2.9 CONFIG SUBMENU.....38  
2.2.10 MAINTENANCE MENU .....40  
2.2.11 ALARM MENU .....42

2.2.12 FAULT MENU .....	43
2.2.13 LOW BATTERY MODE STATUS .....	44
2.3.1 RS232/USB SET-UP.....	45
2.3.1.1 WIRING SET-UP PROCEDURE.....	45
2.3.2 HYPERTERMINAL SET UP.....	46
2.3.3 MAIN MENU .....	50
2.3.4 MENU TREE & RS232/USB SUB MENUS .....	53
2.3.4.1 RS232/USB MENU TREE.....	53
2.3.4.2 UNIT SPECIFICATIONS, INPUT / OUTPUT VALUES .....	54
2.3.4.3 INPUT / OUTPUT VALUES.....	54
2.3.4.4 MAINTENANCE.....	55
2.3.4.5 LINE SLOW DETECTION PARAMETERS.....	57
2.3.5 MENU TUTORIAL .....	60
2.4.1 BATTERY BACK-UP TIME TEST .....	62
2.4.2 BATTERY MAINTENANCE.....	63
2.4.3 EMERGENCY SHUTDOWN PROCEDURE .....	63
2.4.4 TROUBLESHOOTING.....	64
2.4.5 SPECIFICATIONS .....	66
2.4.6 TRTC SERIES RETURN INSTRUCTIONS .....	68
2.4.7 WARRANTY.....	69

## IMPORTANT SAFETY INSTRUCTIONS CONTAINED IN THIS MANUAL



To reduce the risk of electrical shock and to ensure the safe operation of the TRTC UPS, the important safety instructions are marked with the symbols as shown below. These symbols are used throughout this manual and wherever they appear, it indicates that the instructions should only be carried out by qualified personnel.

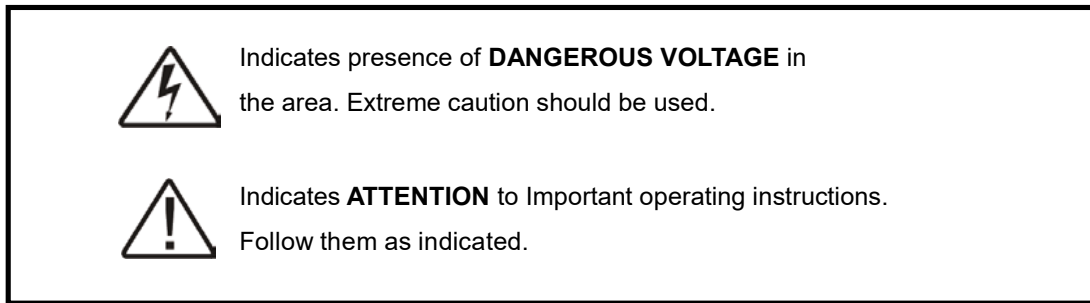

**DANGER:** Do not expose the TRTC UPS to rain or moisture.

**DANGER:** Total Earth ground leakage current of loads connected to the TRTC UPS should not exceed 2.4 mA.

The TRTC UPS generates, uses and can radiate radio frequencies if not installed and tested in accordance with the instructions contained in this manual. It has been tested and found to comply with the limits established for a Class A computing device pursuant to part 15 of FCC rules when it is operated alone. It also complies with the radio interference regulations of DOC, which are designed to provide a reasonable protection against such interference, when this type of equipment is used in a commercial environment. If there is interference to radio or TV reception, which is determined by switching it on and off. Relocate the equipment or use an electrical circuit other than the one used by the TRTC UPS.

# IMPORTANT SAFETY PRECAUTIONS

*Only qualified personnel should service or supervise the service of the TRTC UPS.*



**Danger:** Sealed lead-acid batteries with high energy and chemical hazards are used. This manual contains important operation and safety instructions.

## **TRTC UPS Safety System Checklist**

---

- Carefully unpack the TRTC UPS. Report any shipping damage **at once**.
- **Read this manual.** If you have any questions about safe installation, operations or maintenance of the system, contact Manufacturer's service department.
- **Before installation,** confirm that the voltage and current requirements of the load(s) are compatible with the system's output. Confirm that the line voltage and current is compatible with the system's input requirements.
- The system should be installed on a dedicated power circuit.
- Place a warning label on the enclosure indicating that an Uninterruptible Power Supply (UPS) is located inside, in case of an emergency.
- Use proper lifting techniques when moving system.
- The TRTC UPS has more than one live circuit. It is fed from AC as well as battery power. Power may be present at the output(s) even if the system is disconnected from line power.
- When installing a system in other than a Manufacturer cabinet, ensure that the environment meets the system specifications shown in Section 1.7, "Specifications" of this manual.

## **SAVE THIS MANUAL**

**It contains important installation and operating instructions. Keep it in a safe place.**

## Battery Safety Checklist

---



- High & **dangerous voltages** are present inside the system. Only qualified personnel should perform installation and maintenance.
- Live battery wires **must not** touch the TRTC UPS chassis or any other metal objects. **This can cause a fire or explosion.**
- **Inspect** the batteries once a year for signs of cracks, leaks, or swelling. Replace as needed.
- When batteries are in storage, **charge** them at least once every three months for optimum performance and to extend their lifetime.
- **Always** replace batteries with the ones of identical type and rating. **Never** install old or untested batteries. **Never** mix old with new batteries. **Never** mix the different amp hour rated batteries within one system.
- Use **insulated tools** during servicing.
- **Remove** all rings, watches, jewelry, or other conductive items before working inside the enclosure.
- **Follow** local regulations for the disposal of batteries. Recycling is the best method.
- **Never** burn batteries to dispose of them. **They may explode.**
- Do not open the batteries. **The contents are toxic.**

## Stand-By Generator

---



Note: If the TRTC UPS constantly switches between Battery and Line modes because of line fluctuations, the input parameters should be **broadened from Normal to Generator** (see Section 2.2.2 “Sense Type”)

In Generator mode, the acceptable range of input frequency and voltage is expanded to accommodate the voltage and frequency fluctuations created by a generator or a power source of such kind.

Use a generator with electronic speed and voltage controls which typically produces the Total Harmonic Distortion in % (THD) to be less than 10%. Generators with mechanical governors can force the system to run continuously in Battery mode.

Before installation, compare the generator’s output voltage to the TRTC UPS’s input voltage requirements as listed on both nameplates. To insure the system’s smooth operation, use a generator capable of supplying 2X or twice as much power as required by the total load.

## Unpacking and Inspection List

Carefully remove the TRTC UPS from its box. Inspect the contents and make sure the following items are included:

- One TRTC UPS System.
- One plastic bag containing the following:
  - Temperature sensor probe cable with 3-pin connector and extension cord.
  - Installation, Operations and Maintenance manual.

The Auto Transfer Switch (ATS) and all the associated wiring & hardware required for installation is supplied in a separate box.



Tip: If any items are missing or damaged, contact Manufacturer and the shipping company at once. Most shippers have a short claim period.

## SAVE THE ORIGINAL SHIPPING BOX

When returning the TRTC UPS for servicing, use the original shipping box with the supplied Styrofoam protectors. Manufacturer is not responsible for damage caused by improper packaging of returned systems.

## READ THE OPERATOR'S MANUAL

Before installation, become familiar with the TRTC UPS by reviewing the procedures and drawings in this manual. If you have any questions about safe installation, operation, or maintenance, contact Manufacturer customer service department.

## Complete the following for records & future servicing

<b>Model &amp; Serial # can be found on the nameplate label attached to the side of the unit</b>	
Model #	TRTC-
Serial #	
Products Sales Order #	
Purchase Order #	
Purchased from	
Telephone #	
Fax #	
E-Mail	
<b>The following details are for installation location</b>	
Installation date	
Installed by	
Street names	
City	
County / State	
Zip / Postal Code	
Country	



# Section 1: Installation & Start-Up

*Purpose: Describes the operation of the TRTC UPS System (Figure 1, 2 & 3).*

## 1.1.1 System Description

The TRTC UPS System provides backup power to traffic control signal equipment. It consists of the TRTC Uninterruptible Power Supply (UPS) System, the Auto Transfer Switch (ATS), and batteries that provide backup power when the line is unqualified. These three components can be mounted inside an enclosure to provide protection from most weather conditions.

Simplified TRTC 120V System Block Diagram

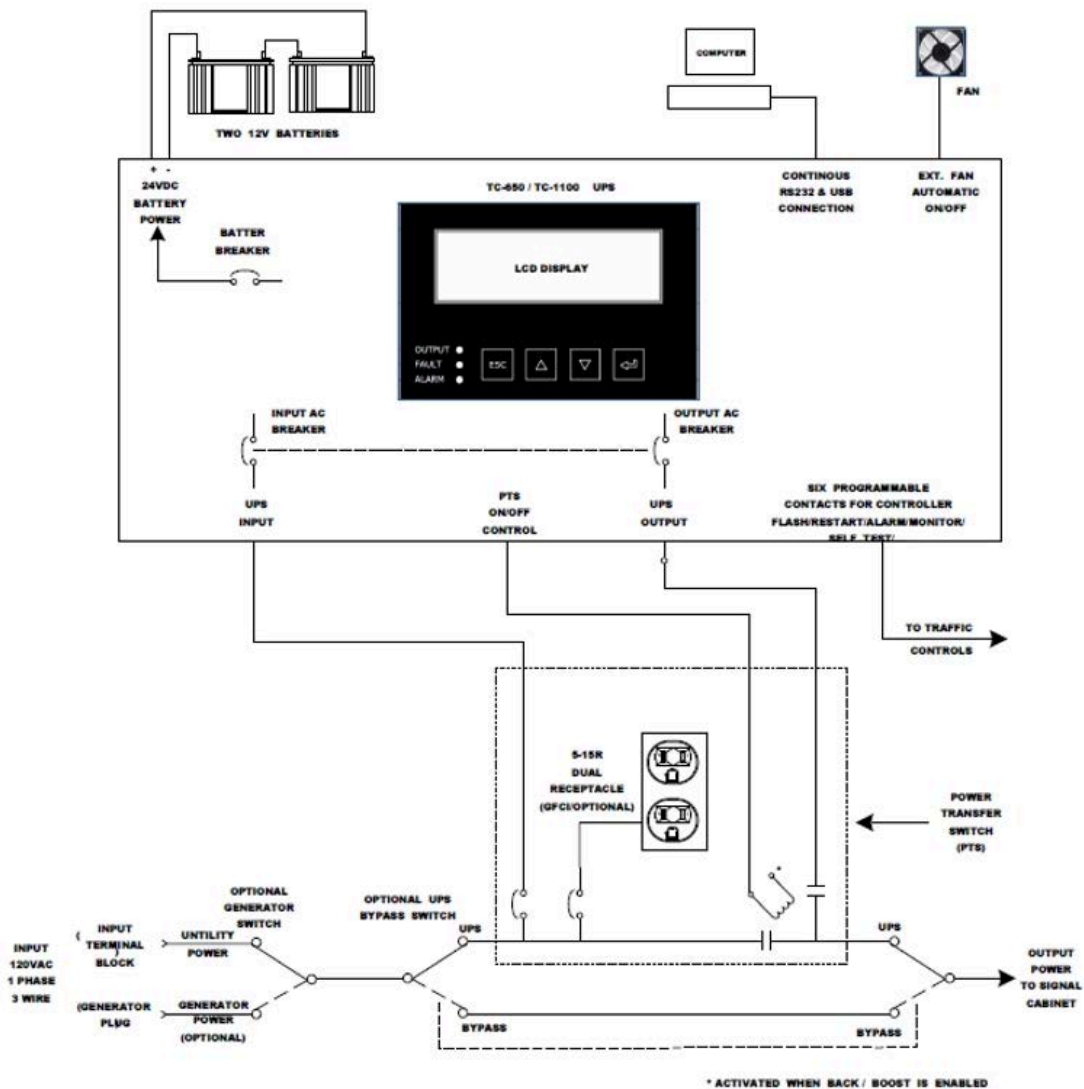

The traffic signal cabinet is powered continuously when a TRTC UPS system is installed. The system allows connection for the normal utility power (using standard terminal blocks or Anderson PP45 Quick connector or IEC Socket) or an optional generator power. The optional bypass switch redirects utility power to the load and allows the TRTC UPS to be removed for service on a temporary or permanent basis without disrupting the operation of the traffic signal.

With a fully functioning UPS system, the ATS allows utility power to flow out to the traffic cabinet, when the utility line is qualified (within the acceptable range as programmed). If the UPS is not functioning, the ATS will bypass the UPS allowing the utility to flow out to the traffic cabinet. The UPS input is protected with one circuit breaker located on the ATS as well as another one located on the UPS module. When the UPS internal BOOST and BUCK is enabled, the ATS is activated allowing UPS to continuously boost the output when input is lower, buck or lower the output when input is higher or run from batteries when input power is outside the specified acceptable range.

The smart, temperature compensated internal charger continuously monitors and maintains the batteries in a fully charged state. For the protection of the battery, the charging process is automatically discontinued when the battery temperature exceeds 50 degrees C. When input power is not qualified or is outside the acceptable range, the UPS derives the DC power from the storage tank of four batteries connected in series and maintains output power until the batteries are depleted down to a specified level or the utility power returns within its specified levels. The traffic intersection will continue to operate in full operation AND / OR in flash mode as programmed by the user. Programmable contacts allow the user to place the intersection in flash mode as soon as the input power is lost or after the batteries are depleted down to a certain capacity that is determined and programmed by the user. The amount of back-up time battery power can provide depends on the Amp-hour capacity of the batteries as well as the intersection watt load that requires support.

### 1.1.2 Front Panel Layout

The TRTC UPS System shown below provides control functions and backup power as described above. For more information, please see Section 2 of this manual.

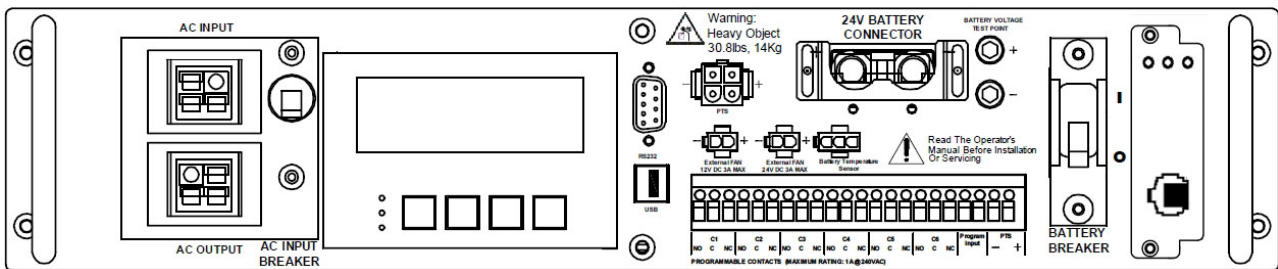

TRTC-0654-N1 and TRTC-1124-N1

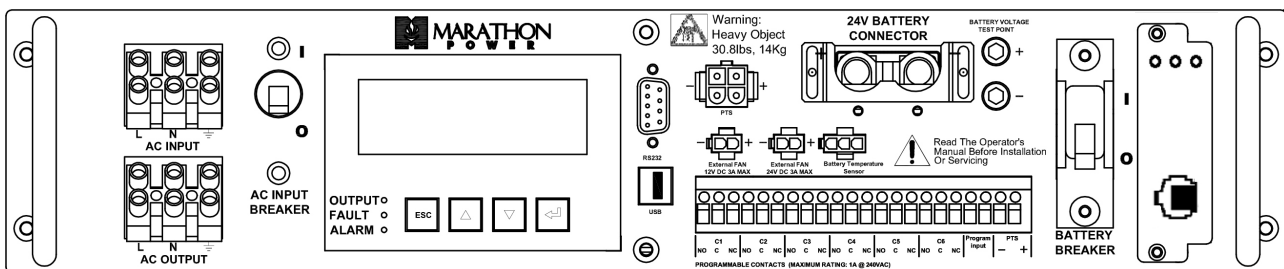

TRTC-0654-H2 and TRTC-1124-H2  
TRTC-0654-H1 and TRTC-1124-H1

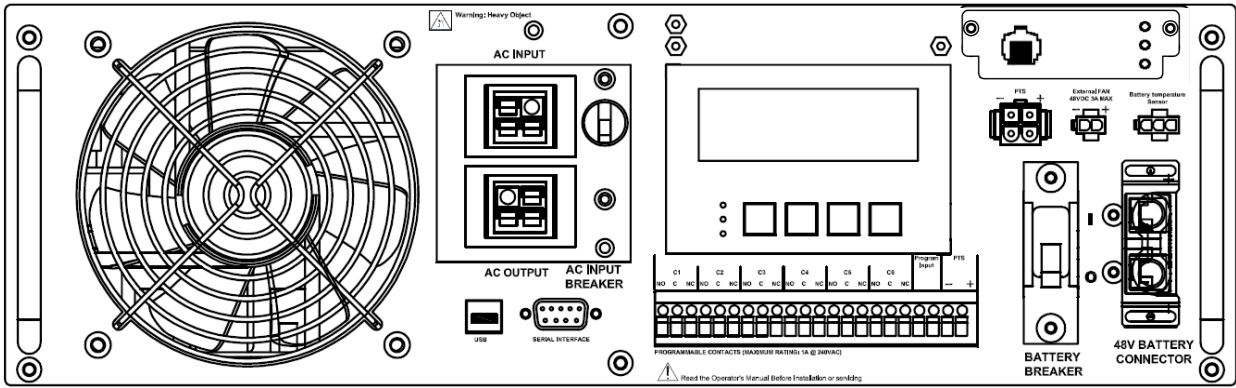

TRTC-2005-N1

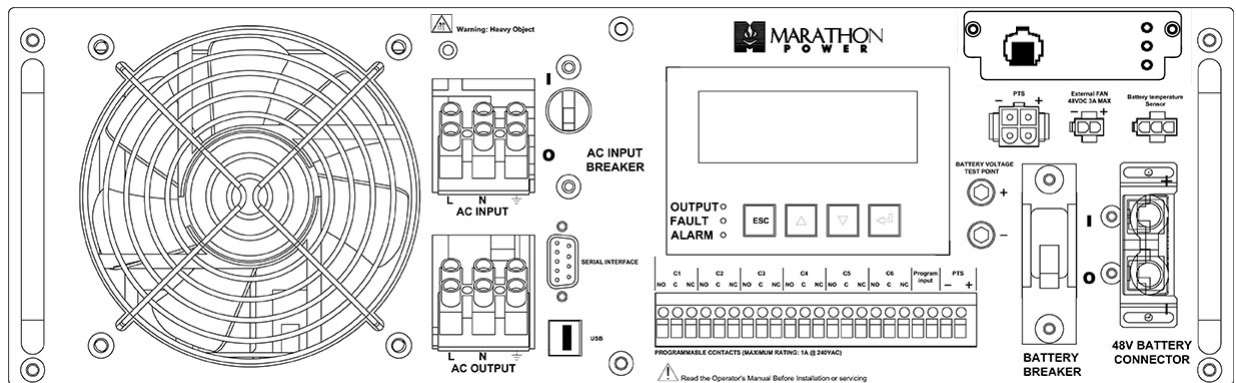

TRTC-2005-H1  
TRTC-2005-H2

### 1.1.3 Auto Transfer Switch

The Auto Transfer Switch (ATS) shown below allows the UPS to be removed for service, replacement or maintenance without interrupting power to the traffic cabinet.

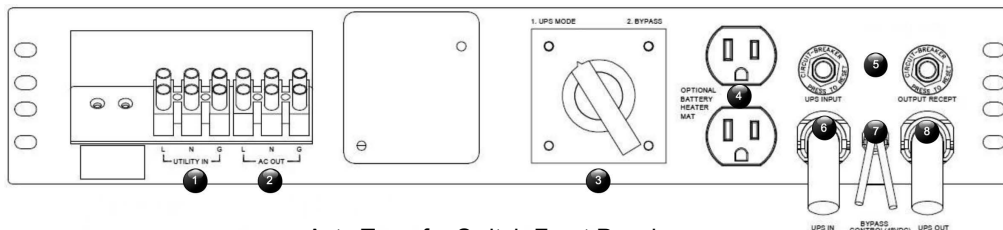

Auto Transfer Switch Front Panel

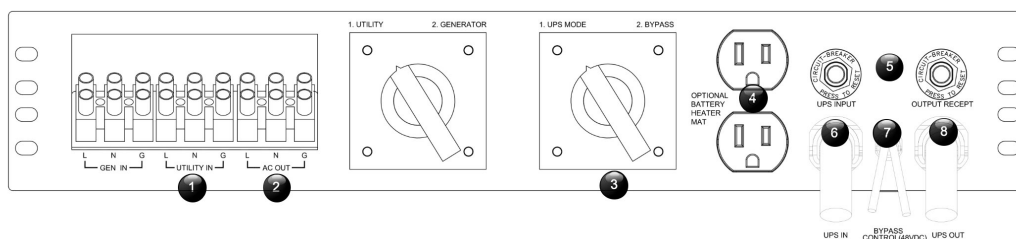

Auto Transfer Switch Front w/ Generator

1. Utility In
2. AC Out
3. Bypass/UPS switch allows the switching of the supply to the load between the incoming supply and the UPS, so the UPS can be isolated for maintenance.
4. Auxiliary output receptacle to optional battery heater mat.
5. UPS input and output circuit breaker.
6. UPS In
7. ATS Bypass control signal.
8. UPS out

## 1.1.4 Batteries

Different Amp-hour capacities or sizes of batteries can be used in the TRTC UPS system to provide various backup times. Two or Four batteries are connected in series for the required 24VDC or 48VDC. Contact customer service at Manufacturer for information on the battery best suited for your application. The battery harness supplied with the system is polarized and equipped with APP® SB50 type connectors. The battery harness provides a heavy-duty connection for each battery, so it is possible to unplug or hot swap them. Each of the four batteries may be connected in any order using the provided harness.

## 1.2 Mounting

**Purpose:** *Describes how to mount the TRTC UPS System into an enclosure.*

The TRTC UPS system components can be mounted into a single external cabinet or into an existing traffic cabinet.

### EXTERNAL MOUNT:

The factory supplied external cabinet can be bolted onto an existing or new traffic cabinet or this external cabinet can be pad mounted on a concrete slab or be pole mounted. The separate base for the cabinet for installation in the concrete slab, bolts & hardware for bolting onto the side of the traffic cabinet, bushing for the wire ducts, brackets for pole mounting and all the required accessories including mechanical hardware and electrical wiring are supplied to make the installation easy for the contractor. External cabinets such as BC100, BC80, etc. are outdoor type, weather proofed provided with internal exhaust fan that is temperature controlled, an intake filter that can be cleaned or replaced, a non-corrosive rubber mat for batteries, 3 point locking mechanism, lockable handle with dual keys and a unique internal keyed lock. The quality of cabinets bears a reputable industry trade name such as Manufacturer. The factory-supplied cabinet meets or exceeds the requirements of various NEMA classifications.

### INTERNAL MOUNT:

The TRTC components can also be mounted inside an existing NEMA or 332 or various other traffic cabinets. The special Swing Tray designed to hold the four batteries is easily mounted inside an existing 332 type or other equivalent cabinet using the hardware that is provided, or they can be shelf mounted in a NEMA or equivalent cabinet. The TRTC can be bolted into an industry standard 19" rack using the supplied ears or brackets, or it can be shelf mounted in a NEMA type enclosure. The ATS supplied with or without optional Generator & Bypass switch comes in many configurations that can be shelf mount, 19" rack mount, back plate mount, etc.

## 1.3 Wiring

**Purpose:** Describes how to wire the TRTC UPS System.



**Danger:** The utility input power line **must** have circuit breaker or fuse protection as per the local electrical code. It is referred as “Upstream Circuit Breaker” in this manual.

Before wiring the system, determine the size of the load:

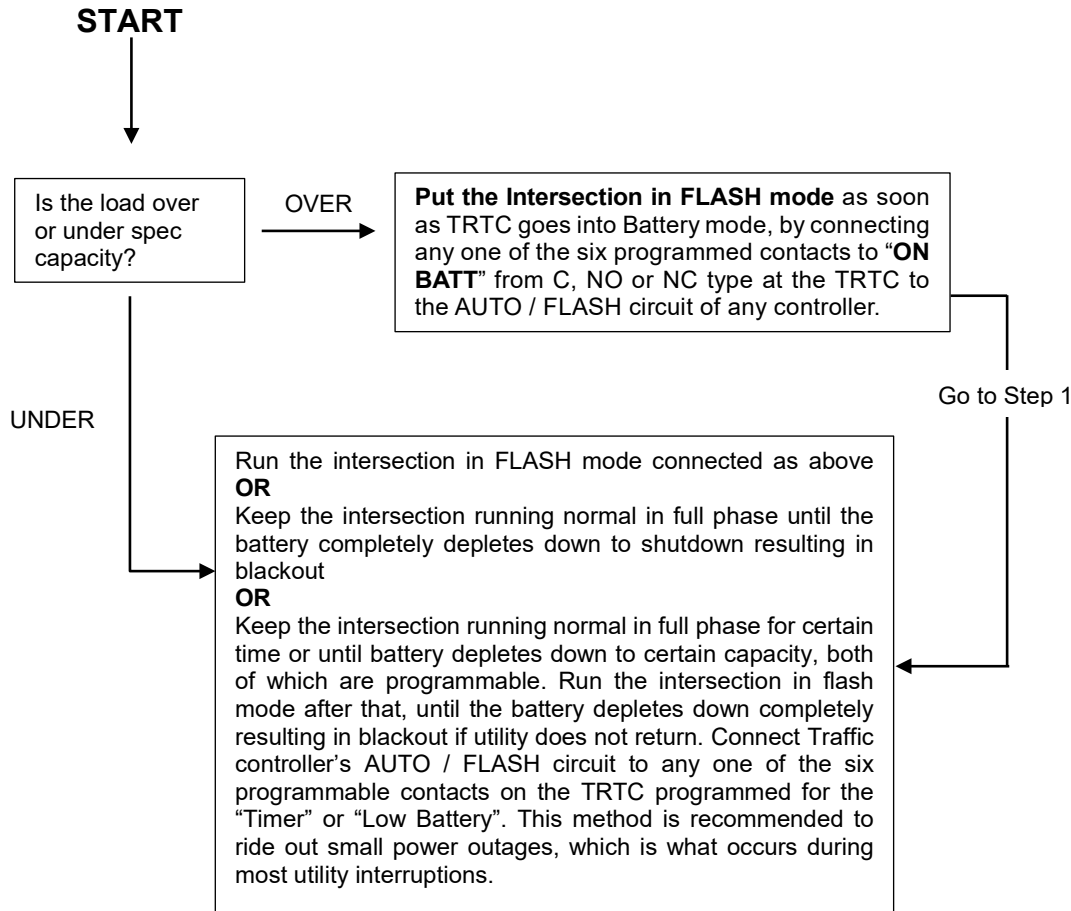

**TIP:** Each of the six contacts are of form C type, meaning Normally Open (NO), Common (C) and Normally Closed (NC) dry contact rated for 1 Amp at 240VAC. Each of these contacts can be individually programmed to energize and stay latched for ON BATTERY, LOW BATTERY, TIMER, ALARM, FAULT and many other conditions as described in subsequent chapters. The ON BATTERY contact/(s) are activated as soon as the TRTC UPS is transferred to Battery mode. LOW BATTERY contact/(s) are activated only in the Battery mode, as soon as the discharged battery reaches the lower value battery capacity as set by user and remains latched as long as the system remains in Battery mode. The TIMER contact/(s) are activated only in the Battery mode after the user-programmed time is attained, that can be set in 15 minutes interval from 15 minutes to 8 hours.

**TIP:** Verify that all breakers, AC and battery breakers are OFF prior to wiring.

## Step 1: Connect CONTROL wires

**START**

↓

Connect the **Battery Temperature Sensor** to the terminal of the middle battery, Plug the connector on the other end into the TRTC.

↓

Connect the **External Cabinet Fan** and the **RS232/USB Computer Cable** (if used).

↓

Connect the programmable contacts: **ON BATT, LOW BATT, TIMER** or **SELF TEST** contacts from TRTC to traffic cabinet for Flash mode (if used).

↓

**GO TO STEP 2**

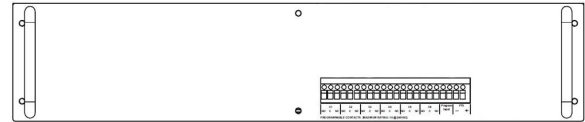
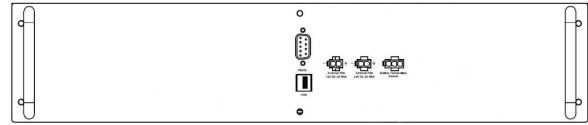

TRTC-1124-N1 Front Panel

TIP: Torque status/self-test terminal block to a maximum of 4.4 lb in (0.5 Nm). Maximum wire size is 14 AWG.

TIP: (See Section 2.1.2, Fig. 16) of this manual for details on the layout, operation, and specifications of the Control Terminal Block.

## Step 2: Connect ATS to the TRTC

**START**

↓

Connect the cord from UPS OUT at ATS to the **AC OUT** receptacle on TRTC.

↓

Connect the cord from UPS IN on ATS to **AC IN** receptacle on TRTC.

↓

Connect the cord from **Bypass control** on ATS to **PTS** on TRTC.

↓

**GO TO STEP 3**

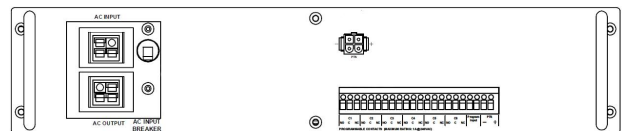

TRTC-1124-N1 Front Panel

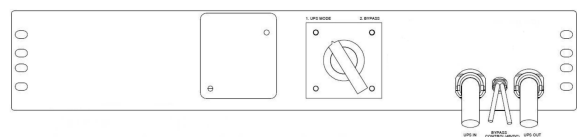

Power Transfer Switch

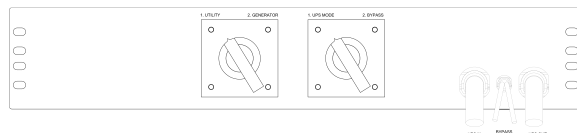

Power Transfer Switch with Generator

### Step 3: Connect the Input and Battery

**START**



Connect the supplied black wire from the input receptacle at ATS to the INPUT terminal in the signal cabinet.



Plug the Red **Battery** connector into the TRTC.



**UNIT IS READY FOR START UP**

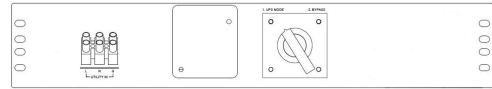

Power Transfer Switch

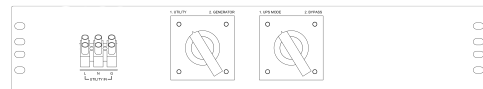

Power Transfer Switch with Generator



TRTC-1124-N1 Front Panel

## 1.4 Start-Up and Test

**Purpose:** Describes how to Start-up and test the system.

**TIP:** If the system does not perform as described below, see the troubleshooting section in Section 1.6 of this manual.

### Step 1: Turn on the Utility Input Line Power

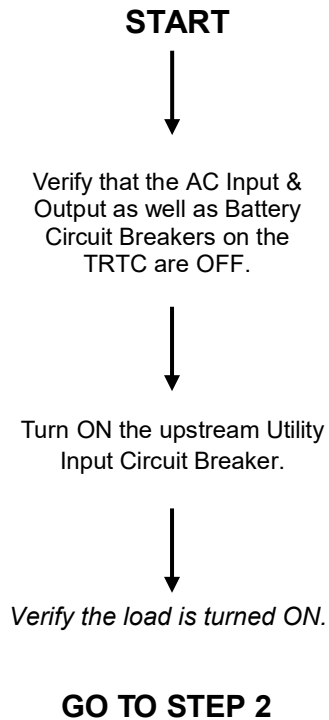

#### STARTUP PROCEDURE TIPS

The TRTC automatically starts up in Standby mode. After the AC line is qualified (default 30 seconds) the UPS switches to On Line mode. The ATS is a safeguard that the cabinet will always revert to utility power if there is ever a failure of the TRTC or batteries.

### Step 2: Turn on the UPS

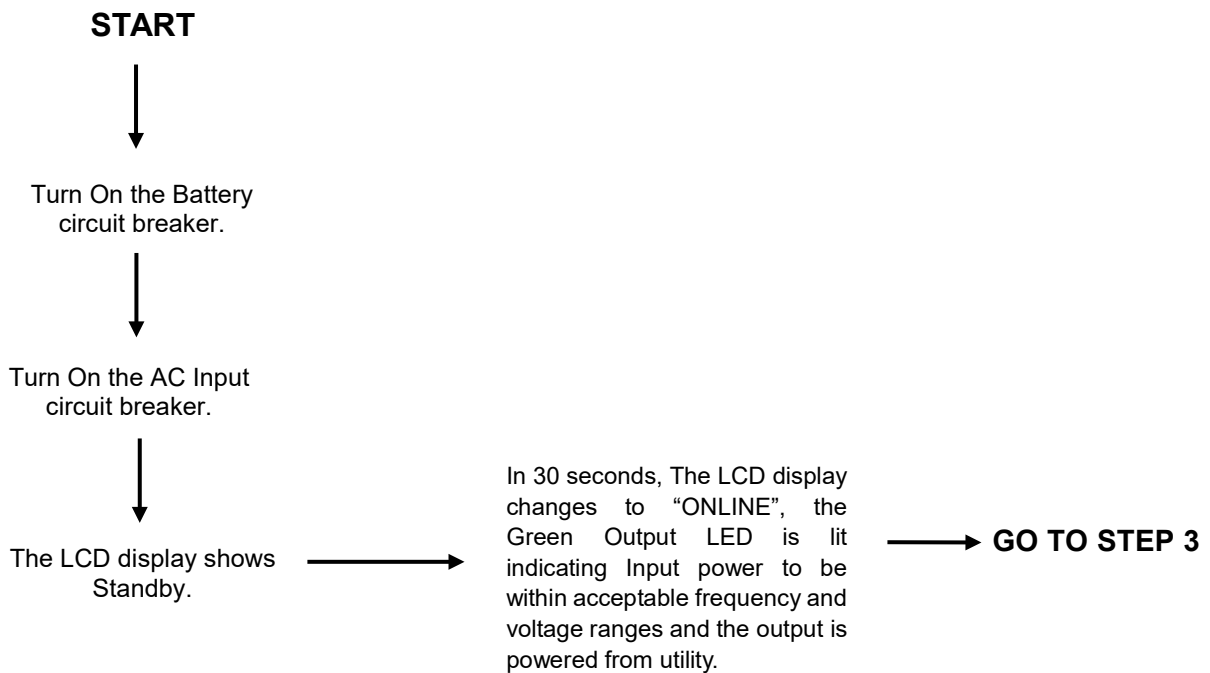



### Step 3: Test the system.

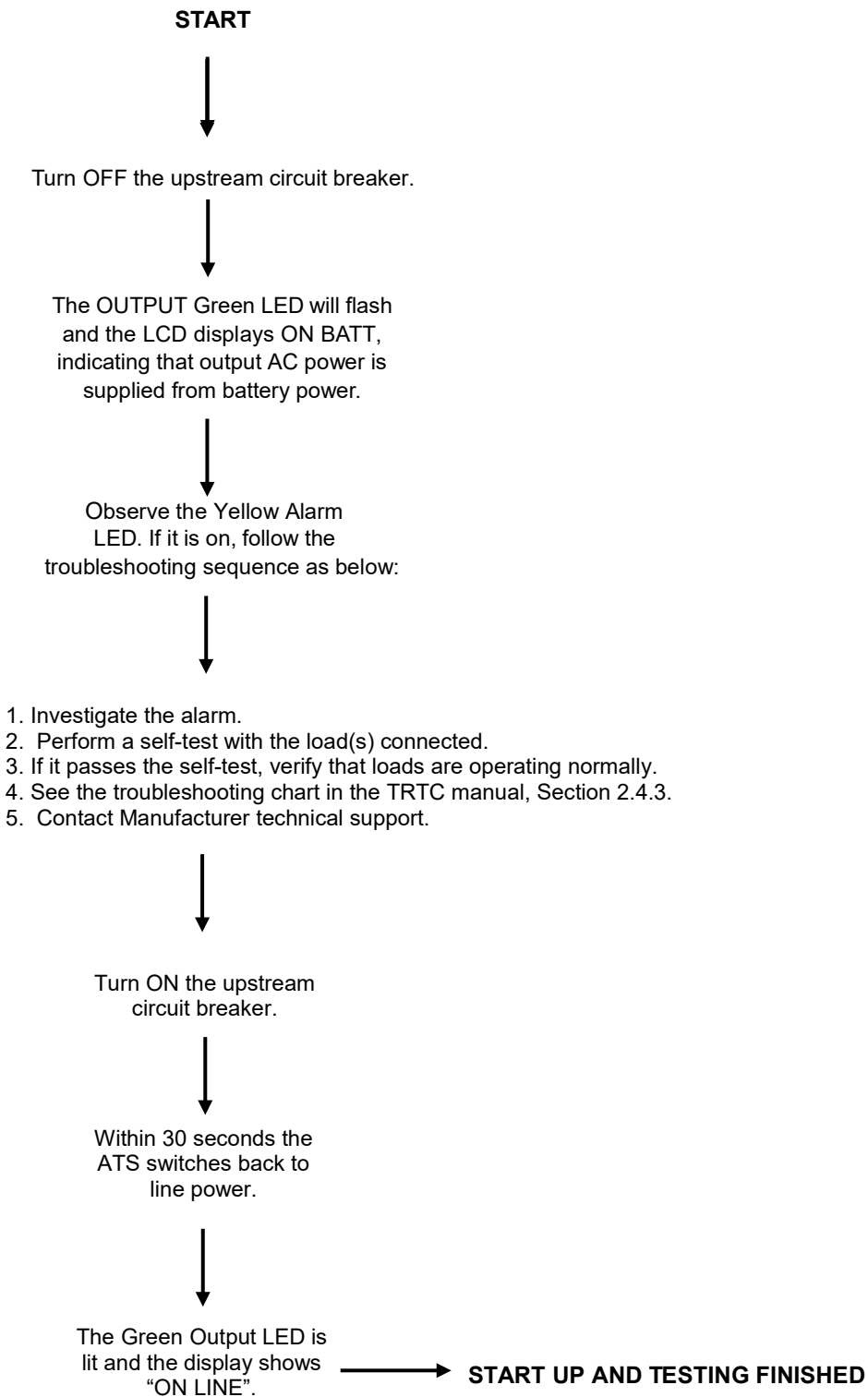

**TIP:** In ON LINE mode, press and hold "ESC" for 3 seconds to perform the self-test feature.

## 1.5 Shutdown

*Purpose: Describes how to shut down the system components for removal or maintenance.*

### 1.5.1 TRTC UPS

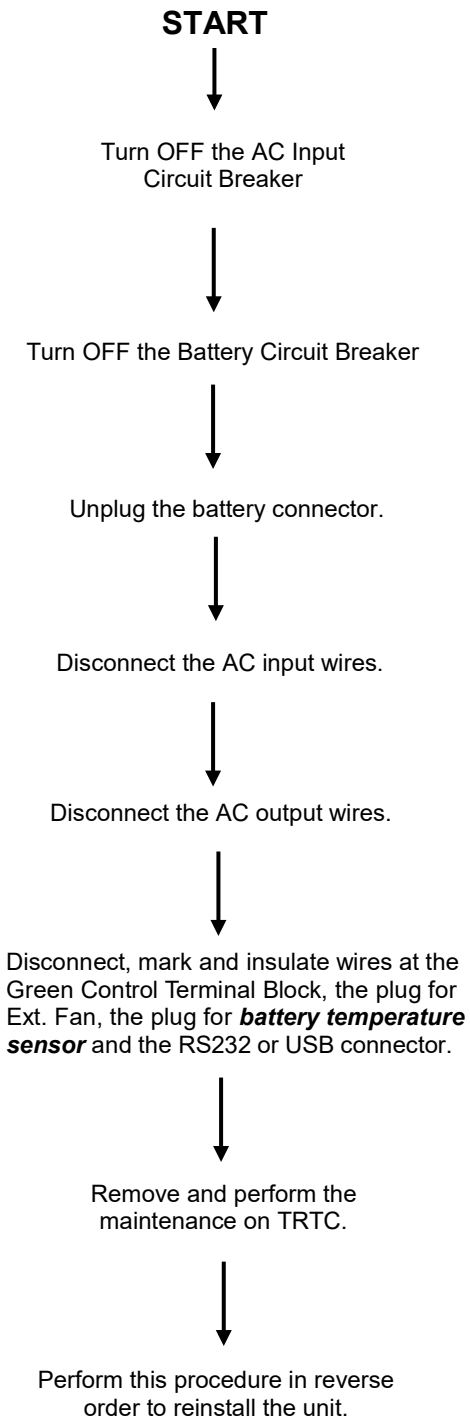

**Danger:** Shutting down the TRTC does not necessarily disconnect power to the loads.

**Danger:** The AC input wires from ATS are still **HOT** or **Live**. Insulate the bare wires using wire nuts.

**PROCEDURE FINISHED**

TIP: For additional information on how to operate the TRTC manual, (see Section 2.2).

## 1.5.2 ATS

**START**

Turn OFF the upstream  
circuit breaker

Disconnect the UPS OUT Cord

Disconnect the UPS IN cord

Disconnect the INPUT &  
OUTPUT cord

Remove and perform  
maintenance on the ATS

Perform this procedure in reverse  
order to reinstall the ATS

**PROCEDURE FINISHED**

**TIP:** Verify that both the AC and Battery  
Breaker are OFF at the TRTC.

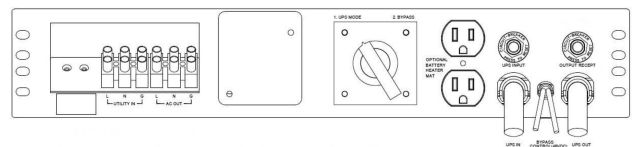

Power Transfer Switch

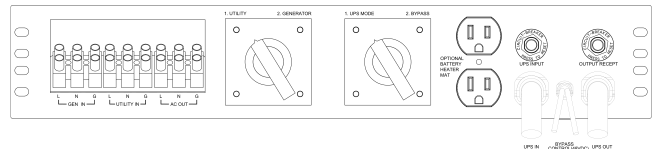

Power Transfer Switch with Generator

## 1.6 Troubleshooting

### TRTC System Troubleshooting Chart

SYMPTON	CAUSE	REMEDY
<b>No Output Available from ATS</b>	Upstream utility circuit breaker or fuse may be OPEN  Utility AC Power not available	CLOSE the upstream utility breaker or fuse  Check with the AC voltmeter & contact the Utility Company
	Wiring error	Correct wiring at ATS
	Faulty ATS	Replace the ATS
<b>ATS won't allow transfer to Battery mode</b>	TRTC output power not connected to ATS  "UPS OUTPUT" circuit breaker at ATS is open	Verify that "UPS OUT" cord is properly connected to the AC OUTPUT receptable at the TRTC  Reset the breaker and clear the fault
	Faulty ATS	Replace ATS
<b>TRTC does not return back to Input Line Mode</b>	Utility input line power is missing	Verify that "UPS IN" cord from the ATS is properly connected to the AC INPUT receptable at the TRTC.
		Verify that the "UPS INPUT" circuit breaker at the ATS is closed.
		Ensure that the utility input is present.

## 1.7 Emergency Shut Down Procedure

The TRTC is connected to more than one energy source. In an emergency, DISCONNECT utility input power, battery power, as well as an optional generator power, if utilized. Disconnecting all the AC and DC power sources will ensure that the output circuit is not live.

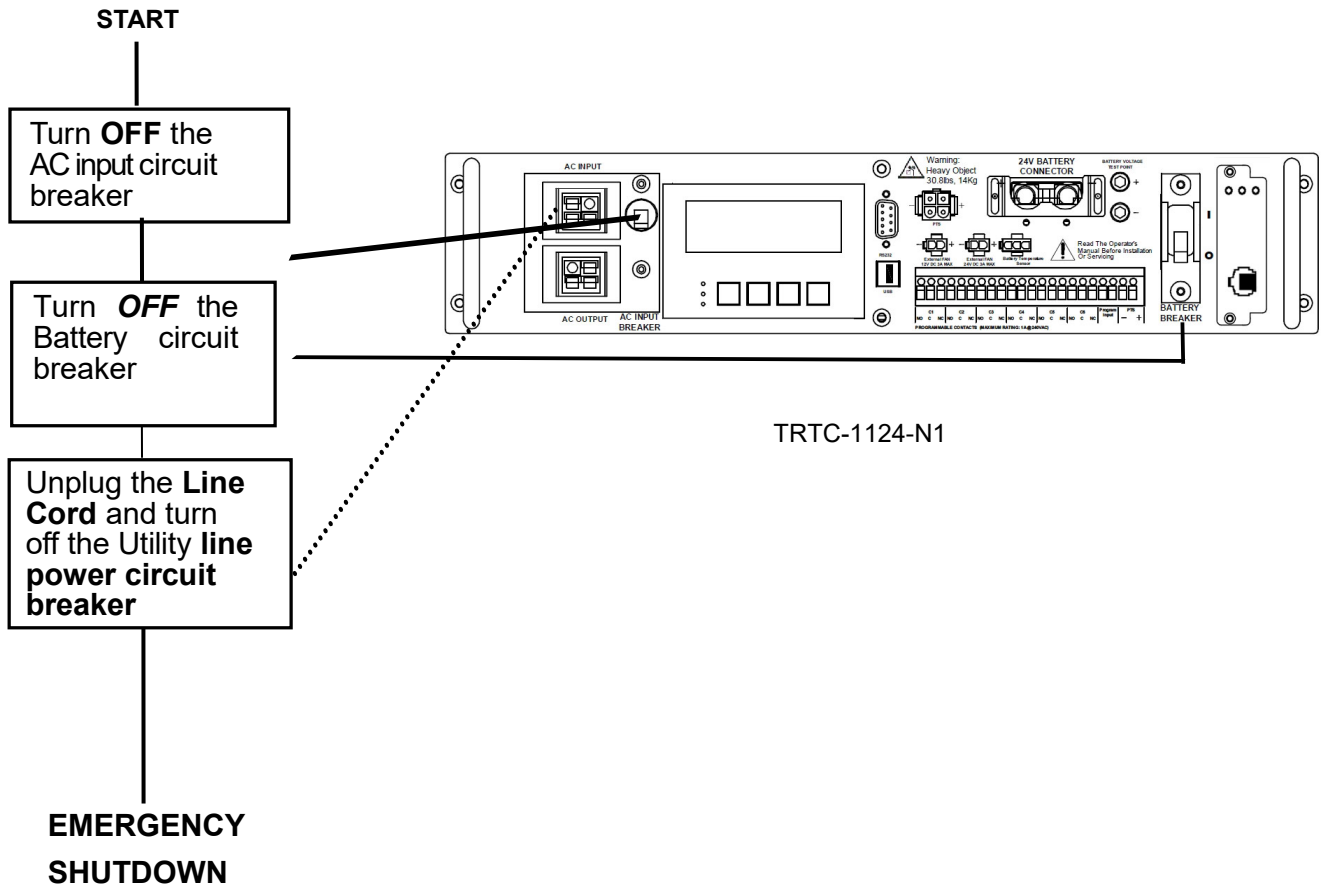

# Section 2 - Features

This section introduces the various features of the TRTC UPS System.

## 2.1.1 The Advantages Advanced Power Protection Technology

TRTC Series is an Uninterruptible Power Supply (UPS) also known as a Battery Backup System (BBS) designed for both indoor and outdoor applications. The TRTC provides continuous power to traffic and signal equipment.

### ◆ **Advanced Communications**

The RS232 and/or USB ports allow for local or remote monitoring of the TRTC Series.

### ◆ **Smart Charging**

TRTC Series smart charge technology ensures the batteries are always at peak performance.

### ◆ **User Friendly Supervision**

The LCD panel provides “At A Glance” monitoring and control.

### ◆ **Service Friendly**

The batteries can be changed without shutting down the intersection loads or the TRTC Series.

## 2.1.2 A Tour of the TRTC Series

*Purpose:* Describes the display, connections and switches on the TRTC Series front panel (Figures 12, 13 & 14).

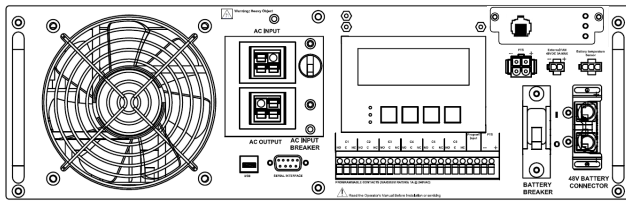

TRTC-2005-N1

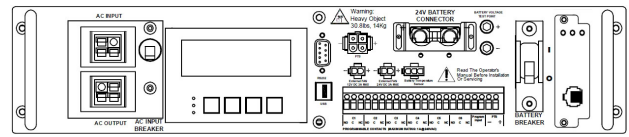

TRTC-1124-N1

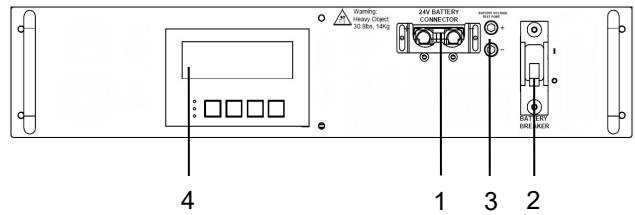
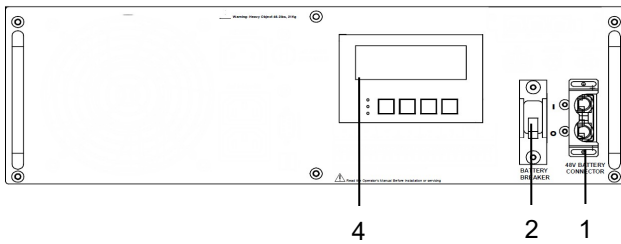

Figure 12

### 1. 24VDC/48VDC Battery Connector

Connects the battery to the unit. The battery string voltage is 24VDC/48VDC.

### 2. Battery Circuit Breaker

Acts as an ON/OFF switch for battery power. Must be in the **ON** position for normal operation.

### 3. Battery Voltage Test Points

Battery voltage can be measured at these Test Jacks only when the battery circuit breaker is turned **ON**.

**TIP:** TEST JACKS ARE NOT DC POWER OUTLET TERMINALS.

### 4. Liquid Crystal Display (LCD) Control Panel

The UPS can be controlled and monitored via this LCD panel. See Section 2.2 for further information.

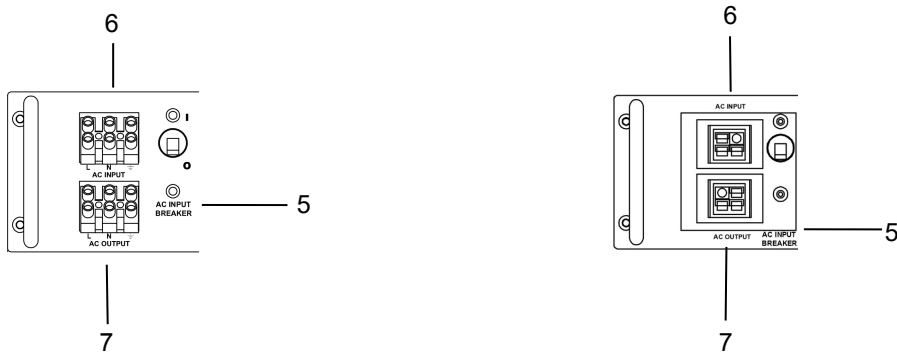

Figure 13

### 5. AC Input Circuit Breaker

Acts as a line power ON/OFF switch to facilitate the unit's maintenance or replacement. Must be in the **ON** position for normal operation.

### 6. AC Input

Inlet IEC-C14 Socket provided for the input of line power.

### 7. AC Output

Outlet IEC-C13 Socket provides the connection for the output of line power.

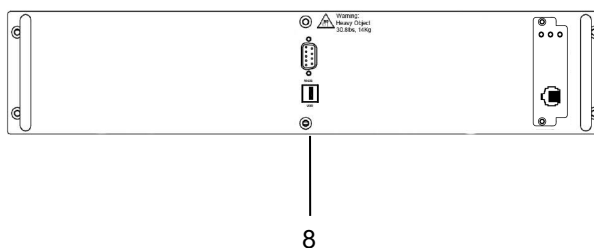

Figure 14

## 8. USB / Serial Interface / RS232 Connector

The USB and /or DB-9 female connector is used to connect the TRTC to the host computer for remote control, monitoring and calibration via RS232 commands.

For the USB or DB-9 female RS232 connections use computer industry standard computer cable between the computer's USB or RS232 port and the TRTC unit's USB or RS232 ports.

See Section 2.3 for more details about connection and use.

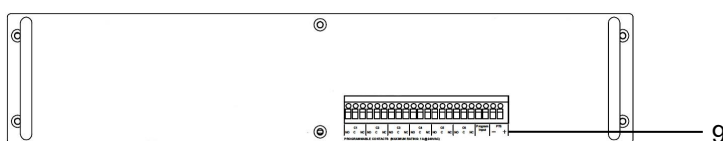



## 9. TRTC Series Dry Contact Terminal Block Details

The 22-position terminal block communicates with the intersection controller or other compatible equipment. In addition to the 6 standard dry contacts, there is a programmable Input contact and a contact for connecting to a Power Transfer Switch (PTS). The figure below shows the layout and operation.

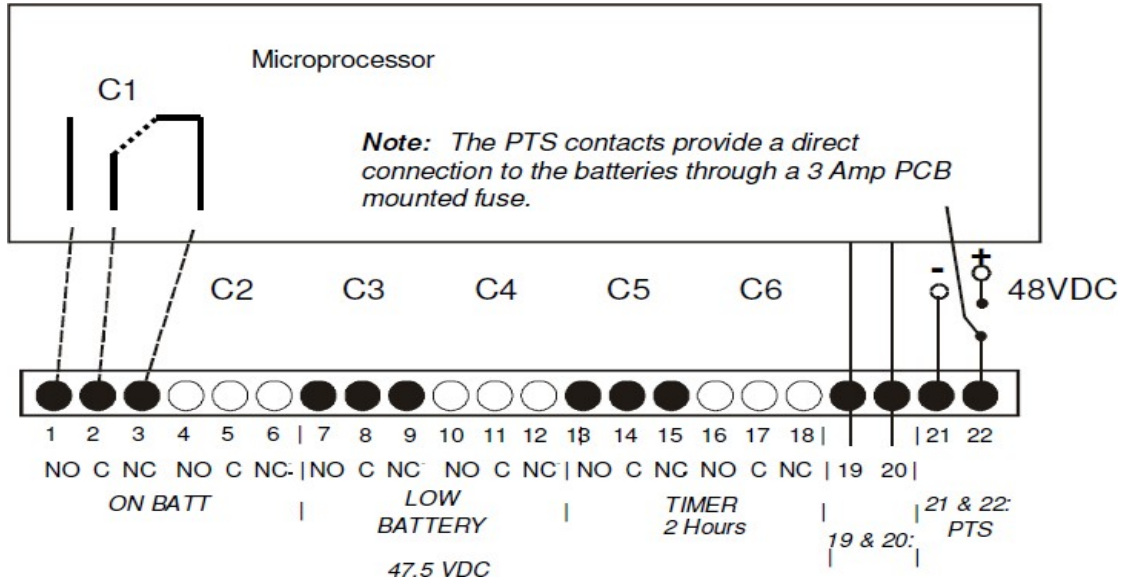

These contacts have a maximum rating of 1 Amp at 120V. Only the first On Batt contact is illustrated. The remaining five contacts for Low Battery, Timer, etc., are similar. The relay contacts are Form C type, i.e., each of the six programmable contacts has Common (C), Normally Closed (NC), and Normally Open (NO) contact position.

In normal UPS Mode, the NO contacts are open, and the NC contacts are closed.

When an event occurs, the NO Contacts become closed. The NC contacts become open.

These contacts do not do anything more than change a relay from normally open to closed or normally closed to open, opening or closing an electrical circuit when specific UPS events occur.

As an example, the UPS does not put an intersection to go into Flash Mode. A relay on the UPS changes states, and an electrical circuit is opened or closed. What happens to the intersection or load is entirely dependent on what circuit the wiring is connected to.

**The DEFAULT UPS Events that change the relays are,**

C1 - ON-Battery

C2 - On-Battery

C3 - Low Battery

C4 - Low Battery

C5 - 2-Hour Timer

C6 - 2-Hour Timer

The terminal block is opto-isolated and shares a common ground with the serial interface. Each of the six programmable contacts can be programmed individually for one function: On-Battery, Low Battery, Time, Alarm, Fault, or Disabled.

The **Programmable Input** can be labeled as a Self-Test, External Alarm, Ext. Battery Alarm, Ext. Fan Alarm, Door Interlock. Plus, the **Programmable Input** can provide Tip-over Protection, providing output lockout when a mercury tilt switch is connected.

- **On Batt:** This relay energizes when Utility Input line power is unqualified.
- **IMPORTANT:** When the AC input and output circuit breaker are open (OFF) an auxiliary switch of the circuit breaker opens, which disables the On Batt. contact at the Green Control Terminal Block. This prevents the intersection lights from flashing.
- **Low Battery:** The Low Battery relays energize when the battery drops below the programmed battery capacity. The default value is 47.5VDC for the 48V UPSs and 23.5V for the 24V UPSs.
- **Timer:** The Timer relays energize after the unit has been in Battery Mode for the programmed time. The factory default value is 2 hours. The time is adjustable from 15 min. to 8 hours in 15-minute increments.
- **Program Input:** The programmable input contacts, 19 & 20, can be programmed for one function, either Self-test, EXT Alarm, EXT Battery Alarm, EXT Fan Failure, Door Interlock, or Output Lockout
- **PTS:** Contacts 21 and 22 sends either a 48VDC or 24V DC signal from the batteries to the PTS, signaling that a UPS is connected to it.
- *Six sets of programmable contacts have the following factory default settings: C1, C2 = "On Batt." C3, C4 = "Low Batt @ 47.5VDC for the 48V UPSs and 23.5V for the 24V UPSs. C5,C6 = "Timer @2.00 Hours"*

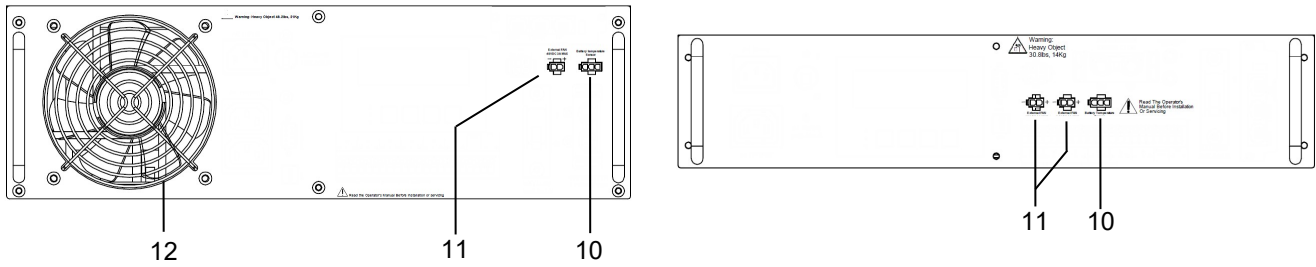

Figure 17

### 10. Battery Temp Sensor

It attaches the battery temperature probe to the unit for monitoring battery temperature. The charging voltage is temperature dependent. The microprocessor of the smart charger adjusts the voltage for optimum charging.

The temperature probe connector **must** be plugged in for normal operation. The sensor end should be firmly attached to the terminal of the battery.



**TIP:** If the UPS is not charging the batteries check the temperature probe. To test the temperature probe unplug it from the face of the UPS. Check the resistance of the temperature probe by inserting the probes of an ohm meter into the top and bottom pins of the connector. The meter should read approximately 10,000 Ohms at 25°C (77 °F). If resistance is not in this range, replace temperature probe.

### 11. Ext Fan 12VDC/24VDC or 48VDC

Provides DC Power (12VDC/24VDC or 48VDC, 1 Amp (Max)), which could be used to power an optional DC fan, mounted inside the enclosure for regulation of the interior temperature.

### 12. Internal Fan

This microprocessor-controlled fan regulates the unit's internal temperature. It must not be blocked.

# Section 2.2 Operation

This section describes how to start, shutdown and operate the UPS.

## 2.2.1 The LCD Panel

*Purpose: Describes the LCD display menus (Figure 18) and use of user-friendly sub-menus (Figure 19).*

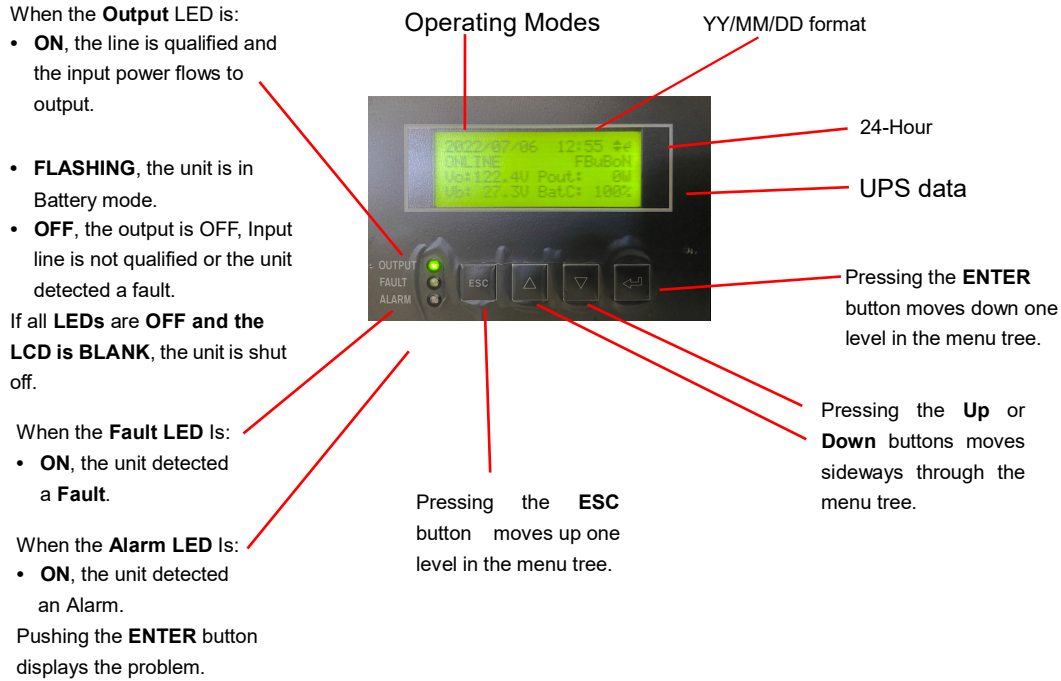

**Figure 19**  
LCD Panel Key Functions

**TIP:** When the ambient air temperature drops below -20°C (-4°F), the LCD may turn DARK until the temperature rises above -20°C (-4°F). However, the unit will operate normally.

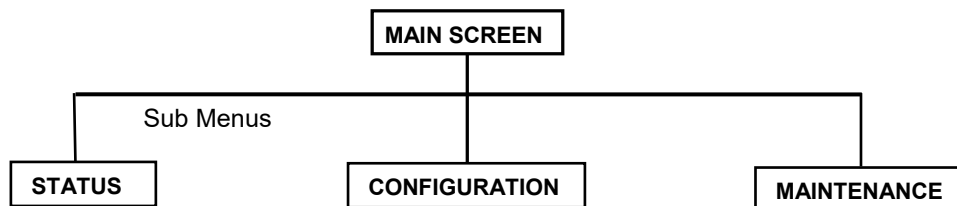

**TIP:** The complete menu tree is shown in Section 2.2.7, Figure 20.

## 2.2.2 TRTC Operating Modes

**Purpose:** Describes the Operating modes.

**TIP:** The LCD automatically displays the following modes when they change.

LCD Shows	Explanation
STANBY (STANDBY)	This mode is displayed when the unit is first turned on. The inverter remains off and the TRTC does not provide output power to the loads. If input line power is qualified, it automatically switches to line mode.
ONLINE	The normal operating mode. Input line power is provided to the loads, the batteries are charging and the TRTC is ready to provide backup power
ONBAT	The unit automatically transfers to battery when input line power is unqualified or not present. The batteries provide power to the loads
BOOST*	The unit automatically transfers to BOOST mode to raise the lower input line voltage when output drops below the user programmable preset limit
BUCK*	The unit automatically transfers to BUCK mode to reduce the higher input line voltage when output raises above the user programmable preset limit
SFTEST (SELF TEST)	When "Self-Test" mode is active, the unit will enter "Battery Mode" automatically to test or check if output voltage and waveform is correct. After the programmed duration, the unit returns back to "Line Mode". Users may use "Maintenance Mode" to configure a longer time for self-test. Default time for self-test is 1 minute.
LOWBAT (LOW BATT)	When the unit is in "Battery Mode" the batteries begins to discharge. If the battery voltage falls below the user programmed (40% default setting) of its capacity, "LOWBAT" warning appears.

\* When enable

The following mode may be programmed by the User (see Section 2.2.9)

### Sense Type (Generator / Normal Mode)

This is used to broaden the input parameters to accommodate the voltage fluctuations created by a backup generator or a noisy line.

The factory default setting is normal, where the unit runs on normal parameters. Switching to Generator makes it run on noisy generator parameters.

If the unit constantly switches between line and battery modes due to a noisy line, select generator mode to prevent unnecessary transfers / returns.

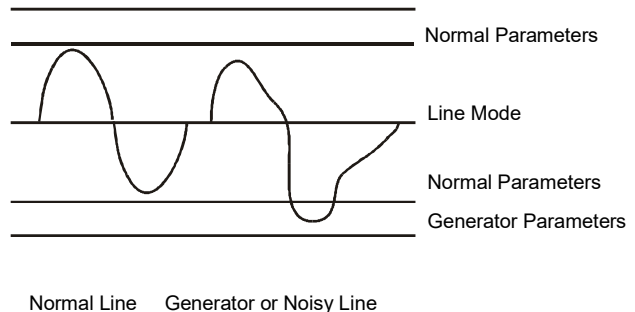

## 2.2.3 Self-Test

*Purpose: Describes the Self-Test.*



**Caution:** This procedure should not be performed when critical loads are running that depend on the unit for backup power. The Self-Test confirms that the unit can transfer into and out of Battery mode while supporting the output load at the same time.

### Procedure:

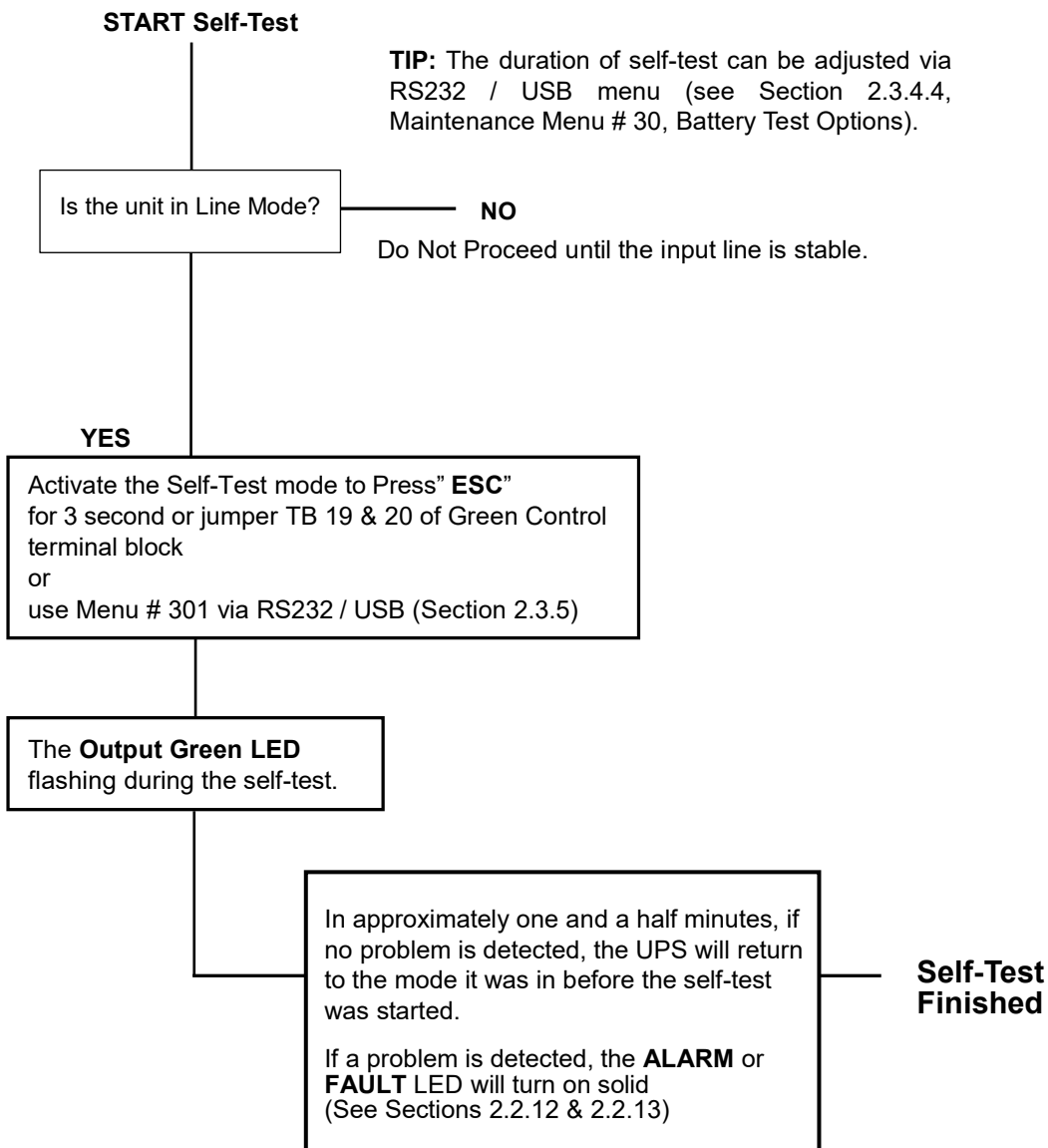

## 2.2.4 Start Up

*Purpose:* Describes the Start Up procedure.

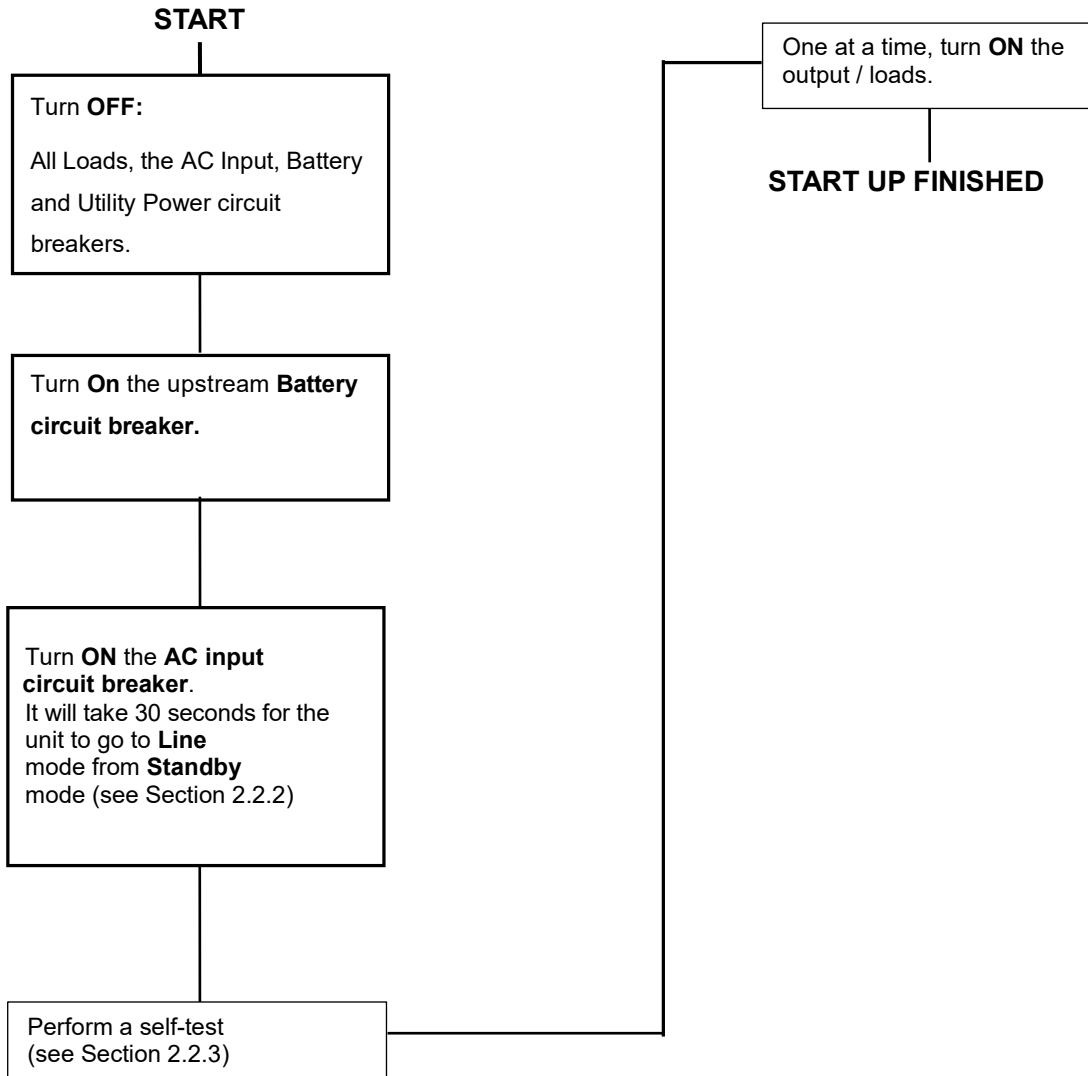

## 2.2.5 Shutdown

*Purpose:* Describes the shutdown procedure.

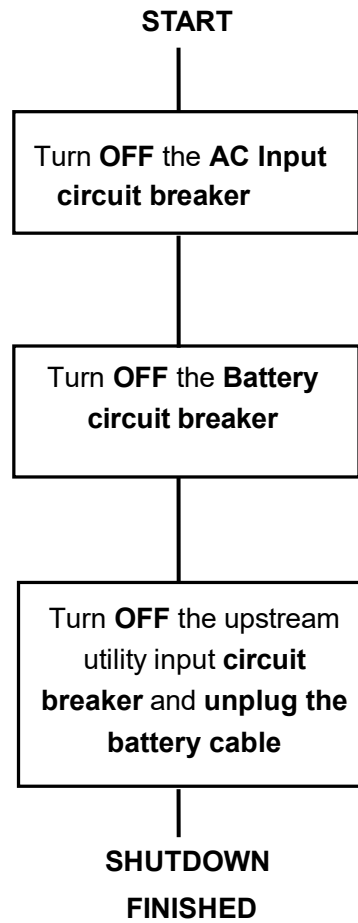



## 2.2.6 Battery Replacement

*Purpose:* Describes how to change the battery.



**Caution:** While the battery is being changed, the TRTC cannot provide backup power. This procedure should not be done while critical loads are running that depend upon the TRTC's backup power.

### BATTERY CHANGING PROCEDURE

**NOTE:** The **ALARM LED** remains **ON** during this procedure.

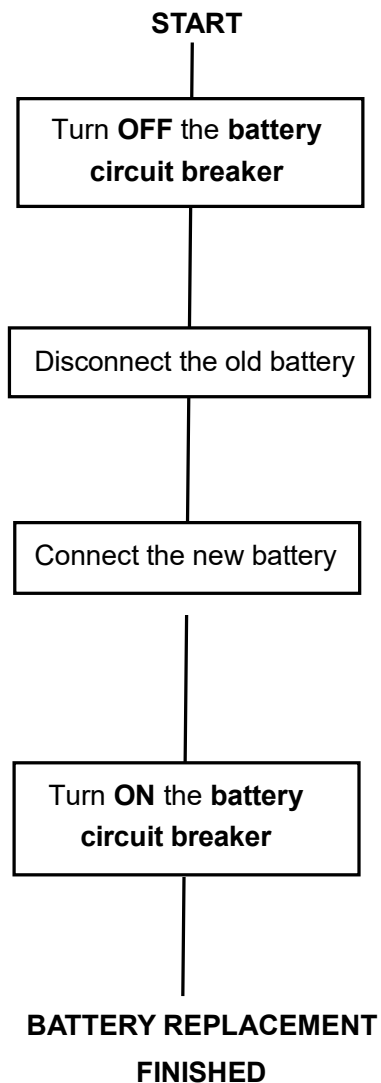

## 2.2.7 LCD Menu Tree and Main Screen

**Purpose:** Shows the Menu Tree (Figure 20).

**TIP:**

- The Alarm and Fault submenus alert the operator of a problem with the TRTC. When the alarm or fault LED is **ON**, press the **ENTER** button. One of the conditions described in Section 2.2.12 or 2.2.13 appears on the LCD screen.
- The status submenu provides measurements of important TRTC inputs, output, and other parameters via the LCD screen (Section 2.2.8).
- The configuration & maintenance submenu allows the operator to manage the TRTC (Section 2.2.9 & 2.2.10)
- To get the value of a specific measurement, when it appears on the LCD screen, press the **ENTER** button.
- To start a command, when it appears on the LCD screen, press the **UP** or **DOWN** or **ENTER** button.

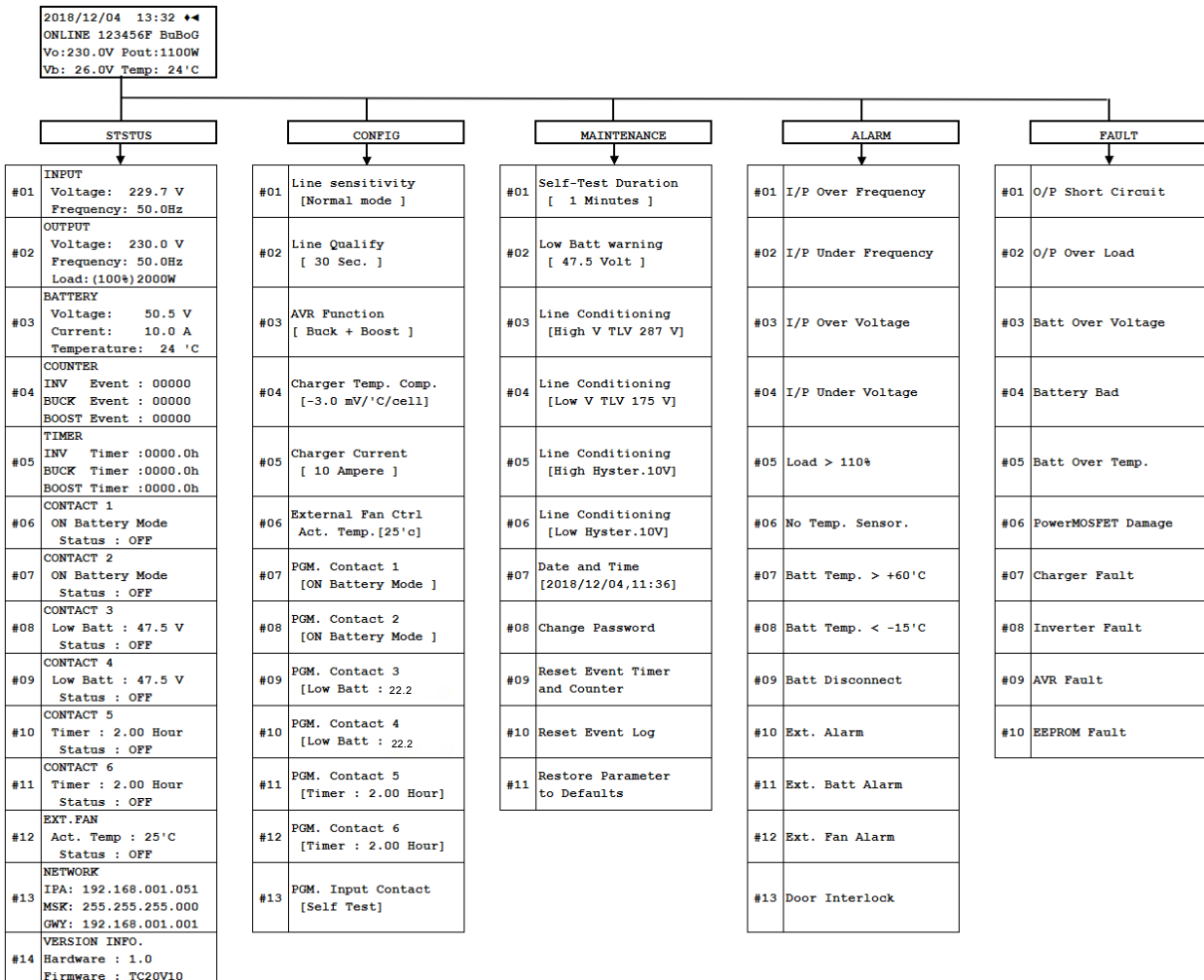

Figure 20

**Purpose:** Shows the Main screen.

ITEM	LCD SHOWS	DESCRIPTION
Main screen	2019/01/14 08:50 ◀◀ ONLINE 123456F BuBoG Vo: 120V Pout:2000W Vb: 27.4 Temp: 24'C	
Main screen Line 1	2019/01/14 08:50 ◀◀	Date & Timer
Main screen Line 2	ONLINE 123456F BuBoG	Status Contact status 123456 Ext Fan status F AVR setting Bu: Buck, Bo: Boost Sense Type setting N: Normal, G: Generator
Main screen Line 3	Vo: 120V Pout:2000W	The output voltage (true RMS) The output Power (watts)
Main screen Line 4	Vb: 27.4 Temp: 24'C	The average battery voltage The temperature of Battery case

## 2.2.8 Status Submenu

**Purpose:** Describes how to use the Status Submenu to measure the input and output parameters.

**Procedure:** On the main screen press **ENTER** to get to the status menu. After entering into STATUS menu, you can press **UP/DOWN** to view UPS status information.

ITEM	LCD SHOWS	DESCRIPTION
Page 1 Alarms	<b>A L A R M : E♦</b> No Temp. Sensor Batt Temp. < -15'C Batt Disconnect.	It indicates Alarms (see 2.2.12)
Page 2 Faults	<b>F A U L T : E♦</b> O/P Short Circuit. O/P Over Load. PowerMOSFET Damage.	It indicates Faults (see 2.2.13)
Page 3 Input Voltage Input Frequency	<b>I N P U T : E♦</b> Voltage: 119.7V Frequency: 50.0Hz	The Utility Input line voltage The Utility Input line frequency
Page 4 Output Voltage Output Frequency Output Power	<b>O U T P U T : E♦</b> Voltage: 120V Frequency: 50.0Hz Load: (100%)1100W	The output voltage (true RMS) The output frequency The output Power (watts)
Page 3 Battery Voltage Battery current Battery Temperature	<b>B A T T E R Y : E♦</b> Voltage: 27.4V Current: 10.0 A Temperature: 24 'C	The average battery voltage The battery current The temperature of Battery case
Page 4 Inv. Events Buck Events Boost Events	<b>C O U N T E R : E♦</b> INV Event : 00000 BUCK Event : 00000 BOOST Event : 00000	The number of times the unit has been in Battery Mode. The number of times the unit has been in Buck Mode. The number of times the unit has been in Boost Mode
Page 5 Inv. Timer Buck Timer Boost Timer	<b>T I N E R : E♦</b> INV Timer :0000.0h BUCK Timer :0000.0h BOOST Timer :0000.0h	The Total amount of time the unit has been in Battery Mode since the last reset. The Total amount of time the unit has been in Buck Mode since the last reset. The Total amount of time the unit has been in Boost Mode since the last reset. Each decimal indicates 6 minutes (0.1 x 6 minutes). The decimal increments by 2 or every 12 minutes.
Page 6 Program Contact 1 status	<b>C O N T A C T 1 E♦◀</b> ON Battery Mode Status : OFF press ◀ to test	The status of the program contact 1.

Page 7 Program Contact 2 status	<pre>C O N T A C T  2  E+◀ ON Battery Mode Status : OFF press ◀ to test</pre>	The status of the program contact 2.
Page 8 Program Contact 3 status	<pre>C O N T A C T  3  E+◀ Low Batt : 22.2V Status : OFF press ◀ to test</pre>	The status of the program contact 3.
Page 9 Program Contact 4 status	<pre>C O N T A C T  4  E+◀ Low Batt : 22.2V Status : OFF press ◀ to test</pre>	The status of the program contact 4.
Page 10 Program Contact 5 status	<pre>C O N T A C T  5  E+◀ Timer : 2.00 Hour Status : OFF press ◀ to test</pre>	The status of the program contact 5.
Page 11 Program Contact 6 status	<pre>C O N T A C T  6  E+◀ Timer : 2.00 Hour Status : OFF press ◀ to test</pre>	The status of the program contact 6.
Page 12 Ext. Fan temperature setting and status	<pre>E X T. F A N    E+◀ Act. Temp : 25 'C Status : OFF press ◀ to test</pre>	Indicates temperature setting and setting for external fan.
Page 13 Network settings	<pre>N E T W O R K :  E+ IPA: 192.168.001.051 MSK: 255.255.255.000 GWY: 192.168.001.001</pre>	The network setting for Network card.
Page 14 UPS Hardware version UPS Firmware version	<pre>V E R S I O N  I N F O . :  E+ Hardware : 1.0 Firmware :</pre>	The UPS hardware and firmware version list.

## 2.2.9 Config Submenu

**Purpose:** Describes how to access and program various critical parameters.

**Procedure:** On the main screen press **DOWN** to get to the Configuration menu. After entering the Configuration menu, you can press **UP/DOWN** button to select the UPS CONFIG you wish to execute:

FUNCTION	LCD SHOWS	ACTION
PROGRAM CONTACTS LINE SENSE TYPE	<pre> C O N F I G :   E+◀ Line Sensitivity [ Normal Mode ] E :Exit   ◀ :Change           </pre>	Toggle between Generator [Generator parameter] and Normal [Normal parameters]. This broadens the unit's input parameters to accommodate the fluctuations created by a generator or noisy line
LINE QUALITY	<pre> C O N F I G :   E+◀ Line Qualify Time [ 30 Sec. ] E :Exit   ◀ :Change           </pre>	Indicates the setting for AC recovery time. The selection options are: 3 sec, 10 sec, or 30 sec. Default recovery time is 30 sec.
AVR FUNCTION	<pre> C O N F I G :   E+◀ AVR Function [ Buck + Boost ] E :Exit   ◀ :Change           </pre>	Indicates the setting for AVR function. The selection options are: "Buck+Boost" / "Buck" / "Boost" / "Disable.
BATTERY TEMPERATURE COMPENSATION	<pre> C O N F I G :   E+◀ Charger Temp. Comp. [-3.0 mV/'C/cell] E :Exit   ◀ :Change           </pre>	This adjusts the battery charging temperature compensated voltage to -2.5 / -3 / -4 / or -5 mV/°C/Cell or disable temperature compensation. Consult the manufacture's specifications to find out which setting is best suited for your batteries. The factory default setting is -3 mV/°C /Cell.
CHARGING CURRENT	<pre> C O N F I G :   E+◀ Charging Current [ 10 Ampere ] E :Exit   ◀ :Change           </pre>	Indicates the setting for charging current. The default setting is 10Amps, and it can be settable range is 2~12Amps.
CHARGING VOLTAGE	<pre> C O N F I G :   E+◀ Charging Voltage [ 27.2 Volt ] E :Exit   ◀ :Change           </pre>	Indicates the setting for charging Voltage when temperature compensation is disabled. The TRTC-0654-N1 & TRTC-0654-N2, TRTC-1124-N1 & TRTC-1124-N2 24V system settable range is 27.2~29.3Volts. The TRTC-2005-N1 & TRTC-2005-N2 48V system settable range is 54.4~58.6Volt.
EXTERNAL FAN CONTROL	<pre> C O N F I G :   E+◀ External Fan Ctrl. Act. Temp. [ 25'C ] E :Exit   ◀ :Change           </pre>	Indicates temperature setting for external fan. The default setting is 25°C, and it can be settable range is 20°C ~ 55°C at 1°C increment.
PROGRAM CONTACT 1	<pre> C O N F I G :   E+◀ PGM. Contact 1 [ON Battery Mode ] E :Exit   ◀ :Change           </pre>	Indicates programmed values of contacts 1 and allows values to be changed.
PROGRAM CONTACT 2	<pre> C O N F I G :   E+◀ PGM. Contact 2 [ON Battery Mode ] E :Exit   ◀ :Change           </pre>	Indicates programmed values of contacts 2 and allows values to be changed.

PROGRAM CONTACT 3	<pre> C O N F I G :   E+◀   PGM. Contact 3 [Low Batt : 23.5 V ] E :Exit   ◀ :Change </pre>	Indicates programmed values of contacts 3 and allows values to be changed.
PROGRAM CONTACT 4	<pre> C O N F I G :   E+◀   PGM. Contact 4 [Low Batt : 23.5 V ] E :Exit   ◀ :Change </pre>	Indicates programmed values of contacts 4 and allows values to be changed.
PROGRAM CONTACT 5	<pre> C O N F I G :   E+◀   PGM. Contact 5 [Timer : 2.00 Hour ] E :Exit   ◀ :Change </pre>	Indicates programmed values of contacts 5 and allows values to be changed.
PROGRAM CONTACT 6	<pre> C O N F I G :   E+◀   PGM. Contact 6 [Timer : 2.00 Hour ] E :Exit   ◀ :Change </pre>	Indicates programmed values of contacts 6 and allows values to be changed.
PROGRAM INPUT CONTACT	<pre> C O N F I G :   E+◀   PGM. Input Contact [ Self Test ] E :Exit   ◀ :Change </pre>	Indicates programmed value of input contact and allow value to be changed. The selection options are: "Self-test" / "Ext. Alarm" / "Ext. BATT Alarm" / "Ext. FAN Alarm" / "Door Interlock".



## 2.2.10 Maintenance Menu

**Purpose:** Describes how to access, and view and modify various parameters for the maintenance.

**Procedure:** On the main screen press **UP** to get to the MAINTENANCE menu, then use **UP/DOWN** button to select the Functionality Menu, See below for details. When entering this menu you will need to enter password. The default password is 1111.

ONLY trained and qualified personnel normally use this menu, consequently the password protection option is provided to access this Menu.

FUNCTION	LCD SHOWS	ACTION
PASSWORD ACCESS	<pre> Pls enter password to continue : ????           </pre>	<p>It must be entered here before the Maintenance Menu can be accessed.</p> <p>Use the UP / DOWN arrow key with ENTER keys to enter a correct Password. Reentry is required if an error is made entering a Password.</p>
SELF-TEST DURATION OPTION	<pre> MAINTENANCE :  E+◀ Self-Test Duration [   1 Minutes ] E :Exit  ◀ :Change           </pre>	<p>Self-Test duration Option can be verified here. Self-Test period of 1 to 255 minutes can be selected here in 1 minute increments.</p>
LOW BATTERY WARNING OPTION	<pre> MAINTENANCE :  E+◀ Low Batt Warning [   22.7 Volt ] E :Exit  ◀ :Change           </pre>	<p>The low battery warning setting function. The default low battery warning voltage is: 23.5VDC/47.5VDC (The TRTC-0654-N1 &amp; TRTC-0654-N2, TRTC-1124-N1 &amp; TRTC-1124-N2 settable Battery Voltage range is 21.0VDC~27.5VDC at 0.5VDC increments.) (The TRTC-2005-N1 &amp; TRTC-2005-N2 settable Battery Voltage range is 42.0VDC~55.0VDC at 0.5VDC increments.)</p>
LOW BATTERY SHUTDOWN OPTION	<pre> MAINTENANCE :  E+◀ Low Batt Shutdown [   22.2 Volt ] ◄:Variable ◀:Confirm           </pre>	<p>The low battery shutdown setting function. The default low battery warning voltage is: 21.0VDC/42.0VDC (The TRTC-0654-N1 &amp; TRTC-0654-N2, TRTC-1124-N1 &amp; TRTC-1124-N2 settable Battery Voltage range is 18.00VDC~21.75VDC at 0.25VDC increments.) (The TRTC-2005-N1 &amp; TRTC-2005-N2 settable Battery Voltage range is 36.0VDC~42.0VDC at 0.5VDC increments.)</p>
LINE CONDITIONING HIGH VOLTAGE THRESHOLD LIMIT VALUE	<pre> MAINTENANCE :  E+◀ Line Conditioning [ High V TLV 287 V ] E :Exit  ◀ :Change           </pre>	<p>It indicates Programmed values of input utility line exceeds this voltage setting the TRTC will transfer to Battery Mode from Line Mode or Buck Mode.</p>
LINE CONDITIONING LOW VOLTAGE THRESHOLD LIMIT VALUE	<pre> MAINTENANCE :  E+◀ Line Conditioning [ Low V TLV 175 V ] E :Exit  ◀ :Change           </pre>	<p>It indicates Programmed values of input utility line drops below this voltage setting the TRTC will transfer to Battery Mode from Line Mode or Boost Mode.</p>
LINE CONDITIONING HIGH HYSTERESIS	<pre> MAINTENANCE :  E+◀ Line Conditioning [ High Hyster.10 V ] E :Exit  ◀ :Change           </pre>	<p>It indicates Programmed values of High hysteresis that is used to transfer to Line mode or Buck Mode from Battery Mode. The high hysteresis value is also used to transfer to Line Mode from Buck mode.</p>
LINE CONDITIONING LOW HYSTERESIS	<pre> MAINTENANCE :  E+◀ Line Conditioning [ Low Hyster.10 V ] E :Exit  ◀ :Change           </pre>	<p>It indicates Programmed values of Low hysteresis that is used to transfer to Line mode or Boost Mode from Battery Mode. The low hysteresis value is also used to transfer to Line Mode from Boost mode.</p>



SET DATE/TIME	<pre> MAINTENANCE :    E+◀   Date and Time  [ 2018/12/04,11:36 ] E :Exit    ◀ :Change </pre>	<p>It indicates current date and time. The display of the item to be set will be flashing. In sequence of Year, Month, Date, Hour, Minute, use UP/DOWN to adjust, then press "Enter" to confirm. The format of Date is 20yy/mm/dd. The period can be displayed is from Year 2016 to Year 2099 (i.e., from 2016/01/01 to 2099/12/31). The time is in 24 hours format (i.e., hh:mm) °</p>
CHANGE PASSWORD	<pre> MAINTENANCE :    E+◀   Change Password ? E : No/Exit ◀ : Yes </pre>	<p>The Password for the access of the Maintenance Menu is changed here. Use the UP / DOWN arrow key with ENTER keys to enter a correct Password. Reentry is required if an error is made entering a Password.</p>
EVENTS/TIMER RESET	<pre> MAINTENANCE :    E+◀   Reset Event Timer   and Counter ? E : No/Exit ◀ : Yes </pre>	<p>This resets the event timer and counters. After pressing the enter, the inverter, buck and boost events timer and counter will be clear and reset to zero.</p>
LOG RESET	<pre> MAINTENANCE :    E+◀   Reset Event Log ? E : No/Exit ◀ : Yes </pre>	<p>This clears all the messages from the Event Log.</p>
RESTORE PARAMETER TO DEFAULTS	<pre> MAINTENANCE :    E+◀   Restore Parameter   to Defaults ? E : No/Exit ◀ : Yes </pre>	<p>This restore the parameter to the default, the parameter like Transfer point, Line qualify time, Programmable contacts will be reset to default value.</p>

### 2.2.11 Alarm Menu

**Purpose:** Describes the Alarm Submenu and how to use the LCD for troubleshooting. (Figures 21, 22 and 23)

**Procedure:** When the **Yellow ALARM LED** is **ON**, the unit has an alarm, indicating a condition not serious enough to stop it from providing output power. Press **ENTER** to see the alarm.



1. Yellow Alarm LED ON

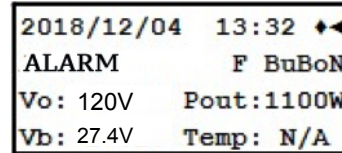

2. Unit has ALARM condition

**Figure 21**  
LED Shows an Alarm

**Figure 22**  
LCD Displays the Alarm

LCD SHOWS	Alarm	DESCRIPTION
I/P Over Frequency	Line Frequency	The Input frequency is fluctuating & out of tolerance.
I/P Under Frequency		
I/P Over Voltage	Line Voltage	The Input voltage is fluctuating & out of tolerance.
I/P Under Voltage		
Load > 110%	Overload	The loads are drawing more power from the TRTC than it can provide.
No Temp. Sensor.	Temperature Probe Unplugged	The battery temperature probe is unplugged or damaged. When the unit detects the probe is unplugged, it will continue to operate but the charger voltage will automatically be set to the lowest value.
Batt Temp. > +60°C	Battery High Temperature	The Battery temperature is high.
Batt Temp. < -15°C	Battery Low Temperature	The Battery temperature is low.
Batt Disconnect	Battery Not Connect	The Battery is not connected.
Ext. Alarm	External Alarm	The external alarm of the program input contact.
Ext. Batt Alarm	External Battery Alarm	The external battery alarm of the program input contact.
Ext. Fan Fail	External Fan Fail	The external fan failure of the program input contact.
Door Interlock	Door Interlock	The door interlock of the program input contact.

Note: The alarms are self-resettable. After the alarm condition is removed, the unit automatically returns to Line mode if the line is qualified, or battery mode if the line is unqualified.

**Figure 23**

Alarm Table

## 2.2.12 Fault Menu

**Purpose:** Describes the Fault Submenu and how to use the LCD for troubleshooting. (Figures 24, 25 and 26)

**Procedure:** When the **RED FAULT LED is continuously ON**, the unit has a fault, indicating a condition where backup power is unavailable. Press **ENTER** to display fault description.

**TIP:** When the unit has a fault and line power is qualified and available, the output loads are directly connected to the Input line with no line conditioning or backup power provided.



1. Red Fault LED on

**Figure 24**

LED Shows a Fault

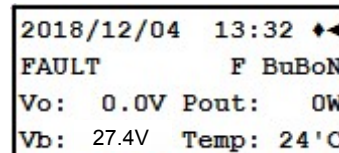

2. Unit has FAULT

**Figure 25**

LCD Displays Fault

<b>LCD SHOWS</b>	<b>Fault</b>	<b>DESCRIPTION</b>
O/P Short Circuit	Output Short Circuit	The load is short-circuited or the inverter did not start.
O/P Over Load	Overload	The loads are drawing more power than the TRTC can provide.
Batt Over Voltage	High Battery Voltage	The batteries voltage is high.
Battery Bad	Battery Bad	The batteries are bad.
Batt Over Temp.	Battery High Temperature	The batteries temperature is too high, It's over 50°C.
Power MOSFET Damage	Power MOSFET Damage	The Power board MOSFET is damage and inverter did not work.
Charger Fault	Charger function Fault	The charger voltage or current is over specification.
Inverter Fault	Inverter function Fault	The UPS inverter did not work.
AVR Fault	AVR function Fault	The AVR (Buck or Boost) function did not work.
EEPROM Fault	EEPROM Fault	The EEPROM is fault.

**Figure 26**

Fault Table

## 2.2.13 Low Battery Mode Status

**Purpose:** Describes the various states of the Low Battery Mode (Figure 27).

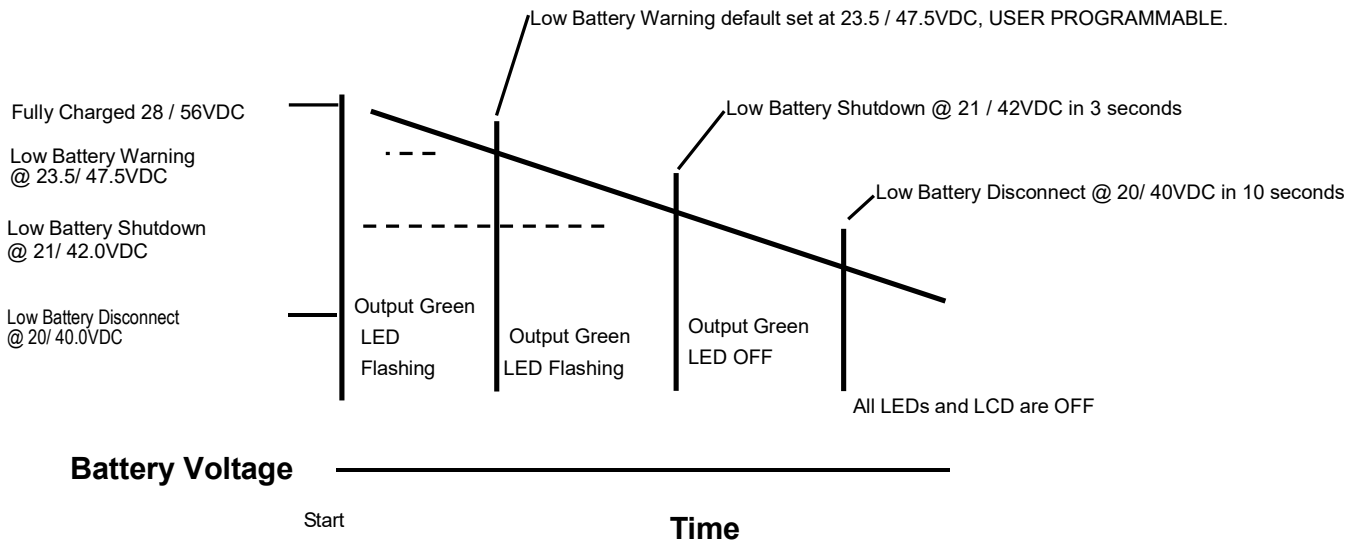

\* TRTC-0654-N1/H2, TRTC-1124-N1/H2: 24VDC  
 \* TRTC-2005-N1/H2: 48VDC

**Figure 27**  
 Low Battery Modes Status

**Note:** Not to scale. All values are shown for illustrative purpose **only** and will **charge under different operating and battery conditions**. Actual times will be different. Perform a run time test (Section 2.4.1) for application specific operating conditions.

### Low Battery Warning

The batteries will continue to power the load, but they are almost discharged and cannot provide power much longer.

**TIP:** The operator should shut down unnecessary loads to extend battery backup time.

### Low Battery Shutdown

When the battery decreases to (TRTC-0654-N1/H2, TRTC-1124-N1/H2) 21.0VDC / (TRTC-2005-N1/H2) 42.0VDC for 3 seconds, the unit automatically shuts output OFF and goes into STANDBY mode waiting for input power to return. The batteries are considered fully discharged and can no longer support the load, but they have enough power to keep the unit's monitoring and control circuits active. The housekeeping power supply is kept alive.

### Low Battery Disconnect

When the battery discharges to (TRTC-0654-N1/H2, TRTC-1124-N1/H2) 20VDC / (TRTC-2005-N1/H2) 40VDC for 10 seconds, the unit automatically goes into this mode. The batteries are disconnected from the unit to protect the batteries from being damaged by a deep discharge. Both the LED and LCD shut OFF, showing the unit is shut off. The unit stays off until line power or a backup generator is available or fresh batteries are connected. To prevent battery damage, if the TRTC is to remain in a low battery disconnect state for an extended period. The TRTC and battery circuit breakers **must be** switched OFF and the manual bypass switch **must be** switched to the Bypass position. For additional protection disconnect the Anderson style battery connector from the TRTC.



Note: Only authorized personnel should perform all parameter changes, as it may affect the performance of the traffic intersection.

## 2.3.1 RS232/USB Set-Up

**Purpose:** Describes how to set-up communication between any PC and the UPS using the RS232 or USB port. The TRTC Series uses a standard DB-9, RS232 cable or USB cable.

When the DB-9F, (female connector) on the front panel is connected to a PC with Windows terminal emulation software, the TRTC series can be remotely monitored, controlled and calibrated using RS232 ASCII commands.

### 2.3.1.1 Wiring Set-Up Procedure

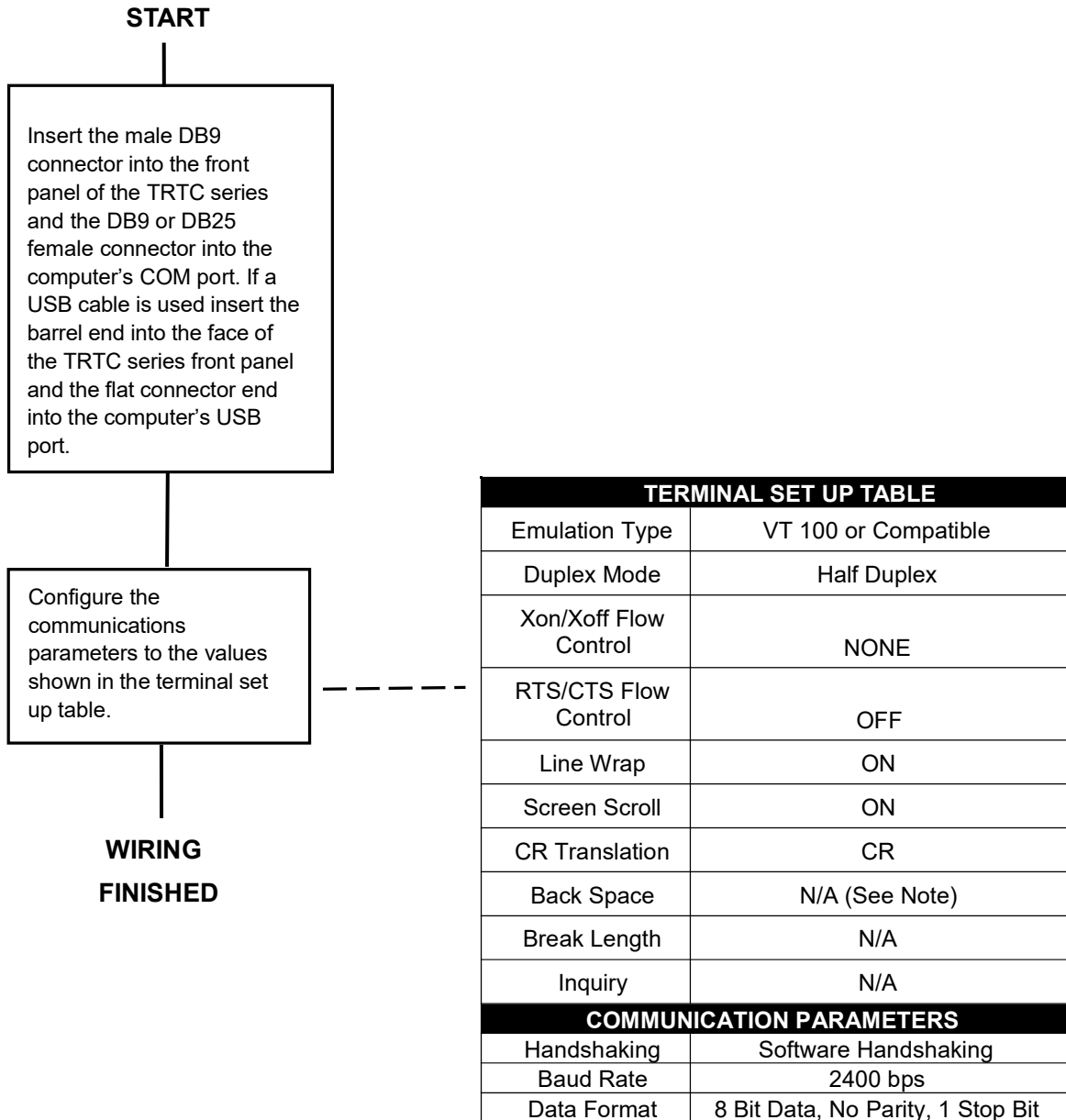

**TIP:** The program ignores the Backspace and Delete keys. If a command is wrong, press **Enter** and retype the command.

**TIP:** In Windows the path is: Start/Programs/Accessories/Communication/HyperTerminal.  
For a tutorial on how to connect the unit with Window's HyperTerminal, (see Section 2.3.2), "HyperTerminal Set Up."

## 2.3.2 HyperTerminal Set-Up

**Purpose:** Describes how to set up TRTC series RS232 / USB port using Windows Hyper Terminal program (see Figures 28 to 35)

The following Hyper Terminal setting is recommended for local or remote communication between TRTC series & PC. For this tutorial, Com 1 is used. Verify the designation of COM port, where RS232/USB cable to PC is connected such as COM1, COM2, etc.

**Step 1:** The path is: **Programs/Accessories/Communications/Hyper Terminal** as shown in Figure 28.

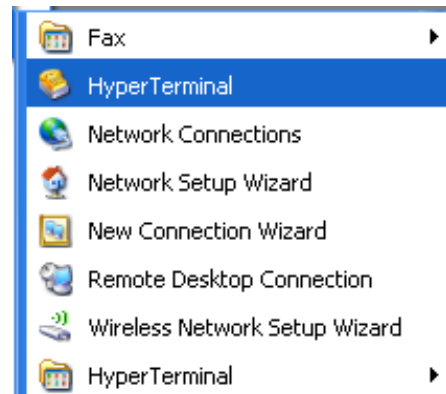

**Figure 28**

Hyper Terminal Selection Screen

**Step 2:** Click on the **Hyper Terminal** icon. **The Connection Description** screen (Figure 29) appears as shown. Enter a name and icon for your unit and click **OK**.



**Figure 29**

Connection Description Screen

**Step 3:**

The **Connect To** screen (Figure 30) appears.  
Select the COM port from the drop down menu as shown.

Click OK



**Figure 30**  
Connect to Screen

**Step 4:** The **COM Properties** screen appears (Figure 31).  
Select the port settings as shown.

**Step 5:** Click the **Advanced** button.

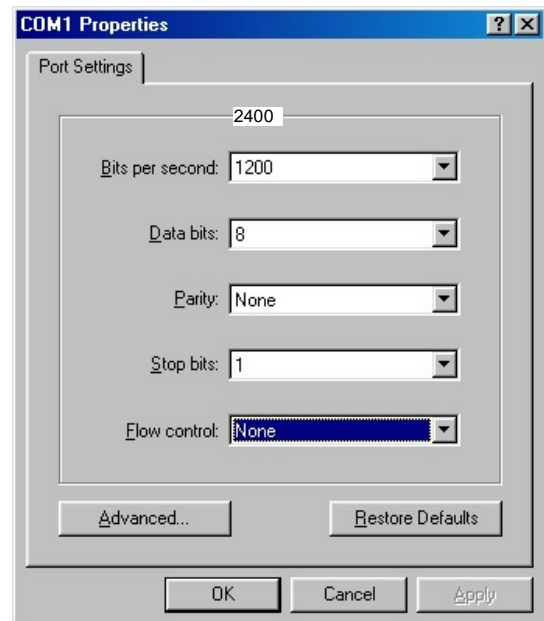

**Figure 31**  
COM Properties Screen

**Step 6:** In the **Advanced Port Settings** screen (Figure 32), Select the fields as shown.

**NOTE:** The Use FIFO buffers only applies to computers with 56Kbs modems or faster. For slower connections, leave box unchecked.

Click **OK**

The **COM Properties** Screen reappears (Figure 31). Click **OK**.

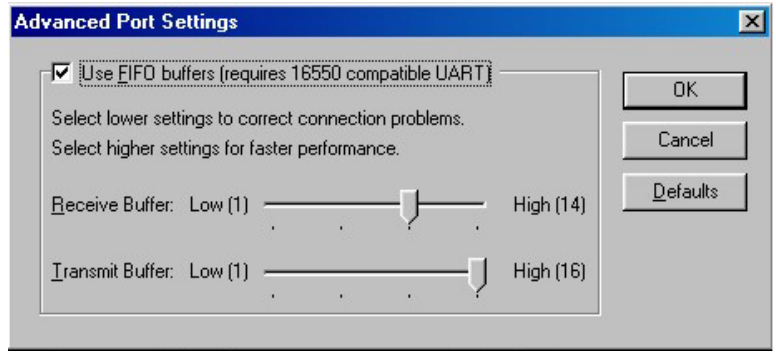

**Figure 32**  
Advanced Port Settings Screen

**Step 7:** A blank window with the entered file name appears (Figure 33).

In the **File** menu, go to **Properties** and **Click**.

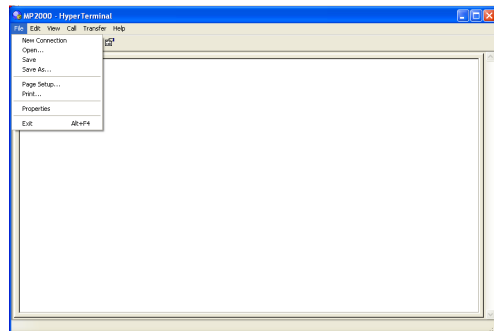
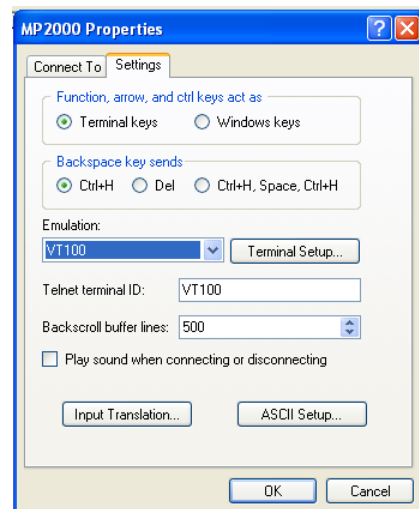

**Figure 33**  
TRTC Series Hyper Terminal Screen

**Step 8:** The **[Name of Unit] Properties** screen appears (Figure 34)

Click on the **Settings** Tab. Select the fields as shown.

**Step 9:** Click the **ASCII Setup** button.



**Figure 34**  
Properties Screen



**Step 10:** Select the fields in the **ASCII Setup** screen (Figure 35) as shown.

**Step 11:** Click **OK**. The **[Name of Unit]** properties window (Figure 34) reappears.

**Step 12:** Click **OK**

**HyperTerminal setup is completed.**

Press **Enter** to go to TRTC Series screen (Figure 33).  
Press **Enter** to access the unit via RS232 / USB communications.  
The Main Menu (Figure 36) appears.

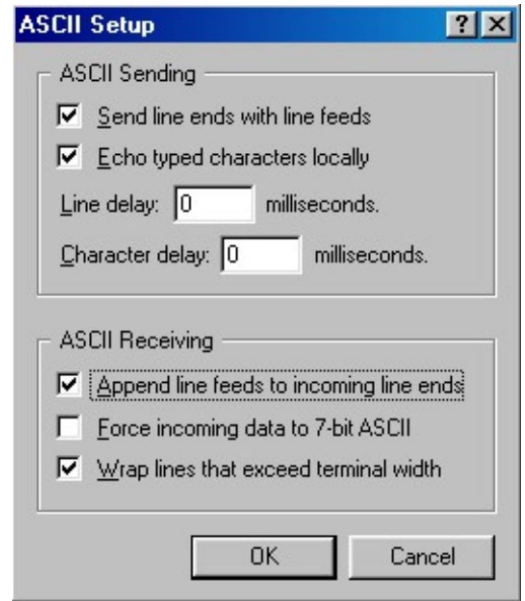

**Figure 35**  
ASCII Setup Screen

### 2.3.3 The Main Menu

**Purpose:** Describes the Main Menu (Figures 36 to 39).

The RS232 / USB menus are hierarchical. Press **ENTER** to access the top-level menu (Figure 36).

Figure 40 shows the Menu Tree.

The main menu displays the sub menu numbers, the line status, the unit's output status and any faults or alarms that may be present.

**TIP:** The factory set default password **1111** is required to access and set many functions, such as in menu 34 & menu 35.

**Procedure:**

To access a particular sub menu, type in the sub menu number and press Enter. To update the screen, press **Enter**.

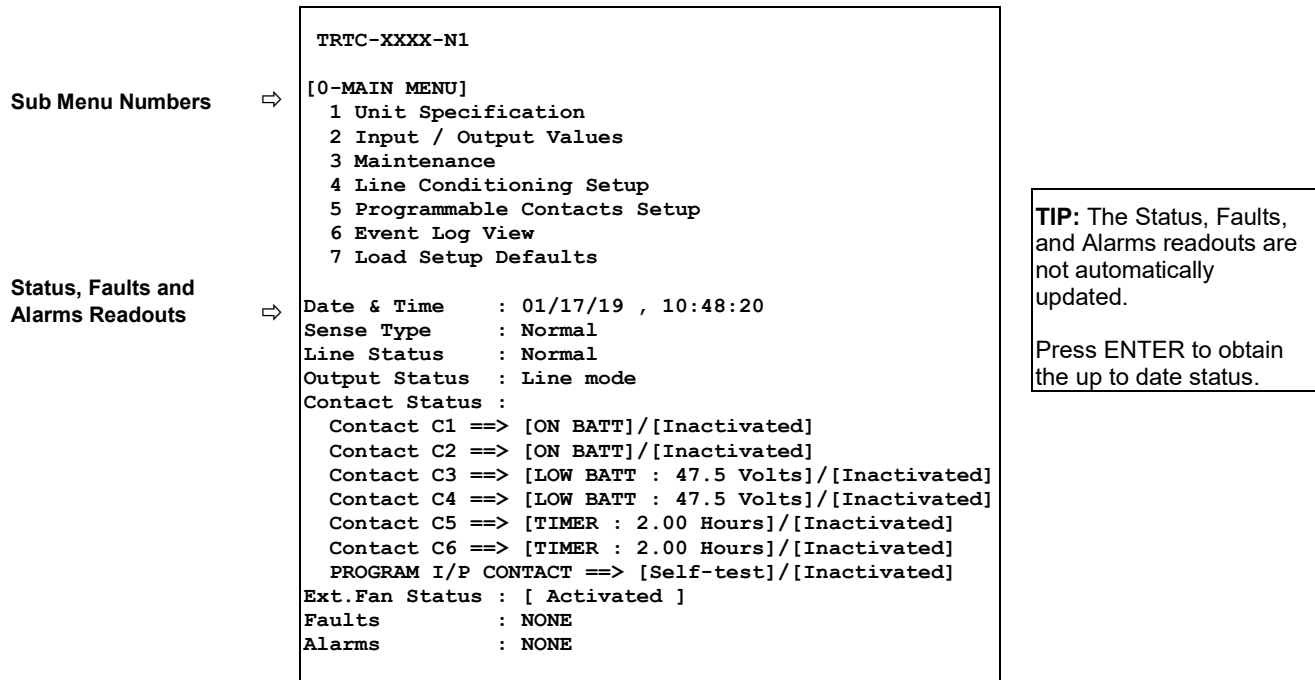

**Figure 36**  
Main Menu Screen

Tabulation of various items that appears under the Line Status, Output Status, Faults and Alarms are shown in figures: 37, 38 and 39.

Line Status: [Current Status]  
 Output Status: [Current Status]  
 Content Status: [Current Status]  
 Ext. Fan Status: [Current Status]  
 Faults: [If any, otherwise blank]  
 Alarms: [If any, otherwise blank]  
 >\_

LINE STATUS	
Normal	Input power is normal
Boost	Input power is out of tolerance. Boost mode is activated
Buck	Input power is out of tolerance. Buck mode is activated
Blackout	Input voltage is not available
Low	Input voltage is lower than programmed low limit
High	Input voltage is higher than programmed Hi limit
Freq low	Input frequency is too low (<45 Hz)
Freq high	Input frequency is too high (>55 Hz)

**Figure 37**  
 Line Status Displays

OUTPUT STATUS
Line Mode
Inverter Mode
Inverter mode, Low bat, warning
Inverter mode (testing battery)
Boost mode
Buck mode
Hot swap mode
Shutdown due to fault
Shutdown due to low battery
Shutdown due to no line

**Figure 38**  
 Output Status Displays

Line Status: [Current Status]  
 Output Status: [Current Status]  
 Content Status: [Current Status]  
 Ext. Fan Status: [Current Status]  
 Faults: [If any, otherwise blank]  
 Alarms: [If any, otherwise blank]  
 >\_

FAULT DISPLAYS	
Short-Circuit	Output Short Circuit
Vout_Hi	Output Voltage High
Vbat_Hi	Battery Voltage High
Vbat_Lo	Battery Voltage Low
Temp_Hi	Ambient Battery Temperature High or Internal Temperature High
Iout_Hi	Output Current High
EEPROM_Fit	Error Reading EEPROM
Wout_Hi	Output Power High (Overload)
Bad_Battery	Bad Battery
ALARM DISPLAYS	
Vout_Lo	Output Voltage Low
Overload	Output Overload
Temp_Lo	Ambient Battery Temperature Low
PII	Phase Lock Loop Cannot Lock with input
Line Freq	AC Line Frequency High or Low
Temp_Probe_Disconnect	Temperature probe uninstalled or disconnected
Batt_Not_Connect	The battery breaker is off or the batteries are discharged
Program Input Alarm	The program input contact alarm detected.

**Figure 39**

Fault and Alarm Displays

## 2.3.4 Menu Tree & RS232 / USB Sub Menus

**Purpose:** Describes the RS232 / USB Menu Tree that include: Unit Specifications, Input / Output Values, Maintenance and Line Slow Detection Setup Sub Menus (Figures 40 to 45)

### 2.3.4.1 RS232 / USB Menu Tree

The complete MENU Tree is shown on the next page with all default values.

Press ENTER to go back to the Main Menu

**TIP:** To access any item from the Main Menu. Type in the function number and press ENTER.

RS232 / USB Menu Tree

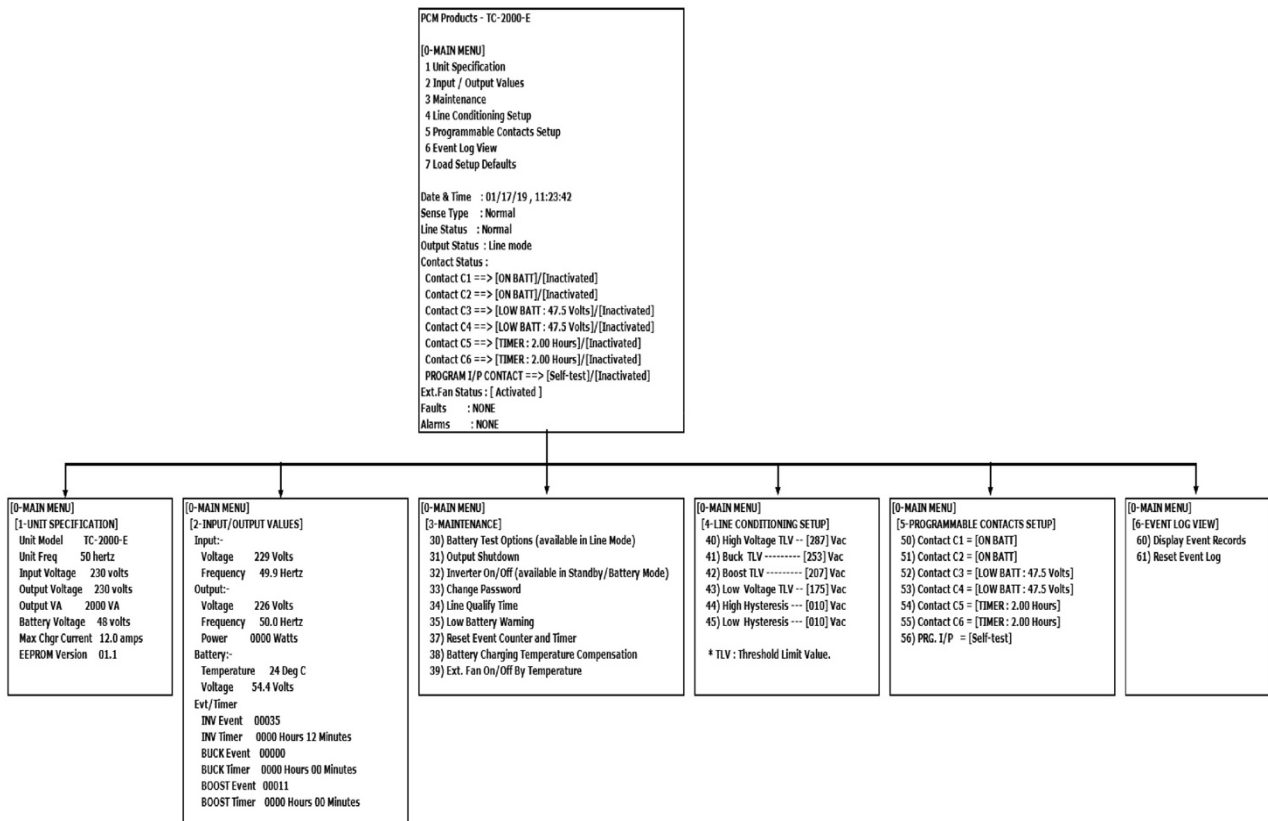

Figure 40

Com Port Menu Tree

### 2.3.4.2 Unit Specifications, Input / Output Values

Menu 1 below (Figure 41) lists the TRTC series specifications.

**Procedure:** At the main menu, type **1** and press Enter. The screen displays the Unit Specifications as shown below. To return to the main menu, press **Enter**.

[ 1 - Unit Specifications ]		
Unit Model	TRTC-XXXX-N1 / H2	The model name
Unit Freq	50 / 60 hertz	Nominal operating frequency
Input Voltage	120 or 230 Volts	Nominal Input voltage
Output Voltage	120 or 230 Volts	Nominal output voltage
Output VA	2000 VA	The output VA capacity
Battery Voltage	48 Volts	Nominal battery capacity
Max Charge Current	12 amps	MAX charge capacity
EEPROM Version	01.1	EEPROM version of the TRTC series

**Figure 41**  
Unit Specifications Menu

### 2.3.4.3 Input / Output Values

Menu 2 below (Figure 42) lists the actual measurements of various input / output parameters.

**Procedure:** At the main menu, type **2** and press Enter. The screen displays the Unit Specifications as shown below. To return to the main menu, press **Enter**.

[ 2 – Input / Output Value ]		
<b>INPUT</b>		
Voltage	120 or 230 Volts	The Input voltage
Freq	50.0 / 60.0 Hertz	The Input frequency
<b>OUTPUT</b>		
Voltage	120 or 230 Volts	The output voltage
Freq	50.0 / 60.0 Hertz	The output frequency
Power	0000 Watts	The output power in watts
<b>BATTERY</b>		
Temperature	24 Deg C	The ambient temperature of the battery case as read via attached temperature probe
Voltage	27.4 Volts	The battery DC voltage
<b>EVT/TIMER</b>		
INV Event	00035	The numbers of Input Power Failures
INV Timer	0000 Hours 12 Minutes	Total time that the battery was discharged since the last RESET
BUCK Event	00000	The numbers of BUCK function active
BUCK Timer	0000 Hours 00 Minutes	Total time that the BUCK function since the last RESET
BOOST Event	00000	The numbers of BOOST function active
BOOST Timer	0000 Hours 00 Minutes	Total time that the BOOST function since the last RESET

**Figure 42**  
Input / Output Values Menu

### 2.3.4.4 Maintenance

Menu 3 below (Figure 43) lists the various maintenance options.

#### Procedure

At the main menu, type 3 and press ENTER. The Maintenance Menu shown below is displayed. To return to the main menu, press ENTER.

[ 3 - Maintenance ]	
30 Battery Test Options	The start - stop for the Battery Test / Self-Test is initiated here. The test duration is user programmable in 1-minute intervals from 1 to 255 minutes. The factory default setting is 1 minute. <b>Tip:</b> The time duration can be changed only when the TRTC is in line mode.
31 Output Shutdown	This allows output to be switched OFF or Shutdown. The TRTC switches to STANDBY mode when this option is activated.
32 Inverter On/Off	During the BATTERY or STANDBY mode, this option allows the inverter to be switched OFF or turned ON after the user programmable delay time. The delay can be user programmable in 0.5 seconds steps from 0 to a maximum setting of 255 steps (128 seconds). The delay is only available in Standby or Battery modes. When the unit returns to Line Mode, the delay resets back to a default of 0 seconds. Thus, during a battery discharge or ON BATTERY mode, operator can stop the inverter immediately after user.
33 Change Password *	This option allows for the change of password. The factory set default password is 1111. <b>Tip:</b> the password can only be changed in Line mode.
34 Line Qualify Time	When the input power returns and it is qualified, i.e. it is within acceptable range, the transfer from Battery mode to Line mode is delayed by user programmed 3 / 10 / 30 seconds herein that allows the returned utility power to settle down. The factory set default value is 30 seconds.
35 Battery Voltage Low Warning	The level for LOW BATTERY ALARM is set here. The Voltage level is user programmable in 0.5VDC increments from 24.2VDC to 27.4VDC. The factory default setting is 27.4VDC or 40%. The relationship between Remaining % capacity of battery and its DC Voltage depends on the characteristics of the batteries used.
37 Resets The Event/Timer Counters	Resets INV, BUBK, BOOST Event to 0 Resets INV, BUBK, BOOST Timer to 0
38 Battery Charging Temperature Compensation	Temperature compensated smart charger is utilized in TC UPS. The rate of charging is adjusted here based on the battery case temperature. The factory default value is set at -3mv/deg°C /Cell. It can be configured to -2.5/ -3 / -4 / -5 mv/deg°C /Cell.
39 Ext. Fan On/Off By Temperature	Set the temperature in °C, above which the 24/48VDC power will be provided for external cooling fan. The temperature can be set in 1°C increment from 20 to 55°C. The factory default temperature is set at +25°C.

**Figure 43**  
Maintenance Menu

## **\*Password Changing Procedure**

1. Go to Menu 33.
2. Type the current password (the factory set password is 1111) and press **Enter**.
3. The words "Enter New Password" appears on the screen. Type the new password (any combination of 4 digits) and press **Enter**.

**NOTE:** The password can ONLY be four numeric digits – NO ALPHA CHARACTERS.

4. The words "Re-enter New Password" appear on the screen. Retype the new password and press **Enter**. If the wrong password is retyped, the screen displays "Error in entering data... please try again." Type the correct password and press **Enter**.

If the retyped password is correct, the screen returns to the main menu.

*For a tutorial on how to use the menu screens, (see Section 2.3.5).*



### 2.3.4.5 Line Slow Detection Parameters

This option allows user to change various detection and warning levels for input AC voltages, qualified and unqualified values, Transfer & Retransfer set points for going in & out of Battery mode / Boost / Buck modes. The factory set default values concur with those specified by major DOTs (Department of Transportations). See Figure 45 for a description of each parameter.

Electrical equipment is designed to operate at maximum efficiency at a specific standard supply voltage. Buck and boost is an ideal solution when the line voltage is consistently higher or lower than nominal. The transformer can buck (lower) or boost (raise) the supply voltage without having to go onto battery or involve any other active TRTC UPS board level components. The TRTC series input transformer has a second tap off the primary winding. When activated, the transformer will automatically switch to the secondary tap to buck or boost the voltage output 10%, thereby keeping the output within an acceptable range.



**CAUTION:** Improperly set parameter values can cause **permanent damage** to the unit. Changes should only be made by Manufacturer trained personnel.

**Contact Manufacturer before making any adjustment.**



**Note:** Parameter values are interdependent, changing one value can affect range and permissible value in another field. This feature is to protect the user from entering conflicting values.

#### Parameter Change Procedure

1. Go to the Menu 4.
2. "Enter Password" appears (the factory set password is 1111), Type the password and press **Enter**.

If the wrong password is typed, the screen displays "Error in entering data... please try again." Type the correct password.

3. The Parameter Change Screen appears (Figure 44). Type the new value that is within the range of acceptable parameter limits and press **Enter**.

The screen returns to the Line Slow Detection Screen. For example:

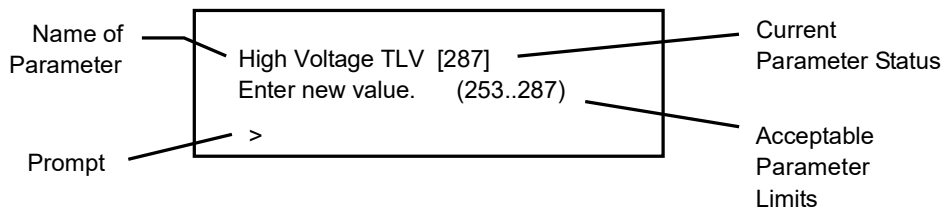

**Figure 44**

Parameter Change Screen

(Slow Detect High Limit Screen Shown)

For a tutorial on how to use the menu screen, see Section 2.3.5

**TRTC 120V series Parameter Descriptions**

(All levels are user programmable; some values are interdependent)

		AVR Feature Disable		AVR Feature Enable	
		Default Setting	RANGE	Default Setting	RANGE
<p><b>40 Slow Detect High Voltage TLV</b> When input voltage exceeds this level, TRTC 120V series transfers to Battery Mode from either Buck Mode (when enabled) or Line mode.</p>	On Battery Mode Line / Buck to Battery	130VAC	120~150VAC	150VAC	120~150VAC
<p><b>High Voltage Hysteresis</b> When input voltage returns below this level, TRTC 120V series transfers back to Line Mode from Battery Mode.</p>	Battery to Line -----	*125VAC ( High Lmt - High Gap )		*145VAC ( High Lmt - High Gap )	
<p><b>41 Slow Detect Buck TLV</b> When input voltage exceeds this level, TRTC 120V series transfers to Buck Mode (when enabled) reducing the output.</p>	Line to Buck -----	[DISABLE]		130VAC	[DISABLE]
<p><b>Buck Low Voltage Hysteresis</b> When input voltage returns below this level, TRTC 120V series releases the Buck Mode (when enabled) and transfers back to the Line Mode.</p>	Buck to Line -----	[DISABLE]		*125VAC ( Buck High - High Gap )	
	Normal -----				
<p><b>Boost High Voltage Hysteresis</b> When input voltage returns above this level, TRTC 120V series releases the Boost Mode (when enabled) and transfers back to the Line Mode.</p>	Boost to Line -----	[DISABLE]		*107VAC ( Boost Low + Low Gap )	
<p><b>42 Slow Detect Boost TLV</b> When input voltage reduces below this level, TRTC 120V series transfers to Boost Mode (when enabled) increasing the output.</p>	Line to Boost -----	[DISABLE]		102VAC	[DISABLE]
<p><b>Low Voltage Hysteresis</b> When input voltage returns above this level, TRTC 120V series transfers back to the Line Mode from Battery Mode.</p>	Battery to Line -----	*105VAC ( Low Lmt + Low Gap )		*95VAC ( Low Lmt + Low Gap )	
<p><b>43 Slow Detect Low Voltage TLV</b> When input voltage reduces below this level, TRTC 120V series transfers to Battery Mode from either Boost Mode (when enabled) or Line Mode.</p>	Line / Boost to Battery On Battery Mode	100VAC	90~120VAC	90VAC	90~120VAC
<p><b>44 High Hysteresis</b></p>		5VAC	3~7VAC	5VAC	3~7VAC
<p><b>45 Low Hysteresis</b></p>		5VAC	3~7VAC	5VAC	3~7VAC

**Figure 45**  
Parameter Values

**TRTC 220/230/240V series Parameter Descriptions**  
 (All levels are user programmable; some values are interdependent)

	220V		230V		240V	
	Default Setting	RANGE	Default Setting	RANGE	Default Setting	RANGE
<b>40 Slow Detect High Voltage TLV</b> When input voltage exceeds this level, TRTC 2X0V series transfers to Battery Mode from either Buck Mode (when enabled) or Line mode.	On Battery Mode Line / Buck to Battery					
<b>High Voltage Hysteresis</b> When input voltage returns below this level, TRTC 2X0V series transfers back to Line Mode from Battery Mode.						
<b>41 Slow Detect Buck TLV</b> When input voltage exceeds this level, TRTC 2X0V series transfers to Buck Mode (when enabled) reducing the output.	Battery to Line -----					
<b>Buck Low Voltage Hysteresis</b> When input voltage returns below this level, TRTC 2X0V series releases the Buck Mode (when enabled) and transfers back to the Line Mode.						
	Line to Buck -----					
<b>Boost High Voltage Hysteresis</b> When input voltage returns above this level, TRTC 2X0V series releases the Boost Mode (when enabled) and transfers back to the Line Mode.						
<b>42 Slow Detect Boost TLV</b> When input voltage reduces below this level, TRTC 2X0V series transfers to Boost Mode (when enabled) increasing the output.	Buck to Line -----					
<b>Low Voltage Hysteresis</b> When input voltage returns above this level, TRTC 2X0V series transfers back to the Line Mode from Battery Mode.						
<b>43 Slow Detect Low Voltage TLV</b> When input voltage reduces below this level, TRTC 2X0V series transfers to Battery Mode from either Boost Mode (when enabled) or Line Mode.	Normal -----					
<b>44 High Hysteresis</b>						
<b>45 Low Hysteresis</b>	Boost to Line -----					
	Line to Boost -----					
	Battery to Line -----					
	Line / Boost to Battery On Battery Mode					
	( High Lmt - High Hyst )					
	( Low Lmt + Low Hyst )					
	10VAC					
	8~12VAC					

**Figure 46**  
Parameter Values

## 2.3.5 Menu Tutorial

**Purpose:** shows how to use the menus (Figures 47 to 50)

This tutorial shows how to change the Battery Test Options. The other menus function in the same manner.

1. At the main menu (Figure 36), type 3 and press **Enter**.

The Maintenance Menu 3 appears as below (Figure 47).

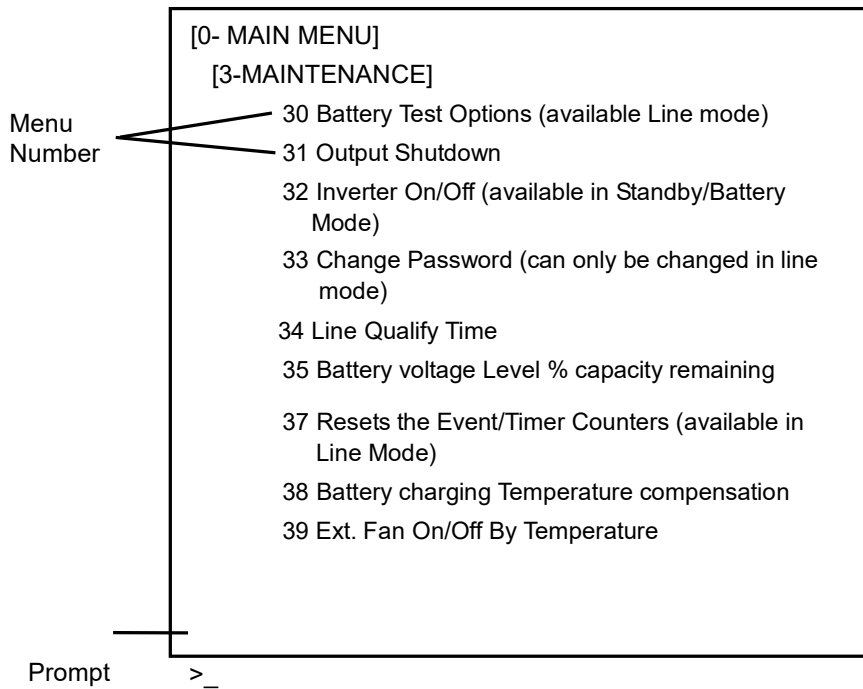

**Figure 47**  
Maintenance Menu Screen

To the left of each maintenance option is a Menu number. Typing **30** and pressing **Enter** calls up the Battery Test Options screen (Figure 48).

2. Numbers or words inside square brackets show the present status value of that menu item.

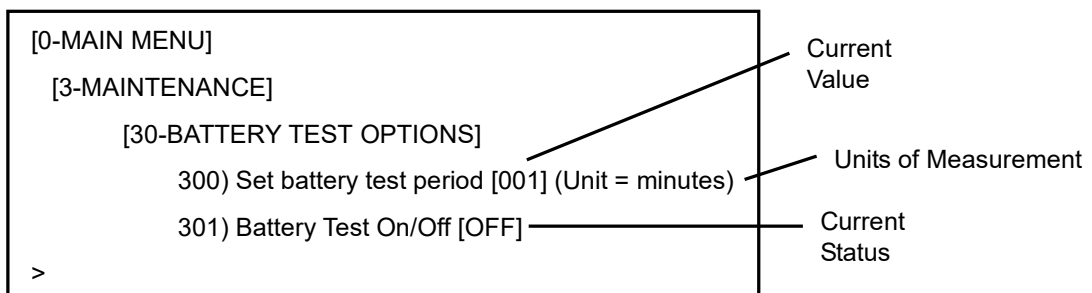

To calculate the Test Period: Test Period = Current Value X Units

*Example: Test Period = 001 x 1 Minute = 1 Minute*

**Figure 48**  
Battery Test Options Screen

3. To change the battery test period, type **300** and press **Enter**.

The words "Enter Password" appear on the screen. Type the password (the factory set password is 1111) and press **Enter**. If the wrong password is typed, the screen displays "Error in entering data... please try again." Type the correct password and press **Enter**.

The Set Battery Test Period screen appears as below (Figure 49).

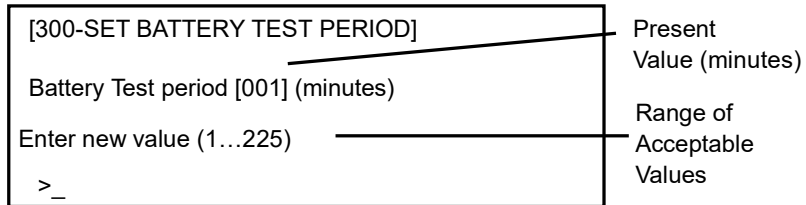

**Figure 49**  
Set Battery Test Period Screen

Type in the new value within the acceptable range and press **Enter** to change the test period and go back to the maintenance menu screen.

4. To change the Battery Test On/Off status, type **301** and press **Enter**.

The words "Enter Password" appear on the screen. Type the password and press **Enter**.

The battery Test Screen appears (Figure 50).

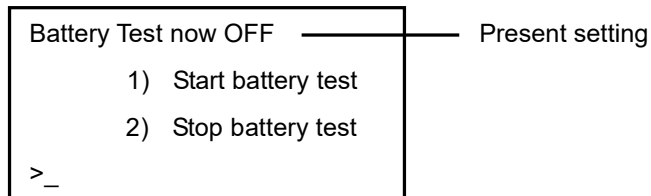

**Figure 50**  
Battery Test Screen

Type **1** to start the battery test, or **2** to stop the battery test, and press **Enter**. This will change the battery test status and return you to the maintenance menu screen.

## 2.4.1 Battery Back-Up Time Test

**Purpose:** Describes how to measure the back up capacity of batteries.

This test provides the measurement of back-up time during power outage by actually discharging the batteries. The back-up time is load as well as battery dependent, thus more back-up time is available with a lower load (in Amps or Watts) and less time with more load.

**Tip:** It is recommended to perform this test every 6 months.

**Tip:** Make sure the batteries are fully charged before starting this test.

### PROCEDURE

#### **EXAMPLE:**

Start time is **1PM**.  
ON BAT contact if selected, is activated.

Low Battery Alarm LED appears at **4PM**.  
LOW BAT contact at selected value will be activated.

Low Battery capacity battery back-up time will be the time difference between 4PM and 1PM or **3 hours**.

Shutdown time is **5PM**.  
Battery reserve time will be the time difference between 4PM and 5PM or **1 hour**.

The **Total Battery Back-up** time is the sum of Low Battery capacity back-up time and Battery Reserve time or the time difference between 5PM and 1PM or 4 hours.

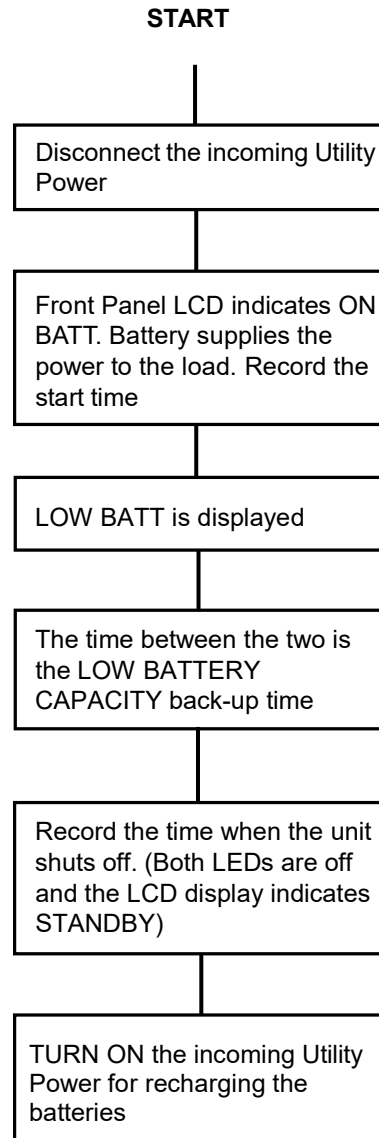

## 2.4.2 Battery Maintenance

The batteries are maintenance-free. Battery life can be affected by many factors such as: operating temperature, number of discharges during the battery's life, and periodic Preventative Maintenance (see 2.4.1). This system complies with the battery manufacturer's specifications for optimum performance and the longest possible battery life.

## 2.4.3 Emergency Shutdown Procedure

TURN-OFF BOTH THE AC & BATTERY BREAKER IN AN EMERGENCY. The TRTC UPS contains more than one live circuit. In an emergency, AC line power may be disconnected at the system's input, but output AC power may still be present from batteries.

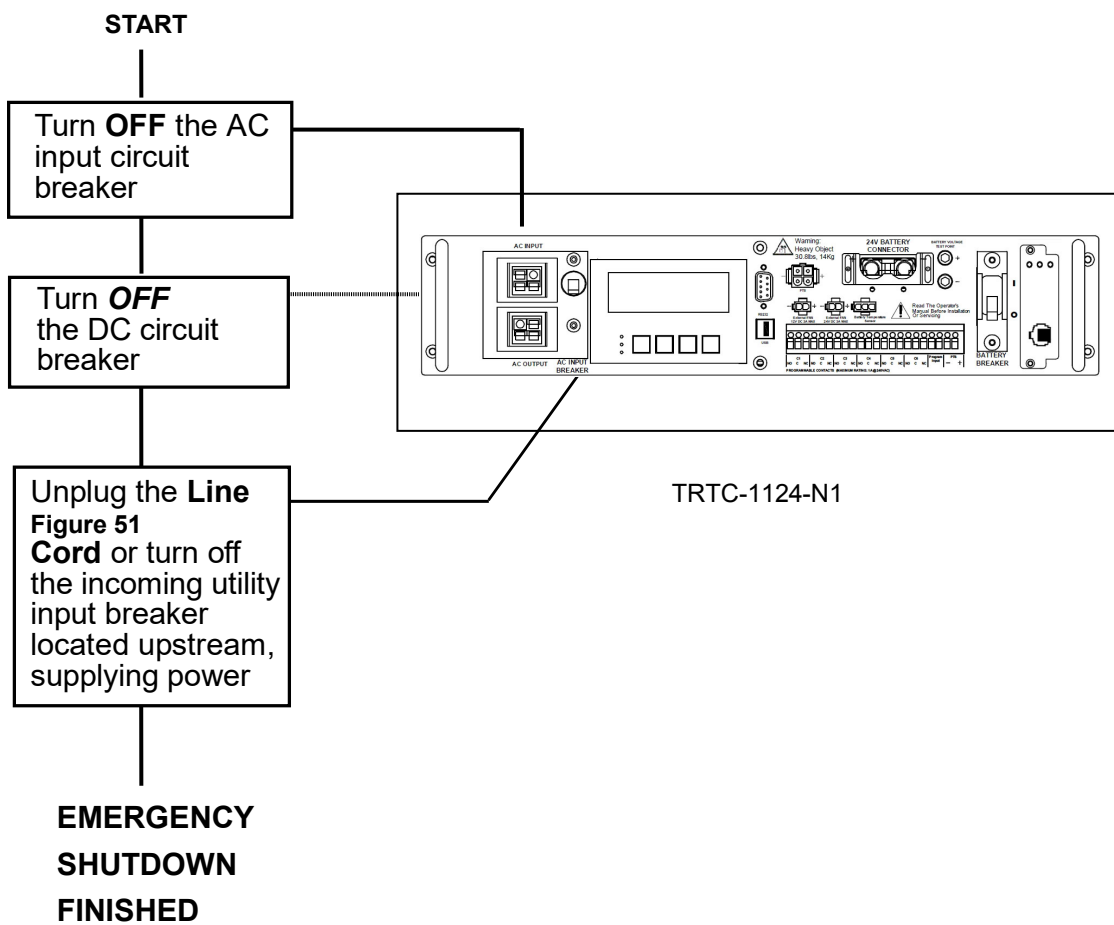

## 2.4.4 Troubleshooting

**Purpose:** Describes the most common problems with the TRTC Series.

There are NO Maintenance items inside the TRTC Series and it should be opened or serviced only by factory authorized service personnel, failure to do so will void the WARRANTY. If it fails to perform a specific function, Figure 50 below lists typical symptoms, causes and solutions. If you cannot resolve a problem, contact Manufacturer customer service department.

SYMPTOM	CAUSE	REMEDY
<b>No Output</b>	AC input circuit breaker is OFF	Turn input circuit breaker on
	No incoming utility line power	Apply incoming utility power by closing upstream breaker
	Red LED is lit solid on front indicating FAULT	Read the FAULT under Status Menu of LCD display. See 2.2.13. Clear the fault. Shut off both the breakers on the front panel. Restart. Contact the factory, if fault persists
<b>Output LED OFF</b>	Incoming utility power or battery power not available	Apply qualified input power and verify battery breaker is closed
	Faulty unit	Contact factory
<b>Unit does not transfer to Battery mode during a power failure</b>  <b>OR</b>  <b>Backup time is less than rated</b>	Battery Not connected	Connect batteries
	Battery circuit breaker OFF	Close battery breaker
	Battery is not fully charged	Fully recharge the battery then test backup time (see 2.4.1)
	Dead battery	Replace with a good battery
	Battery failure	Clean and tighten battery connections Check batteries and replace if needed
	Faulty unit	Contact vendor
<b>Fault LED is lit</b>  <b>Alarm LED is lit</b>	Red LED steady ON indicates FAULT	Correct the Fault (see 2.2.13)
	Yellow LED steady ON indicates ALARM	Correct the Alarm (see 2.2.12). Contact the factory if Alarm persists



<b>Batteries will NOT charge</b>	Battery circuit OPEN	Check that battery connections have proper torque Check battery cable harness for connection error, loose / open connections Check battery voltage is correct Check if battery breaker is closed Replace the bad battery, if any
	Wrong or bad temperature probe connected at front panel	Use Factory supplied temperature probe reading approximately 10,000 OHMS @ 25°C (77°F)
<b>LCD screen NOT readable</b>	Adjust the contrast for LCD screen	Press and hold ESC button. Press ENTER button Adjust the contrast using UP or DOWN arrow buttons Press ENTER when completed
	Faulty unit	Contact Factory
<b>Password Access NOT available</b>	Entered Password is LOST or forgotten	Call factory for resetting of the new password

**Figure 50**  
Troubleshooting Table

<b>CONTRAST ADJUSTMENT FOR LCD DISPLAY</b>
<ol style="list-style-type: none"> <li>1. While pushing the ESC button on the front panel</li> <li>2. Press the ENTER button and adjust the contrast up or down</li> <li>3. Press ENTER when adjustment is complete</li> </ol>

## 2.4.5 Specifications

Functions	
Brownout Protection	This unit boosts the output voltage (or transfers to Battery) during Brownout or Low input line conditions and returns to Normal when input power stabilizes and returns to Normalcy. These values for Transfer / Retransfer, To / From Battery / Boost mode are user programmable
Generator Compatibility	Generator mode allows for more variations in input voltage and frequency for use with an AC generator
Battery Charger 10A	PFC switch-mode charger is temperature-compensated (-2.5 to -5 mV/C/Cell) with automatic shut off above 50 deg C
Inverter Mode	Capable of running continuously in inverter mode
Inverter Mode Current Limit	Continuous electronic current limit is provided
Measurements available for remote monitoring	<ul style="list-style-type: none"> <li>- Input and output voltages</li> <li>- Input line frequency</li> <li>- Battery voltage and current</li> <li>- Battery and heat sink temp</li> </ul>
Mechanical Specifications	
Dimensions (H x W x D)	TRTC-0654-N1/N2/H1/H2, TRTC-1124-N1/N2/H1/H2: 88.6 mm x 432 mm x 254 mm 2U 3.5" x 17.0" x 10" TRTC-2005-N1/N2/H1/H2: 3U 133 mm x 432 mm x 254 mm 5.3" x 17.0" x 10"
Weight	TRTC-0654-N1/N2, TRTC-1124-N1/N2: 13 kg / 29 lbs TRTC-2005-N1/N2: 21 kg / 46 lbs
Input Connection	3 Position Terminal Block OR Anderson PP45 Quick connector OR IEC socket
Output Connection	3 Position Terminal Block OR Anderson PP45 Quick connector OR IEC socket
Mounting	19" (483 mm) or 23" (584 mm) rack/shelf mount
Cooling (Ext. Fan) Microprocessor controlled	DC Fan TRTC-0654-N1/N2/H1/H2, TRTC-1124-N1/N2/H1/H2, 24VDC, TRTC-2005-N1/N2: 48VDC
Audible Noise Level	<40 dBA
Operating Temperature	-37° C to + 74° C / -35° F to +165° F
Storage Temperature	-50° C to + 75° C / -58° F to +167° F
Humidity	Less than or equal to 95%, Non-Condensing
Altitude	10,000 ft / 3048 meters (See Note 1)

Electrical Specifications	
Output Apparent Power	TRTC-0654-N1/N2/H1/H2: 650VA TRTC-1124-N1/N2/H1/H2: 1100VA TRTC-2005-N1/H2: 2000VA (Inverter Mode) 2000VA (Line Mode)
Output Active Power Inverter Mode and Line Mode	TRTC-0654-N1/N2/H1/H2:650W TRTC-1124-N1/N2/H1/H2:1100W TRTC-2005-N1/N2/H2/H2: 2000W
Power Factor	1.0
Input Frequency +/- 3Hz Output Frequency +/- 0.3Hz	120V: 60Hz 220/230/240V: 50/60Hz
Input Voltage Range	120V: 90 to 150 VAC User programmable 220V: 168 to 275 VAC User programmable 230V: 175 to 287 VAC User programmable 240V:183 to 300 VAC User programmable
Output Voltage Inverter Mode	120/220/230/240 VAC (Tolerances are User programmable) 120/220/230/240 VAC+/-5%
Maximum Input Current	120V: TRTC-0654-N1/H1, TRTC-1124-N1/H1: 20A TRTC-2005-N1/H1: 30A 220/230/240V: All Models: 20A
Transformer	Linear (Non-Isolated)
Transfer Time, msec	< 40 msec < 65 msec (UPS + PTS)
Inrush Current	Load Dependent
Output Waveform THD	< 3 % (Resistive Load)
Load Crest Ratio	3:1
Efficiency, Line Mode	> 95% (Resistive Load)
Efficiency, Inverter Mode	> 80% (Resistive Load)
Nominal Battery String Voltage	TRTC-0654-N1/N2/H1/H2: 24VDC TRTC-1124-N1/N2/H1/H2: 24VDC TRTC-2005-N1/N2/H1/H2: 48VDC
Step Load Response	1 Cycle Full recovery.
Over current Protection	Single pole circuit breaker for input TRTC-0654-N1/H1 TRTC-1124-N1/H1: 20A (120V) TRTC-2005-N1: 30A 220/230/240 VAC: All Models: 20A DC Bus: TRTC-0654-N1/H2 & TRTC-1124-N1/H2: 60Amp Circuit Breaker. TRTC-2005-N1/H2 90Amp Circuit Breaker
DC Power	Drawn from batteries

## 22 Position Terminal Block

Functions	<p>A. Provides 6 sets of programmable contacts at pin 1 thru pin 18 for intersection flash control, Remote Alarms, Pagers or other user interface.</p> <ol style="list-style-type: none"> <li>1. "Low Batt": batteries have reached approximately 40% capacity remaining</li> <li>2. "On Batt": unit is in inverter mode</li> <li>3. "Timer": unit has been in inverter mode for 2 hours (programmable)</li> <li>4. "Alarm": any of the following conditions occur:             <ol style="list-style-type: none"> <li>a. Any alarm</li> <li>b. Line freq. un-match</li> <li>c. Output under voltage</li> <li>d. Temp. Probe disconnect</li> <li>e. Over load</li> <li>f. Batt. Not Connect</li> <li>g. Batt Hi Temp. &gt; +60 Deg C</li> <li>h. Batt Hi Temp. &lt; -15 Deg C</li> </ol> </li> <li>5. "Fault": any of the following conditions occur:             <ol style="list-style-type: none"> <li>a. Any fault</li> <li>b. Short circuit</li> <li>c. Battery under voltage</li> <li>d. Battery over voltage</li> <li>e. Battery over temperature</li> <li>g. Over load</li> </ol> </li> </ol> <p>B. Provides 24VDC (TRTC-0654-N1/N2/H1/H2, TRTC-1124-N1/N2/H1/H2,</p> <p>C. 48VDC (TRTC-2005-N1/N2/H1/H2) signal to PTS on pins 21 &amp; 22</p> <p>D. Provides programmable input contact on pins 19 &amp; 20.</p> <ol style="list-style-type: none"> <li>1. Self-test</li> <li>2. EXT. Alarm</li> <li>3. EXT. BATT Alarm</li> <li>4. EXT. FAN Alarm</li> <li>5. DOOR INTERLOCK</li> </ol>
Contact Type	Form C. Dry contacts rated 1 Amp at 240V
Wiring	Uses 14-26 AWG

## Communication Specifications

RS-232/USB/Ethernet ports	Monitors, controls and calibrates with terminal emulation software for service personnel to obtain unit diagnostics
RS-232	DB-9, Female, Opto-Isolated, straight-thru cable
USB	B-Type receptacle
Ethernet (optional)	10/100 Mbps Ethernet, auto-detected
Display Panel	4-line LCD

## Environmental

AC Input / Output Voltage	120V
Current	30 Amp
Switches <ul style="list-style-type: none"> <li>• Current</li> <li>• Voltage</li> <li>• Rated Conditional Short</li> </ul> <p style="margin-left: 40px;">Circuit Current</p>	<p>32A Max</p> <p>600V Max</p> <p>10kA</p>

Mechanical	
Dimensions (W x D x H) inches / mm	W 19 / 483 D 5.1 / 129 H 3.5 / 89 – 2U
Weight (lbs. / kg)	9.5 / 4.3
Mounting	Shelf or 19" Rack Mount
Input Connection	Hardwire Terminal Block
Output Connection to Loads	Hardwire Terminal Block
Cooling	Convection (approx. 7 W contractor coil dissipation)
Environmental	
Operating Temp °C / °F	-37°C (-35°F) to +74°C (165°F)
Storage Temp °C / °F	-50°C (-58°F) to + 75°C (167°F)
Humidity	<95% non-condensing
Altitude, ft. (m)	10,000 (3000)

**Note:** De-rate operating temperature above 4900 ft (1500m) by 2°C per 1000 ft (300m).

Due to ongoing product improvements, specifications are subject to change without notice.

## 2.4.6 TRTC Series Return Instructions

**Purpose:** Describes how to return the TRTC series for repairs.

Manufacturer does not assume responsibility for damage caused by improper packaging of returned units. The TRTC weighs approximately 35 lbs. and should only be shipped in a box or carton of sufficient thickness to withstand handling.

Before returning a UPS or any system component for repair or replacement, including batteries, a Return Material Authorization (RMA) number must be obtained from Customer service at the following Telephone / Address. Clearly write the RMA number on the original shipping container. If you do not have the original container, pack the unit with at least three inches of shock absorbing material, but do not use popcorn type material. Returns should be prepaid and insured (COD and freight collect cannot be accepted).

Contact Customer Service for ordering any parts or service.

For service, parts or technical information contact:

Marathon Power is available for customer service between 7:00am and 6:00pm PST, Monday-Friday and can be contacted as follows:

Phone: 310-689-2328

Fax: 310-689-2329

Email: support@marathon-power.com

Website: www.marathon-power.com

Address: 2538 E. 54th St., Huntington Park, CA 90255

## 2.4.7 Warranty

### 1. Limited Three-Year Warranty and Exclusions

Marathon Power warrants that this product at the time of its sale by Marathon Power, is free of defects in materials and workmanship for three (3) years from the original purchase date. The batteries used with our traffic units vary, and the battery warranty will follow the battery manufacturer's warranty. This warranty excludes labor for removal or re-installation of this product. This warranty is void if this product is installed improperly or in an improper environment, overloaded, misused, opened, abused, or altered in any manner, or is not used under normal operating conditions or not in accordance with all labels or instructions. There are no other or implied warranties of any kind, including merchantability and fitness for a particular purpose, but if any implied warranty is required by the applicable jurisdiction, the duration of any such implied warranty, including merchantability and fitness for a particular purpose, is limited to three years. Marathon Power is not liable for incidental, indirect, special or consequential damages, including damage to, or loss of use of, any equipment, lost sales or profits or delay or failure to perform this warranty obligation.

### 2. Limitations & Claims

This warranty does not cover any Marathon Power UPS or any properly connected electronic equipment which has been improperly installed, overloaded, abused or altered in any manner, or is not used under normal operating conditions, or in accordance with any labels or instructions, and does not cover any damage to properly connected electronic equipment resulting from a cause other than a "surge". Damage caused by failure to provide a suitable installation environment for the product (including, but not limited to, lack of a good ground) will not be covered by this warranty. This warranty does not apply to damage caused by direct lightning strikes, or damage caused by electrical disturbances that exceed published product specifications. These products are intended to limit the maximum amplitude of transient voltage surges on power lines to specified values. They are not intended to function as surge arrestors. The UPS is intended to be installed on the load side of the service entrance and has been tested to verify that transient voltage surges are limited when subject to non-repetitive transient voltage surge events. This warranty excludes any incidental, indirect, special or consequential damages, including without limitation, labor for removal or reinstallation of the Marathon Power UPS or any connected electronic equipment, data loss or alteration loss of equipment use, lost sales or profits and any such damages for delay or failure to perform this warranty obligation. This warranty is in lieu of and excludes all implied warranties of merchantability or fitness for use. In addition, the warranty does not cover restoration of lost data and reinstallation of software. Some states may not allow the exclusion or limitation of incidental or consequential damages or other remedies, so the above exclusions or limitations may not apply to you. To file a warranty claim, contact us at Marathon Power, Inc., Attn: Returns, 2538 E. 54th Street, Huntington Park, California 90255, or call (310) 689-2328 or email us at support@marathon-power.com within 30 days of the occurrence. Marathon Power is not responsible for shipping costs. Be prepared to provide detailed information about the event, any damage, the model and serial number, purchase date and location. You will then be provided with a Return Material Authorization (RMA) Number, and be instructed to provide an explanation of the event and information about the state of your unit. If Marathon Power determines that the damage was due to a "surge", we may request that all connected equipment be submitted for evaluation. The warranty coverage is above and beyond, only to the extent needed, of that provided by any other source, including but not limited to any connected equipment coverage, any manufacturer's warranty or insurance policy.







Marathon Power, Inc. 2023

2538 E. 54th Street  
Huntington Park, CA 90255  
Office: 310-689-2328  
Fax: 310-689-2329

[support@marathon-power.com](mailto:support@marathon-power.com)  
[www.marathon-power.com](http://www.marathon-power.com)