



Vault HP Series

**True On Line,
Double Conversion
Uninterruptible Power Supply**

USER MANUAL FOR MODELS:

6kVA - 10kVA

Table of Contents

Section	Page
1.Introduction	8
2.System Description	8
2.1 General Description.....	8
2.2 System Configuration.....	10
3.Safety Information	10
4.Storage	11
5.Installation	11
5.1 Environment.....	11
5.2 AC Power and Load Connections.....	12
5.3 RearPanelViews.....	17
5.3.a Tower Models - 4k / 5kVA Rear Panel Views.....	17
5.3.b Tower Models - 6kVA Rear Panel Views	18
5.3.c Tower Models 8k / 10kVA Rear Panel Views.....	18
5.4 Connection to Mains Run and Loads (6000-10000).....	19
5.5 FactoryDefault Settings.....	20
6.Communication Interface and Alarm Connections	21
6.1 EBP Port.....	21
6.2 Network Transient Protector (Optional).....	22
6.3 Load Segments (Where applicable).....	22
7.Operational Instructions	23
7.1 Starting Up and Shutting Down the UPS.....	23
7.2 Push-button Operations.....	23
7.3 Control Panel Indicators.....	24
7.4 LCD Panel Display Modes.....	25
7.5 Manual UPS or Battery Test.....	26
7.6 Sense Mode – Normal and Generator Waveforms.....	27
7.7 AudibleAlarms.....	27
7.8 Troubleshooting.....	28
8.Maintenance	29
8.1 Battery Replacement.....	29
9.Specifications	32
10.Warranties	35

CISPR 22

NOTICE: Pursuant to CISPR 22 rules, this product has been tested and thereby complies with the conditions of a class C2 (6KVA and 10KVA) and Class A digital device, which have been established for offering sufficient protection against dangerous interference for installation in a residential area. Installation and use of the equipment should comply with the instructions provided in order to avoid such interference due to the amount of radio frequency energy that is radiated and generated by the equipment. In spite of this, we cannot assure that a certain amount of interference may not occur in some installations. If, by turning on and off, it can be deduced that your radio or television reception is found to be influenced by harmful interference from the equipment, it is recommended to use one of the following preventive measures:

1. Place the receiving antenna in a separate location or orientation.
2. Ensure a greater distance is achieved between the receiver and the equipment.
3. Ensure that your equipment is connected to an outlet on a separate circuit than the receiver.
4. Contact a technician experienced with radio and TV or a dealer for further assistance.

Declaration of Conformity Request

Units labeled with a CE mark comply with the following standards and directives:

- Harmonic Standards: Low Voltage Directive EN 62040-1 1st / IEC 62040-1 1st and EMC Directive EN62040-2 1st / IEC 62040-2 1st
- EU Directives: 73 / 23 / EEC, Council Directive on equipment designed for use within certain voltage limits

2006 / 95 / EC, Amending Directive 93 / 68 / EEC and 73 / 23 / EEC

89 / 336 / EEC, Council Directive relating to electromagnetic compatibility

2004 / 108 / EC, Amending Directive 92 / 31 / EEC and 89 / 336 / EEC relating to EMC

The EC Declaration of Conformity is available upon request for products with a CE mark.



IMPORTANT SAFETY INSTRUCTIONS

SAVE THESE INSTRUCTIONS



1. This manual contains important instructions that should be followed during Installation and Maintenance of the UPS and Batteries.
2. **CAUTION (UPS with Internal Batteries):** Risk of electric shock - Hazardous live parts inside this unit are energized from the battery supply even when the input AC power is disconnected.
3. **CAUTION (No User Serviceable Parts):** Risk of electric shock, do not remove cover. No user serviceable parts inside. Refer servicing to qualified service personnel.
4. **CAUTION (Non-isolated Battery Supply):** Risk of electric shock, battery circuit is not isolated from AC input / output; hazardous voltage may exist between battery terminals and ground. Test before touching.
5. **WARNING (Fuses):** To reduce the risk of fire, replace only with the same type and rating of fuse.
6. **WARNING:** Intended for installation in a controlled environment. The maximum ambient temperature is 40°C.
7. **CAUTION:** Do not open or damage the battery, electrolyte may be released which is harmful to the skin and eyes.
8. **CAUTION:** A battery can present a risk of electric shock and high short circuit current. The following precautions should be taken when working with batteries:
 - a. Remove watches, rings and other jewelry or metal objects.
 - b. Use only tools with insulated handles.
 - c. Wear rubber gloves and boots.
 - d. Do not lay tools or metal parts on top of batteries.
 - e. Disconnect charging source prior to connecting or disconnecting battery terminals.
9. Do not dispose of batteries in a fire, as they may explode.
10. To reduce the risk of electric shock, disconnect the UPS from the AC input power supply before installing a communication interface cable. Reconnect the power cord only after communication interconnections have been made.
11. Battery replacement should be performed or supervised by personnel with knowledge of batteries. Keep unauthorized personnel away from the batteries.
12. **CAUTION:** To reduce risk of fire, connect only to a circuit provided values as shown in table below, maximum branch circuit over current protection in accordance with the National Electric Code, ANSI/NFPA 70". An AC output disconnect shall be provided by others. Table 3a for UL models and Table 3b for CE models.

CAUTION: This UPS is not applicable for motors, hair dryers, speakers, and fluorescent lamps.

The instructions contained within this safety manual are extremely important and should be closely followed at all times during installation and follow-up maintenance of the UPS and battery.



CAUTION

The unit contains dangerous voltage levels. If the UPS is on, but not connected to an AC power supply, the unit's outlets may still be energized with voltage due to the presence of an internal power source, i.e. the battery.

The unit should be installed indoors in an area free of electrically-conductive contaminants.

The unit should be installed in a temperature and humidity controlled environment in order to reduce the risk of electric shock.

Only the power cord that is supplied with the unit should be used to connect it to the AC power supply. The equipment should also be located as close as possible to the AC supply.

Replacing and maintenance should only be carried out by qualified service personnel with the exception of battery replacement.

Before carrying out battery or fuse replacement or shipping the unit, first ensure that the unit is turned off completely and all cables are disconnected.

For additional safety instructions, please use the Safety Manual as reference.

Symbols

The following symbols warn of precautions and provide directions or instruction regarding the unit:



RISK OF ELECTRIC SHOCK - Indicates that there is a risk of electric shock.



CAUTION: REFER TO OPERATOR'S MANUAL - Indicates that the operator's manual should be referred to for additional information, such as operating and maintenance instructions.



SAFE GROUNDING TERMINAL - Indicates primary safe ground.



LOAD ON/OFF - Indicates that the associated push-button turns the unit and its output on or off.



RJ-45 CONNECTOR - Indicates that this connector provides network interface connections and that telephone or telecommunications equipment should NOT be plugged into it.



DISPOSAL - Indicates that the UPS and its batteries should be disposed of in the correct manner since the batteries are of the lead-acid type. It is recommended that the batteries be recycled.

1. Introduction

The information provided in this manual covers single phase 6000 – 10000 VA, uninterruptible power systems, their basic functions, operating procedures, and emergency situations, also including information on how to ship, store, handle and install the equipment. Only detailed requirements of the UPS units are described herein, and installation must be carried out in accordance with this manual. Electrical installations must also carefully follow local legislation and regulations. Only qualified personnel should conduct these installations as failure to acknowledge electrical hazards could prove to be fatal.

2. System Description

Several different kinds of sensitive electrical equipment stay protected by a UPS (Uninterruptible Power System) including computers, workstations, process control systems, telecommunications systems, sales terminals, other critical instrumentation, etc. The purpose of the UPS is to protect these systems from poor quality utility power, complete loss of power, or other associated problems.

Electrical interference abounds in many forms causing problems in AC power, from lightning, power company accidents and radio transmissions to motors, air conditioners, and vending machines, among others. So protection of sensitive electrical equipment is vital to protect against power outages, low or high voltage, slow voltage fluctuations, frequency variations, differential and common-mode noises, transients, etc.

In order to prevent power line problems reaching critical systems causing damage to software, hardware and causing equipment to malfunction, the UPS helps by maintaining constant voltage, isolating critical load output if needed, and cleaning the utility AC power.

2.1 General Description

As a double conversion on-line UPS, it is able to supply uninterrupted, clean single-phase power to your critical systems while keeping batteries charged continuously, regardless of whether utility power fails or not.

In event that a power failure lasts longer than a UPS backup time, it will shut down avoiding battery discharge, and as soon as voltage comes back, the UPS will automatically charge up and start recharging the batteries. As shown in Fig.1 block diagram:

- An input filter reduces transients on the mains
- For maintaining full battery charge, AC-power is rectified and regulated in the rectifier feeding power to the inverter and battery converter.
- DC power is converted to AC in the inverter passing it on to the load.
- Power is maintained from the battery during a power failure.
- The converter increases voltage appropriately for the inverter.

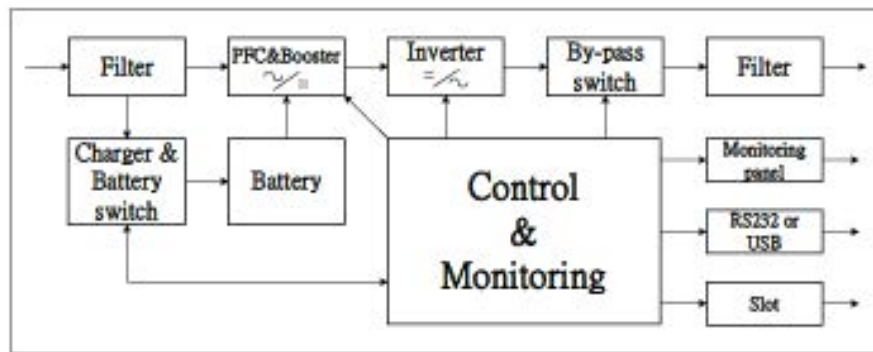

Efficiency Optimizer Function

The Efficiency Optimizer function is a new feature for the UPS adding cost effectiveness, minimizing power loss and reducing power consumption. Alternating between bypass and on-line modes is achieved automatically and in accordance with the conditions of the utility power. On-line mode may be used during times of intermittent power supply, and bypass mode when power flows smoothly in order to obtain greatest efficiency. Irregularities can be detected in less than a second, and on-line mode reactivated immediately. Switching back to online mode occurs when input voltage is outside $\pm 10\%$ or nominal ($\pm 15\%$ selectable), when input frequency is outside of $\pm 3\text{Hz}$ or when no input line is available. Although high efficiency is standard, the default operation is in on-line mode. Bypass can be activated in the LCD panel, though on-line can be run permanently if preferred.

Free Run Mode

The UPS operates in free run mode when input frequency is outside of the selected input frequency range. Free run mode is when output frequency does not match input frequency. When starting the UPS, the frequency regulation detected is 50 or 60 Hz $\pm 0.25\text{Hz}$. Please refer to chapter 7.2 if you want bypass available while running in free run mode.

Diagnostic Tests

When you start the UPS, a diagnostic test is automatically executed that checks electronics, battery, and reports any problems on the LCD display. An advanced battery management system always monitors the conditions of the batteries sends any forewarnings if replacement is needed. Otherwise every 30 days of normal mode operation, a battery discharge test is performed and any problems reported on the LCD display. Except during the first 24 hours after startup while the UPS is in charging mode (please see chapter 7.2), diagnostic tests can be performed manually from the front panel at any time.

2.2 System Configuration

The UPS device and the internal backup battery make up the system. Depending on the site and load requirements of the installation, certain additional options are available as a tailored solution. Planning a UPS system, the following should be taken into consideration:

- The total demand of the protected system shall dictate the output power rating (VA). Allow a margin for future expansion or calculation inaccuracies from measuring power requirements.
- Backup time needed will indicate the battery size needed. If load is less than the UPS nominal power rating then actual backup time is longer.
- The following options are available:
 - ◆ External Battery Cabinets
 - ◆ Transformer cabinets
 - ◆ Maintenance bypass switches
 - ◆ Connectivity options (relay card, SNMP/WEB card)

The following UPS models are available

Model	Backup time with internal batteries	Recharge time to 90% capacity
6000VA	4~6min	4 hours
10000VA	3~5min	4 hours

Note the battery backup times are approximate and could vary depending on battery life and temperature configuration.

Additional External Battery Cabinets are available if more back-up time is needed.

3. Safety information

Information presented here is vital to all personnel and please also read the UPS safety manual.

Storage and Transportation

Please handle with extreme caution since a high amount of energy is contained with the batteries. Always keep the unit in position as marked on the packaging and never drop the unit.

Installation

If flammable substances such as gases or fumes are present or if the room is airtight, a safety hazard situation exists, in which no electrical equipment should be operated. The instructions in this manual explain how to install the UPS safely. Not acknowledging such electrical hazards may be fatal, so keep this manual for all future reference.



Warning

It is strongly advisable not to open the UPS cabinet as the components have very high voltage and touching them may be fatal. Only a technician from the manufacturer or an authorized agent may service the unit. This UPS unit's output receptacles carry live voltage even when not connected to a power supply as it has its own energy source.

User's operations - The only operations that users are permitted to do are:

- Turning the UPS unit on and off
- Operating the users interface
- Connecting data interface cables

All such operations are to be performed exactly as instructed in this manual. The greatest care possible must be taken for any of these operations and any change thereof may prove very hazardous to the operator.

4. Storage

Please adhere to the following instructions if the UPS is not installed immediately:

- Store the equipment as is in its original packing and shipping carton
- Do not store in temperatures outside the range of +15°C to +25°C.
- Ensure that the equipment is fully protected from wet or damp areas and from moist air.

In order to maintain the vitality of the batteries, ensure that the UPS is recharged every 6 months for at least 8 hours.

5. Installation

5.1 Environment

Ensure that all environmental requirements are met, otherwise the safety of installation personnel and users cannot be guaranteed. In addition, the unit may sustain damage or malfunction.

Please adhere to the following environmental instructions when locating the UPS and EBP's:

1. Avoid temperature and humidity extremes. The optimum operating temperature range is between 59°F and 77°F (+15°C and +25°C).
2. Provide protection against moisture or avoid altogether if possible.
3. Ensure there is at least 12 inches (300mm) behind and 12 inches (300mm) on each side of the UPS for ventilation.
4. Ensure that the front of the UPS remains unobstructed for access to the control panel and LCD display.
5. External Battery Packs must be installed next to or under the UPS.

Caution! The UPS and the External Battery Pack are to be installed at the same location. In case, the UPS and the External Battery Pack are installed outside of visible distance, then subject to the local inspection authority, User will need to add a Safety disconnect adjacent to the UPS to provide safety isolation.

5.2 AC Power and Load Connections

Vertical and Wall-Mount Installation

Only qualified technicians should carry out installation of this equipment. The installation must further comply with all local legislation and regulations.

Follow all installation and safety instructions very carefully to avoid the existence of a hazardous situation and damage to the UPS and/or loads.

The high voltage and current contained within this equipment can injure or be fatal to personnel and can damage associated equipment.

Various input (and sometimes output) cables are supplied with all models:

1. Ensure that the UPS is disconnected from the AC supply when connecting External Battery Packs.
2. Use the battery cable that is supplied with the External Battery Pack when connecting it to the UPS. Connect the second battery cabinet to the first and so forth, assuming more than one is to be used.
3. Take note of UPS parameters when adding external battery packs and adjust accordingly (see Ch. 7).
4. Connect the input cable to the UPS and connect the other end to a grounded AC power supply. The batteries will automatically begin to charge. Please note that while the UPS may be used immediately, maximum back-up time may not be available until the batteries have been charged for a minimum of 8 hours. See Table 1 for input circuit breaker rating and conductor size.
5. If the unit displays "Site Wiring Fault", have the wiring fault corrected or alternately, disable the related alarm on the UPS.
6. After initial charging is complete, connect the loads to the UPS.
7. Do not connect any load that may overload the UPS such as equipment containing AC electric motors or loads that have a high inrush current.
8. Make computer and/or alarm interface connections according to Chapter 6 of this user manual and that provided with the interface option. These connections are made on the rear panel.
9. Installation is now complete.

Table 2

Power for UPS	Circuit Breaker	Wiring AWG or mm ²
6000VA	40A	10 AWG or 5.5mm ²
10000VA	60A	8 AWG or 8 mm ²

Additional Installation Information (for 6kVA - 10kVA Models)

1. Ensure that all electrical connections have been correctly implemented for the installation site out.
2. Refer to Table 2 for input and output breaker rating.
3. Isolate and prevent the source from activating. Both input and output circuit breakers (located on the rear of the unit) must be in the "OFF" position.
4. Refer to figure 2 for single cable input connection and figure 3 for dual cable input connection. If installing dual cables, the interconnection jumper (J) shown in figure 2 needs to be removed.
5. If during installation, it cannot be determined that the neutral is grounded or identification of the status of the neutral in the AC supply is unreliable, an additional two pole disconnect device may be necessary in the for the installation.
6. Should the optional Emergency Power Off (EPO) circuit on the rear on the unit be used, the output of the UPS will shut down immediately.

Note: Local safety requirements may require a separate external Emergency Power Off that opens output circuit breakers. Refer to local wiring regulations.

Table 3a

UPS Model	Input Breaker Rating	Output Breaker Rating
6kVA	2P, 250Vac, 40A	2P, 250Vac, 40A
10kVA	2P, 250Vac, 60A	2P, 250Vac, 60A

Fig. 2

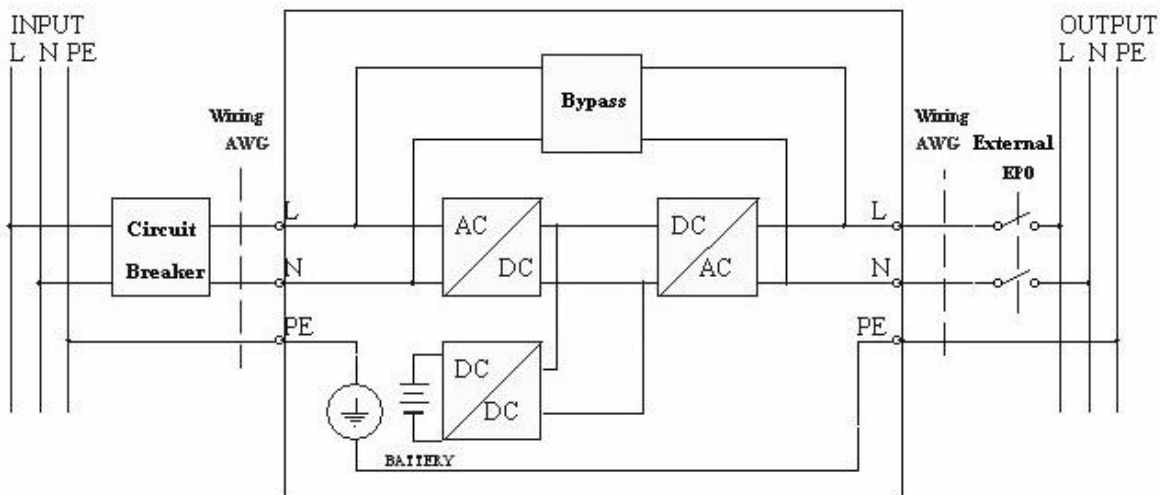

Installation Appendix

Installing the input /output terminals with covers on UPS Module. Screws: M3x8

Step 1: Separate the top cover

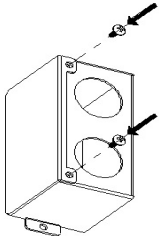

Step 2: Fix the bottom cover on the terminal block.

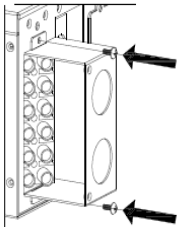

Step 3: Input configure. Insert the input cable.

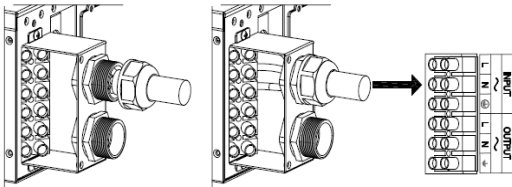

Step 4: Output configure. Insert the output cable.

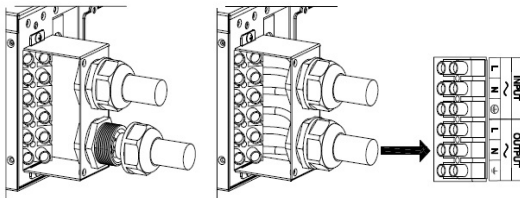

Step 5: Fix the top cover.

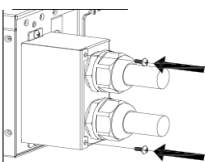

Connecting the UPS to the Battery

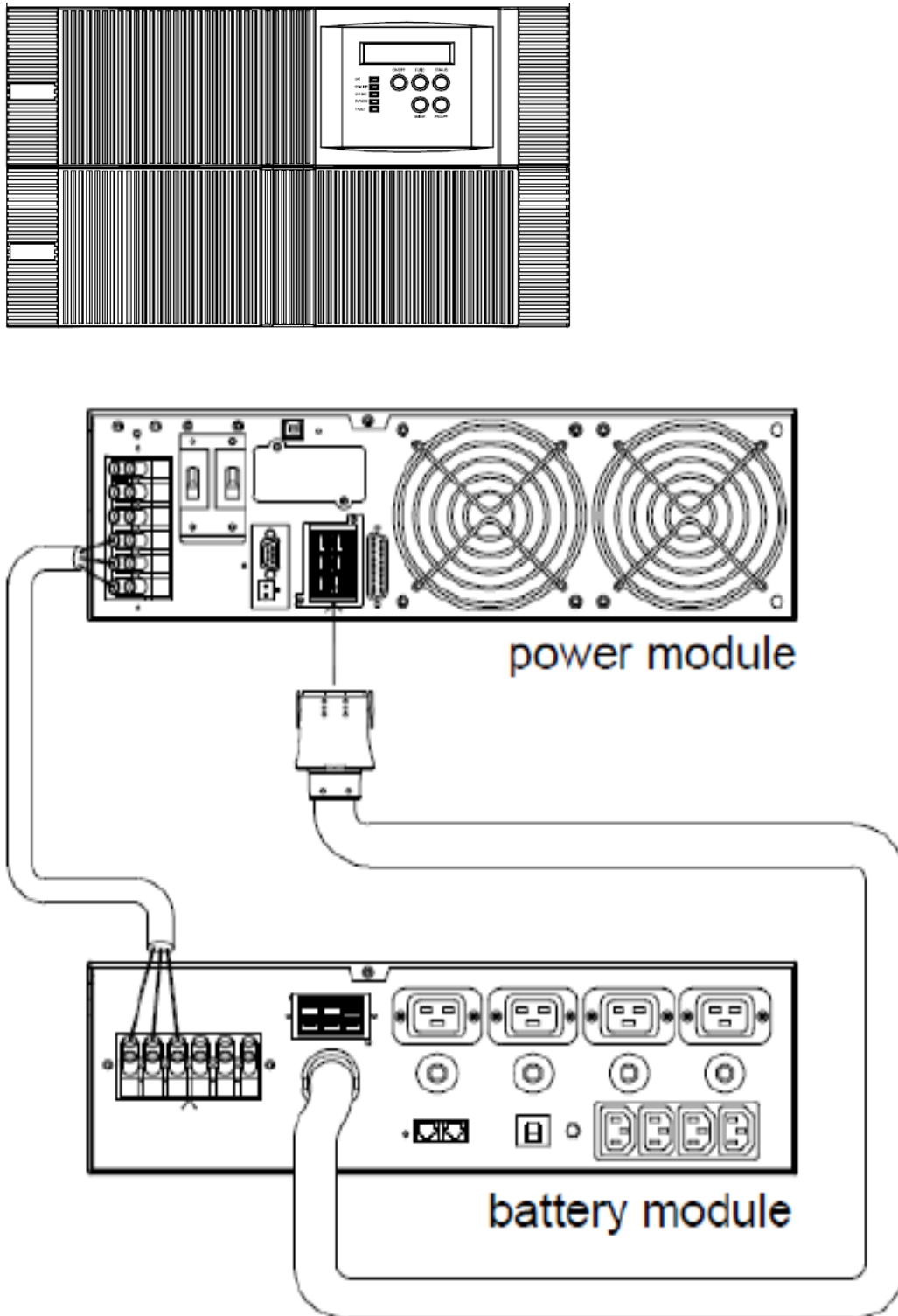

Unit Stack Installation

The following diagrams illustrate how to stack the units (and battery packs when applicable).

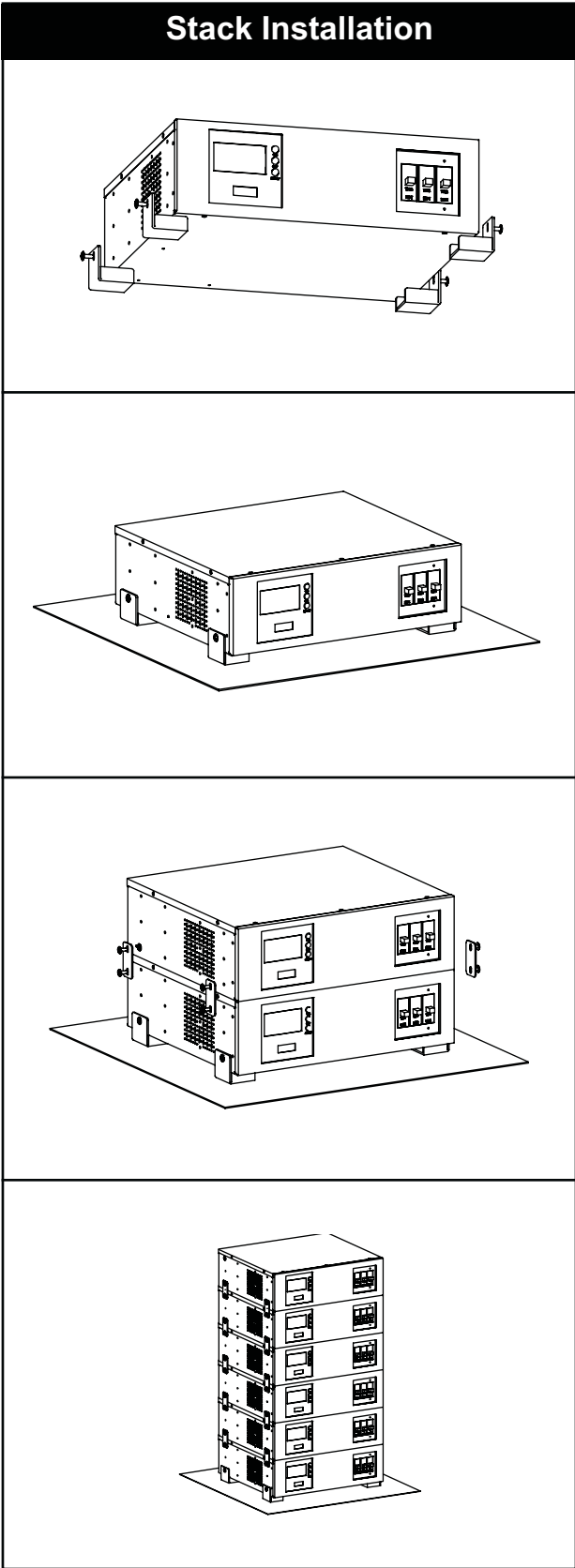

5.3 Rear Panel Views

1. 6000VA Tower Rear Panel

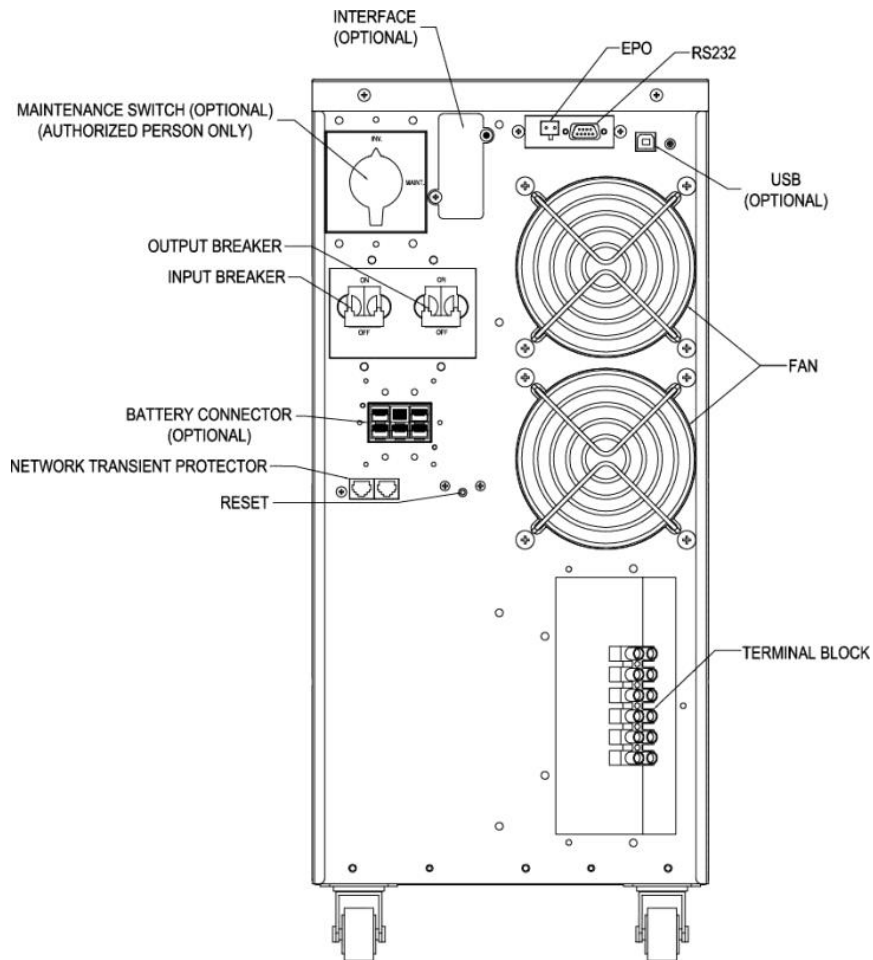

2. 6000VA RT Rear Panel

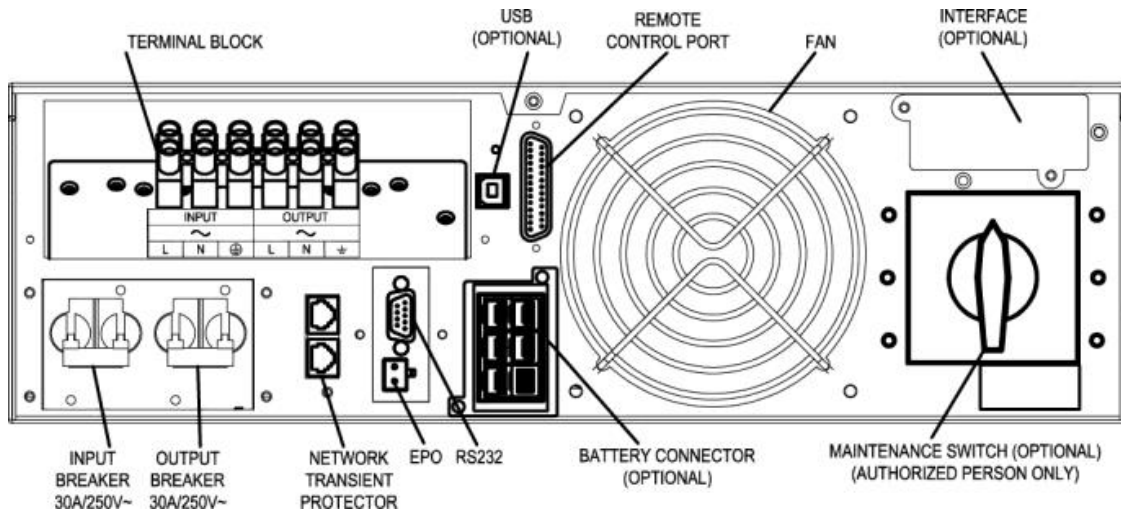

3. 10000VA Tower Rear Panel

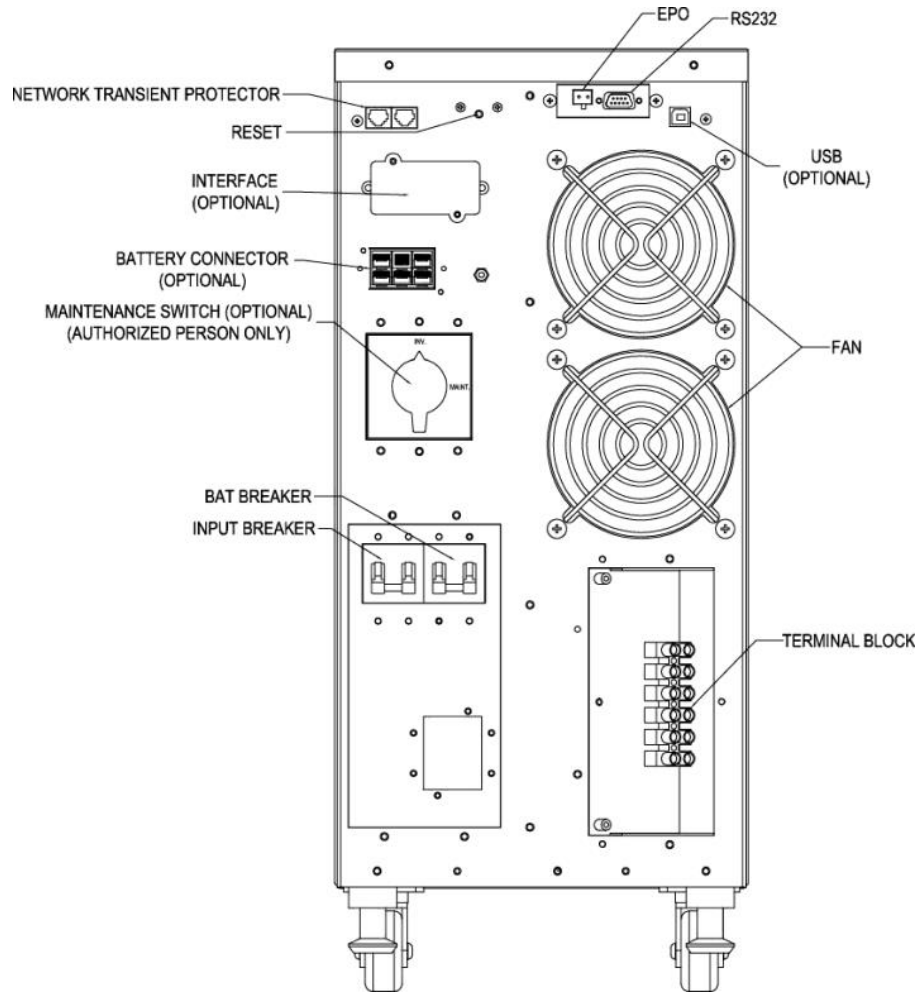

4. 10000VA RT Rear Panel

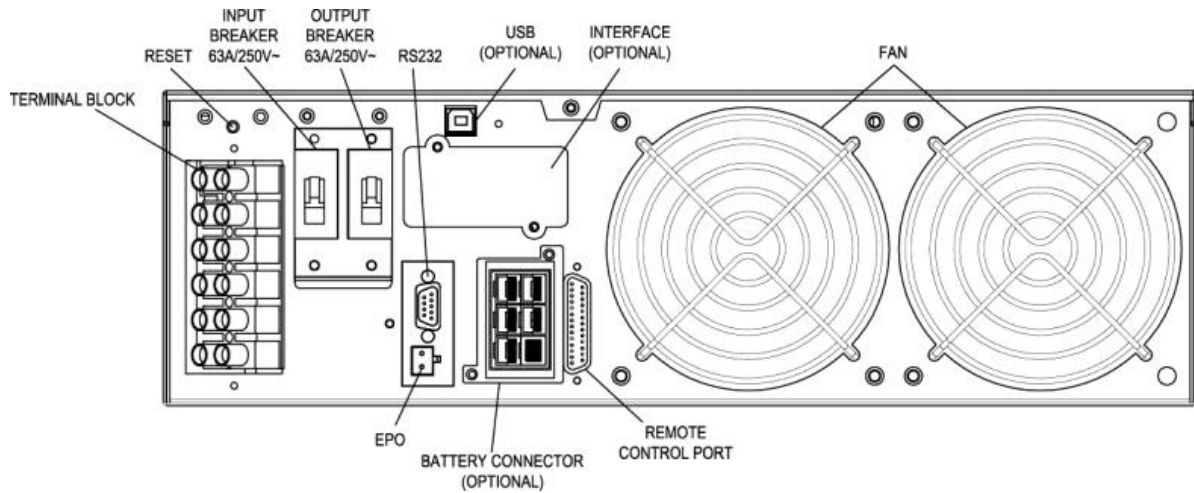

5.4 Connection to Mains and Loads (6000 - 10000VA)

Only qualified specialists or technicians who conform to applicable safety standards may carry out the installation of this equipment. The installation must further comply with all local legislation and regulations.

Follow all installation and safety instructions very carefully, otherwise those performing installation may suffer from a hazardous situation and the UPS or load connections may also be damaged.

CAUTION:

This UPS is not applicable for motors, hair dryers, speakers, and fluorescent lamps.

The high voltage and current contained within the UPS equipment can injure or kill personnel and damage equipment.

For electrical installation, closely observe the nominal current rating of the source.

Installing External Battery Cabinets

First disconnect the UPS from mains and loads before attempting an External Battery Cabinet installation.

- Use the battery cable provided with the External Battery Cabinet to connect the External Battery Cabinet to the UPS. Connect a second battery cabinet to the first one with the cable provided if more than one is to be installed.
- Be aware of UPS parameters and changing the Battery pack quantity when using the external battery cabinets (see chapter 7.2)

Installing UPS

- Ensure that the installation site has all electrical connections properly carried out. In addition, refer to figures 2 to 4 to check the fuse and cable dimensions.
- Isolate and secure the source against re-closing. Both input and output circuit breakers (located in the back) must be "OFF".
- Refer to figure 2 to 4 for single cable input and figure 2 to 4 for dual cable input. Connect the UPS according to these diagrams. If installing dual cables, the interconnection jumper (b*) needs to be removed as in figure 2 to 4. Fuse and cable sizes are given in figure 2 to 4.
- During installation, if it cannot be determined that neutral is grounded or the identification of the neutral status of the mains supply is unreliable, an additional two pole disconnect device is necessary in the building installation.
- At the back of the unit you will find the Emergency Power Off (EPO), which when open will immediately shut down the logic circuit output of the UPS as in figure 2 to 4. Wiring the EPO signal is optional.

Caution! Local safety requirements may require a separate external Emergency Power Off that opens output circuit breakers, and if so, use figures 2 to 4 for proper installation. Refer to local wiring rules.

- Should computer or alarm connections be used, use connections according to chapter 6 of the manual provided with that option. The connections can be referred to on the rear panel.
- The installation is now complete.

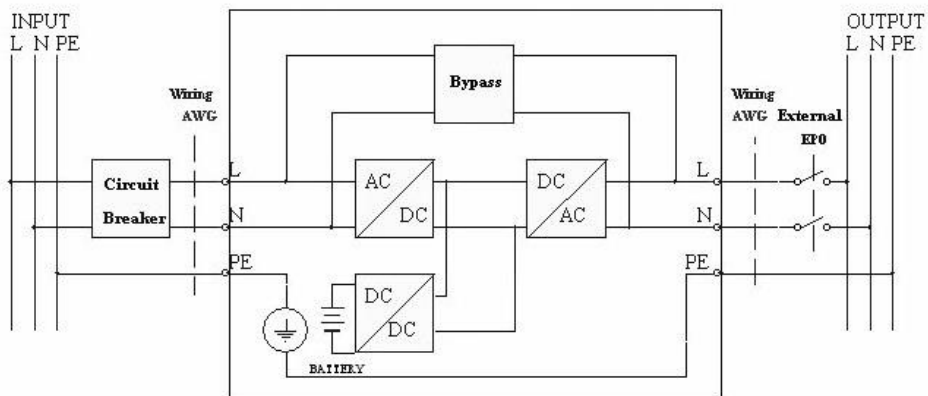

Power for UPS	Circuit Breaker	Wiring AWG or mm ²
6000VA	40A	10 AWG or 5.5mm ²
10000VA	60A	8 AWG or 8 mm ²

Fig. 2

5.5 Default Settings at the Factory

On the LCD display you will find several of the UPS parameters to select. Default settings are as follows:

Settings	Selection	Factory default
Output Voltage Setting	208/220/230/240 Vac	230V (FOR HV series)
Input/Bypass Voltage	±10% +10/-15% +15/-20%	+10/-15%
Input/Frequency	±2% ±5% ±7%	±5%
HE Mode Setting	On/Off	Off
Free Run Mode	On/Off	On
Bypass Enable/Disable at free run mode	Disable/Enable	Disable
Alarm silence	On/Off	Off
Site wiring alarm	Enable/Disable	Disable
External Battery pack setting	0, 1, 2	0

You may change default settings, but we recommend that this is done after installation and before starting up loads. Read UPS configurations in chapter 7.2 for more information.

6. Computer and Alarm Connections

At the back of the UPS is an interface allowing direct communication with your computer system, the location of which can be found in figure 4. There is a RS232 serial data interface, one USB data interface and an emergency power off switch supplied. However, the RS232 port cannot be used when the USB interface is in use, as USB port has the absolute priority than RS232. In addition there is an optional interface slot that allows you to install different communications cards. It can be used parallel with either the RS232 or USB ports. Currently there are two cards available for the optional interface slot. An SNMP/WEB card allows management and monitoring over a network or Internet, and the AS/400 card allows voltage free relay contacts. Your local dealer will have more information about these option cards.

Connecting the UPS to a Computer

The communication device for the UPS and PC comes as a complete package with power management software. Only the communication cable provided with UPS may be used to connect to your computer, which is accomplished through the UPS RS232 port. Also ensure that the operating system on your computer is supported. Instructions provided in the power management software will help with this installation. Other advanced power protection solutions such as SNMP are provided by your dealer.

RS-232 Standard Interface Port

The RS-232 interface uses a 9-pin female D-sub connector, consisting data about utility, load and the UPS. The interface port pins and their functions are identified in the following table.



Pin #	Signal name	Direction (re UPS)	Functions
2	TxD	Output	TxD Output
3	RxD	Input	RxD / Inverter Off Input
5	Common		Common
6	CTS	Output	Ac Fail Output
8	DCD	Output	Low Battery Output
9	RI	Output	+12 VDC Power

Caution! Max rated values 12Vdc/50mA

Fig. 4

USB Port (option)

Connecting the UPS to your computer is accomplished through the USB port on the back of your computer. USB compliant hardware and operating system will be necessary including installation of a UPS driver. The serial port cannot be used when using the USB port. The USB cable is standard and can be bought separately.

6.1 EPO Port (emergency power off)

A customer-supplied switch located remotely can be used to open the EPO connection and allows UPS output receptacles to be switched off. Since the EPO shuts down the equipment immediately, orderly shutdown procedures are not followed and not by any power management software. The UPS will have to be manually restarted in order to regain power to the outlets.

6.2 Network Transient Protector (Optional)

The network transient protector, located on the rear panel, consists of both IN and OUT jacks housed on a separate RJ-45 (10BaseT) network card. If used, make sure that the input and the output are connected to the appropriate jack.

6.3 Load Segments (Where applicable)

The power management software controls individual sets of output receptacles on the UPS called "load segments" which provide controlled and sequential startup and shutdown of loads. Less critical equipment can be turned off during power outages saving battery power for more critical loads. Load segment status can be viewed from the LCD display on the UPS and can be changed if necessary. Load segments are usually controlled by the UPS management software.

7. Operational Instructions

7.1 Starting Up and Shutting Down the UPS

Start Up

1. Ensure that the unit has been correctly installed and that the input power cable is connected to a properly grounded AC outlet.
2. The unit is turned on by pushing the power push-button on the front panel for more than 3 seconds.
3. The unit sequences through its functional check, AC line synchronization and inverter startup. Power is then applied to the outlets.
4. During this sequence, the LCD panel displays "Ready On". An LED illuminates when output power is available and the LCD panel displays "Line mode".
5. The loads can now be turned on.

Shut Down

1. Shut down and turn off all connected loads.
2. Push the power push-button on the front panel for five seconds or more. An audible alarm will sound and the unit will shut down.
3. The LCD panel displays "UPS OFF" for a few seconds.
4. In emergency situations or applications which require such, the EPO located on the back of the unit should be used.

7.2 Push-button Operations

There are five operational push-buttons on the front panel:

1. **ON/OFF** - This push-button turns the unit on and off. To initiate a start-up or shut-down, press and hold this push-button for 3 seconds.
2. **STATUS** - This push-button is used to check current UPS and load settings, information and power measurements. To activate, press it for at least 2 seconds. There are 15 different functions that can be checked in this mode and pressing this push-button once each time scrolls through each function. If the push-button is not pressed within 10 seconds, the display reverts to its original mode.
3. **FUNC** - This push-button selects or enables various user-selectable parameters. There are 14 different parameters which can be scrolled through. To activate, press it for at least 2 secs. After locating a setting or particular parameter, press the Enter push-button to select that parameter and view its current setting. Press the Function push-button once again to scroll through the setting options. Once the desired setting is located, press the Enter push-button to enable the new setting and once again to save it (you will be prompted to do so). If no action is taken within 10 seconds, the display reverts to its previous mode.
4. **ENTER** - This push-button is used to enter, enable and/or confirm a selected function.
5. **ESCAPE** - This push-button is used to exit a menu and return to the main display.

7.3 Control Panel Indicators

Status, parameters and readings are displayed on the control panel via five LED indicators and/or an LCD screen and audible alarms compliment the display.

- ON**  This symbol is accompanied by a green LED that illuminates when the UPS has been turned on.

- ON-LINE**  This symbol is accompanied by a green LED that illuminates when the UPS is in normal or static bypass mode and AC voltage is present at the output terminals.

- ON-BAT**  This symbol is accompanied by a yellow LED that illuminates when the UPS is operating in battery mode.

- BYPASS**  This symbol is accompanied by a yellow LED that illuminates when the UPS is operating in bypass mode.

- FAULT**  This symbol is accompanied by a red LED that illuminates if an internal UPS error occurs. An audible alarm also sounds but can be muted by pressing any of the push-buttons on the front panel.

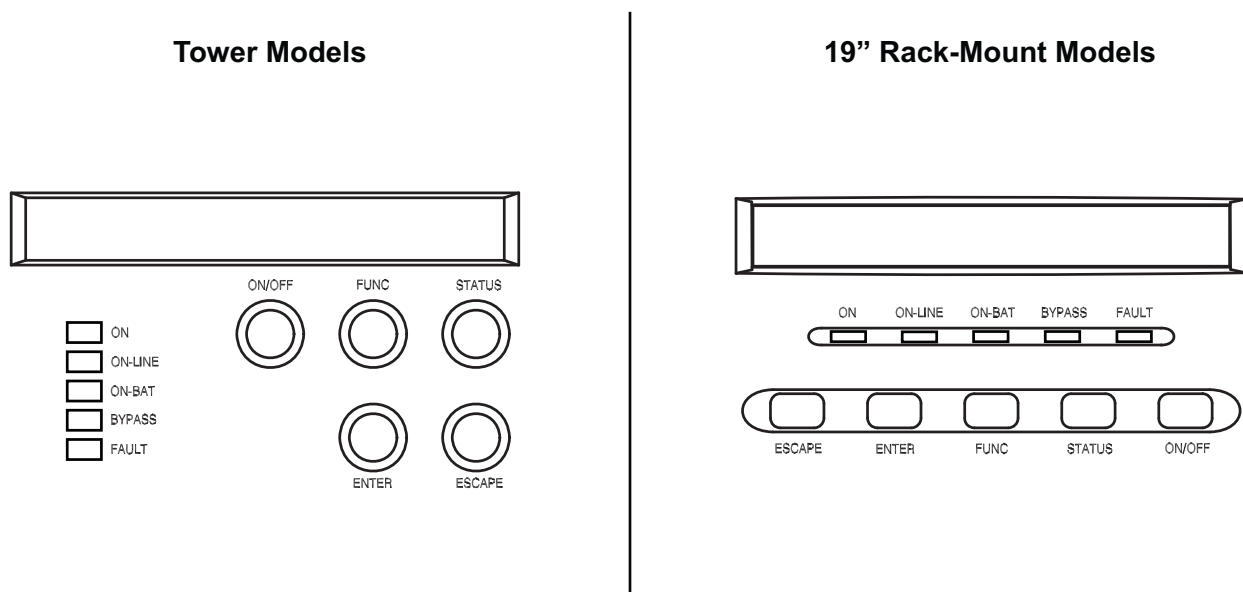

Fig. 5 Control panel

7.4 LCD Panel Display Modes

1. Normal Display Mode

UPS status is shown in this display mode. From this mode, the UPS data display mode and the setting display mode can be selected by pressing the appropriate push-button.

2. Data Display Mode

Various data and measurements are shown in this display mode. Pressing the Enter push-button (for 2 seconds to activate) scrolls through the following data:

Parameter	Indicates
O/P VOLT = xxx,x V	Output AC voltage
O/P FREQ = xx,x Hz	Output Frequency
I/P VOL T = xxx,x V	Input AC voltage
I/P FREQ = xx,x Hz	Input Frequency
BAT VOLT = xx,x V	Battery Voltage
O/P LOAD% = xx %	Load expressed as a percentage of the maximum load
O/P W = x W	Output Watts
O/P VA = x VA	Output VA
O/P CURR = x A	Output Current
BACKUP TIME = xx min	Estimated Backup time in minutes
BAT CHARG = xx %	Approximate Battery capacity expressed as a percentage
TEMPERATURE = xx °C	Approximate ambient temperature
BAT PACK NUM = x	External Battery Pack quantity
RATING = xxxx VA U	UPS Rating
CPU VERSION = xx.x	CPU Version

3. Configuration/Setting Display Mode

1. The current UPS configuration/settings are shown in this mode.
2. To enter this, press the Function/Scroll push-button for two seconds. The first configuration parameter will be shown on the LCD display.
3. Press the Function/Scroll push-button to scroll through each parameter.
4. Press the Enter push-button to select the parameter.
5. Press the Function/Scroll push-button to scroll through the options for the selected parameter.
6. Press the Enter push-button to select the option. You will be prompted to save the selection, so press the Enter push-button to confirm and save your selection. See the table below for further details.
7. If no action is taken within 10 seconds, the display reverts to normal display mode.

Settings	LCD Display	Detail	Selection/Option Default	
Output Voltage	O/P V Setting	Nominal Voltage Selection	208/220/230/240V	230V
Input / Frequency	I/P F Setting	Input frequency range selection when UPS is in free run mode	±2% ±5% ±7%	±5%
Input / Bypass Voltage	I/P Bypass Set	Input Voltage range selection when bypass is available	±10% +10/-15% +15/-20%	+10/-15%
Free Run Mode <ul style="list-style-type: none"> Bypass Enable / Disable in Free run Mode 	Free Run Set	UPS run in Free run mode selection (unsynchronized)	ON / OFF	ON
	Bypass disable	Allows the UPS to go into bypass mode when unsynchronized	Disable / Enable	Disable
High Efficiency Mode	HE Mode Set	Allows the UPS to run in high efficiency mode	ON / OFF	OFF
Manual Bypass Force	Manual Bypass	Forces the UPS into bypass mode. (For service only)	ON / OFF	OFF
Load Segment / Group Management	Outlet Setting	Allows load group/segments to be turned on and off from the front panel	1 ON & 2 ON 1 OFF & 2 ON 1 OFF & 2 OFF 1 ON & 2 OFF	ON & ON
Initiate Battery Test	Battery Test	Detects whether battery is in good condition or not.		
Alarm Silence	Silence Set	Enables or disables alarm silencing	ON/OFF	OFF
External Battery Pack Quantity	Bat Cabinet Set	Allows the UPS to more accurately determine remaining backup time	0 (only internal batteries) 1 (1 external cabinet) 2 (2 external cabinets)	1
Site Wiring Fault Alarm	Sit Fault Set	Enables or disables site wiring fault alarm	Enable /Disable	Disable
Language	Language	Selects load language	English, German, French, Spanish, Italian	English
Generator Mode <ul style="list-style-type: none"> Bypass Enable / Disable in Free run Mode 	Generator	Places UPS in generator mode ***	ON / OFF	OFF
	Bypass disable	Allows the UPS to go into bypass mode when unsynchronized	Disable / Enable	Disable
RS-232 communication	RS232 Control	Enables or disables RS-232 communication capability	Enable / Disable	ENABLE

7.5 Manual UPS or Battery Test

A manual UPS or battery test can be initiated from the UPS configuration/settings display and can be carried out even when the UPS is not charging the battery. To initiate, scroll through the parameters until Manual Bat test is displayed on the LCD panel. Press the Enter push-button twice.

** NOTE: In order for the UPS and power management software to function correctly, Manual Bypass should always be set to OFF as the load will not be protected by the UPS when Manual Bypass is ON.

*** NOTE: The UPS should be turned off but kept connected to the AC power supply before activating the Generator Mode.

7.6 Sense Mode - Normal and Generator Waveforms

This is used to broaden the input parameters to accommodate the voltage fluctuations created by a backup generator or a noisy line. The factory default setting is normal, where the unit runs on normal parameters. Switching to Generator makes it run on noisy generator parameters. If the unit constantly switches between line and battery modes due to a noisy line, select generator mode to prevent unnecessary transfers I returns. In generator mode, the acceptable range of input frequency and voltage is expanded to accommodate the voltage and frequency fluctuations created by a generator or a power source of such kind. Use a generator with electronic speed and voltage controls which typically produces Total Harmonic Distortion in % (THD) of less than 10%. Generators with mechanical governors can force the system to run continuously in Battery mode.

Before installation, compare the generator's output voltage to the UPS's input voltage requirements as listed on both nameplates. To insure the system's smooth operation, use a generator capable of supplying 2X or twice as much power as required by the total load.

7.7 Audible Alarms

1. If the UPS is on battery and the "ON BATTERY" LED is illuminated, the unit will beep every 5 seconds.
2. If the battery capacity is low and the "ON BATTERY" LED is flashing, the unit will beep twice every 5 seconds.
3. If the UPS is in bypass mode and the "BYPASS" LED is illuminated, the unit will not beep.
4. If the UPS has an internal fault and the "ALARM" LED is illuminated, the unit will emit a constant alarm tone and display the cause of the fault on the LCD panel.
5. To silence an alarm, press any of the three push-buttons on the front panel. The alarm will be silenced under all conditions except when the battery is low, under which condition the alarm cannot be silenced.
6. The audible alarm function can be de-activated internally by selecting the appropriate parameter from the LCD panel.

7.8 Troubleshooting

LCD	Alarms	Problem Description	Corrective Action
Output Overload	Two beeps per second	The UPS is overloaded (in Line Mode). The power rating of the connected equipment exceeds the capacity (VA rating) of the UPS. The UPS operates in bypass mode.	Reduce the load on the UPS by disconnecting less critical equipment. Once the total load is below the maximum specified by the UPS, it will switch from bypass back to normal mode.
Battery Test	No audible tone	The UPS is performing a battery test.	No action required. The UPS will resume normal operation once the battery test has been successfully completed.
Over-Charge	Constant audible tone	The batteries have been over-charged.	Turn off protected loads, then turn off the UPS and contact tech support.
Low Battery	Two beeps every 5 seconds	The unit is operating on battery power but will shut down shortly due to low battery voltage.	Initiate a controlled shutdown of connected equipment immediately. The UPS will restart automatically once AC power has been restored.
On-Battery	One beep every 5 seconds	The unit is operating on battery power.	No action required. A controlled shutdown of connected equipment can be initiated if necessary.
Charger Failure	Constant audible tone	Battery charger failure.	Turn off protected loads, then turn off the UPS and contact tech support.
Over-Temperature	Constant audible tone	High ambient temperature.	Check that the UPS cooling fans and ventilation holes are not blocked. Check that the ambient temperature surrounding the UPS is not above 104°F (40°C). If these conditions do not exist but the problem persists, contact tech support.
Output Short Circuit	Constant audible tone	Output short circuit.	Turn off protected loads, then turn off UPS and contact tech support.
High Output Voltage	Constant audible tone	Output voltage too high.	Turn off protected loads, then turn off UPS and contact tech support.
Low Output Voltage	Constant audible tone	Output voltage too low.	Turn off protected loads, then turn off UPS and contact tech support.
Bus Fault	Two beeps per second	Internal DC bus voltage too high.	Turn off protected loads, then turn off UPS and contact tech support.
Site Wiring Fault	One beep per second	Incorrect AC power connection polarity. Ground connection missing or faulty.	Have the wiring fault corrected or alternately, disable the related alarm on the UPS
Line Abnormal	One beep per second	Incorrect AC Line backed up during auto restart.	Connect correct AC power line.

FOR ADDITIONAL ASSISTANCE, PLEASE CONTACT US AT 310-689-2328 OR SUPPORT@MARATHON-POWER.COM

8. Maintenance

As long as all the installation, environmental and operational requirements have been followed and met, the UPS will require little or no maintenance for many years. The batteries are the only component that should eventually need replacing. Their useful life depends primarily on the following two factors; the ambient temperature of the environment in which the UPS is located and the number of times they're called into use (i.e. discharged). In both cases, the lower the number, the longer they will last. At an ambient temperature of 77°F (25°C), typical battery lifetime is 3-5 years. A test of the UPS and batteries should be carried out at regular intervals (every 6 to 12 months) to verify that back-up time is still adequate for the application. The UPS should also be charged every six months if it is kept in storage and not used.

8.1 Battery Replacement

1. For Tower Models: The batteries are all located on one side or both sides of the UPS behind a removable panel.
2. For Rackmount Models: Batteries are in a separate enclosure.
3. The UPS must be turned off completely and the loads disconnected.

Battery Type: LEAD - ACID TYPE

Battery Rating: 240 VDC, 7Ah - 9.0 Ah max.

Battery Numbers: Tower 20 or 40, Rackmount 20 PCS

The following procedure applies to all models:



WARNING! Batteries may cause electrical shock or burn from high short circuit currents. Please observe the following precautions when working with them:

1. Remove jewelry and metal objects such as watches and rings.
2. Use tools that have insulated handles.
3. Prevent tools and other metal objects from coming into contact with the batteries.
4. Batteries can pose an electric energy hazard. Do not rewire, modify, or change any battery wiring or connections. Such modifications can cause serious injury and/or damage.
5. Replace with the same type, rating and quantity as the original batteries.
6. Do NOT disconnect the batteries while the UPS is in Battery mode.
7. Remove battery grounds during installation and maintenance to reduce likelihood of shock. Remove the connection from ground if any part of the battery is determined to be grounded.
8. Risk of Electric Shock – Battery Circuit is not isolated from ac input; hazardous voltage may exist between battery terminals and ground. Test before touching.

1. The panels of the UPS can be removed by unfastening all the appropriate screws and detaching them.
CAUTION: Keep tools and hands away from the DC bus - dangerously high voltage is present!
2. Once the covers have been removed and placed out of the way, disconnect the positive (+) RED and negative (-) BLACK bus wires from the battery string, then the interconnecting cable between each battery.
3. Then remove the metal battery covers/plates/brackets and set them aside in a safe place.
4. Slowly slide each battery out from the UPS.
5. Take note of each battery's physical orientation, polarity and mechanical connections.
6. Replace the batteries and reconnect them according to the details noted in step 5.
7. Carefully replace the metal battery covers/plates/brackets making sure to avoid a short circuit with a battery or the DC bus.
8. Reinstall the panels.

Manual test of the UPS

Manual UPS or Manual Battery tests can be conducted from the UPS configuration as well and are functional even when the UPS is not charging the battery.

Manual Battery test: Scroll the parameters until Manual Bat test displays on the LCD. Press the "ENTER" button twice.

Step 1: Disassemble top cover screws, then remove the top cover.

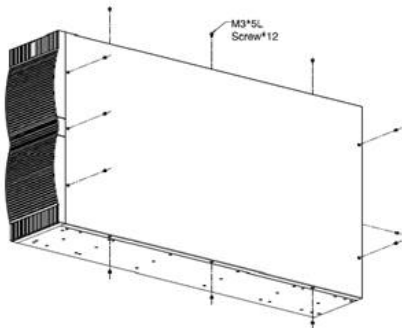

Step 2: Disassemble screws on battery tray bracket, after removing the battery tray bracket.

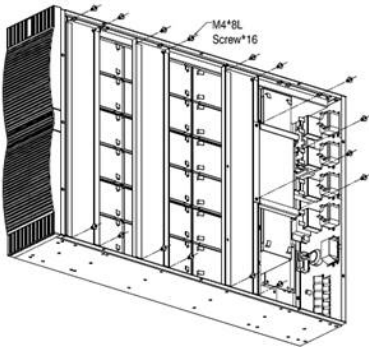

Step 3: See the configuration diagram.

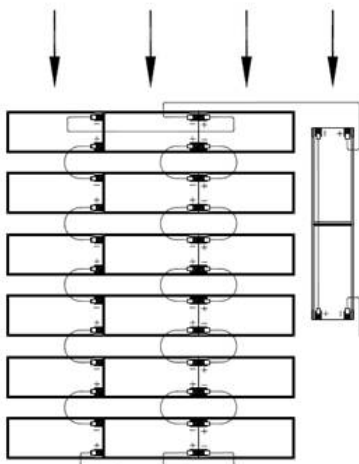

WARNING: When power supplied by external batteries, output toward loads must be limited to less than 90% of overall power generation.

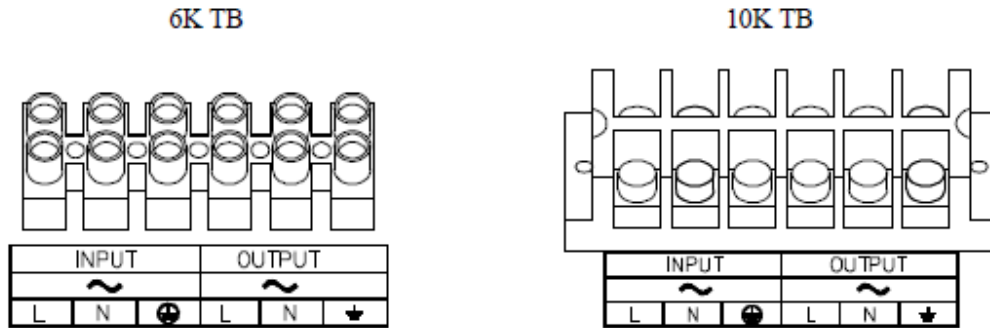

UPS Shutdown procedures:

STEP 1:

From the front panel, press and hold “ON/OFF” button to 2 seconds until hear a long beep sound and see “SHUTDOWN” on the screen. The release ON/OFF button, later you will see “UPS OFF” text appears and disappears.

STEP 2:

While display panel shows no text but only backlight, turn off input breaker.

STEP 3:

After turning off input breaker, turn off battery breaker until all fans stop to complete the shutdown procedures.

9. Technical Specifications

Tower model at PF0.9

WARNING: When power supplied by external batteries, output toward loads must be limited to less than 90% of overall power generation.

GENERAL

Rated Capacity: 6kV, 10kVA (pf. = 0.9)
Technology: True on-line, double conversion topology with integral automatic bypass

INPUT

Phase: Single phase plus ground
Input Bypass Voltage: 184 - 265 VAC (+15% to -20% of 230V nominal - user selectable)
Input Voltage range: (120 | 140 | 180VAC - 276 VAC 160-276V @ 75% load, 180V - 276V @ 100% load.)
Frequency: 50 | 60 Hz Auto sensing
AC Frequency range: 45 - 65 Hz
Synchronization range: ± 3 Hz
Input Current: 6kVA – 29A, 10kVA – 48A
Input Power factor: 0.97

OUTPUT

Output Voltage: 208 | 220 | 230 | 240 VAC (user selectable)
Voltage regulation: $\pm 2\%$
Voltage distortion: < 5% THD with non-linear loads, < 3% THD with linear loads
Frequency regulation: ± 0.25 Hz (while on battery or in free run mode)
Dynamic response: $\pm 9\%$ max from 100% to 20 % or from 20% to 100 % linear load
Overload capacity: 100 - 125% for 1 min, 126 - 150% for 10 sec
Efficiency (HE Mode): Greater than 95%
Efficiency (On-line Mode): Greater than 88%
Crest Factor: 3 : 1

ENVIRONMENTAL

Ambient temperature range: +32 °F to +104°F (+0 °C to +40 °C)
Optimum temperature range: +59 °F to +77°F (+15 °C to +25 °C)
Storage temperature: -4 °F to +122°F (-20 °C to +50 °C)
Cooling: Forced air cooling
Humidity: 0-95%, non-condensing
Elevation: 10,000 feet max (operation), 45,000 feet (storage)
Audible noise: < 60 db normal and battery mode

STANDARDS

Safety: IEC / EN 62040-1-1
Emissions: IEC / EN 62040-2, CISPR 22
Immunity: EN 62040-2, CISPR 11
Conformity: CE
Transient Immunity: Per IEC 61000-4-5 level 3

MODEL & PART NUMBER DESIGNATION

UPS

230V Tower Models: VTWP-6000-02, VTWP-10000-02
 230V Rack-Tower Models (2U): VRTP-6000-02, VRTP-10000-02

EBP

Tower Models: VTPB-0007-240, VTPB-0009-240
 Rack-Tower Models: VRPB-0007-240, VRPB-0009240

230V Tower Models

Model Number	VTWP-6000-02	VTWP-10000-02
Capacity	6000VA 5400W	10000VA 9000W
Input Connection	6-Position Terminal Blocks, 57A, Bolt Size: M5	6-Position Terminal Blocks, 57A, Bolt Size: M5
Output Connection	6-Position Terminal Blocks, 57A, Bolt Size: M5	6-Position Terminal Blocks, 57A, Bolt Size: M5
Battery Type & Rating	Sealed, lead-acid 7Ah/12V	Sealed, lead-acid 9Ah/12V
Battery Quantity	20	20
Backup Time (full load)	8-10 min	7-9min
Recharge Time	<4 hours to 90 %	
Dimensions in / mm W x D x H	10.1 x 23.2 x 22.4 257 x 590 x 570	10.1 x 27.1 x 23 257 x 690 x 585
Weight lbs. / kg	190 / 86	212.7 / 96.5

230V 19" Rack-Tower Models

Model Number	VRTP-6000-02	VRTP-10000-02
Capacity	6000VA 5400W	10000VA 9000W
Input Connection	6-Position Terminal Blocks, 57A, Bolt Size: M5	6-Position Terminal Blocks, 57A, Bolt Size: M5
Output Connection	6-Position Terminal Blocks, 57A, Bolt Size: M5	6-Position Terminal Blocks, 57A, Bolt Size: M5
Battery Type & Rating	No Internal Batteries External Battery Pack (EBP) Required	
Battery Quantity		
Backup Time (full load)		
Recharge Time		
Dimensions in / mm W x D x H	UPS only 16.9 x 23.5 x 5.1 428 x 597 x 130	UPS only 16.9 x 25.9 x 5.1 428 x 657 x 130
Weight lbs. / kg	UPS only 44 / 20	UPS only 55 / 25

Tower Extended Battery Packs

Model Number	VTPB-0007-240	VTPB-0009-240
Capacity	6000VA 5400W	10000VA 9000W
Input Connection	Fixed Power Cord with color-coded Anderson connector	
Output Connection	Panel mounted, color-coded Anderson connector	
Battery Type & Rating	Sealed, lead-acid 7Ah/12V	Sealed, lead-acid 9Ah/12V
Battery Quantity	20	20
Backup Time (full load)	8-10 min	7-9 min
Recharge Time	<84 hours to 90 %	
Dimensions in / mm W x D x H	10.1 x 23.2 x 22.4 257 x 590 x 570	10.1 x 27.1 x 23 257 x 690 x 585
Weight lbs. / kg	190 / 86	212.7 / 96.5

19" Rack Mount Models

Model Number	VRPB-0007-240	VRPB-0009-240
Capacity	6000VA 5400W	10000VA 9000W
Input Connection	Fixed Power Cord with color-coded Anderson connector	
Output Connection	Panel mounted, color-coded Anderson connector	
Battery Type & Rating	Sealed, lead-acid 7Ah/12V	Sealed, lead-acid 9Ah/12V
Battery Quantity	20	20
Backup Time (full load)	10-15 min	9-10 min
Recharge Time	<84 hours to 90 %	
Dimensions in / mm W x D x H	16.9 x 23.5 x 5.1 428 x 597 x 130	16.9 x 25.9 x 5.1 428 x 657 x 130
Weight lbs. / kg	146 / 66	150 / 68



1. Limited Three-Year Warranty and Exclusions

NOTE: For this warranty to be valid, completed registration information must be received within 30 days of original purchase.

Marathon Power warrants to the original purchaser, who must have properly registered the product within 30 days of purchase, and not for the benefit of anyone else that this product at the time of its sale by Marathon Power is free of defects in materials and workmanship for three (3) years (batteries for 2 years within the USA, Canada and Mexico, otherwise 1 year) from the original purchase date. Marathon Power will correct such defects by repair or replacement, at its option, if within such three year period the product is returned prepaid and all warranty claim instructions are followed. This warranty excludes labor for removal or reinstallation of this product. This warranty is void if this product is installed improperly or in an improper environment, overloaded, misused, opened, abused, or altered in any manner, or is not used under normal operating conditions or not in accordance with all labels or instructions. There are no other or implied warranties of any kind, including merchantability and fitness for a particular purpose, but if any implied warranty is required by the applicable jurisdiction, the duration of any such implied warranty, including merchantability and fitness for a particular purpose, is limited to three years. Marathon Power is not liable for incidental, indirect, special or consequential damages, including damage to, or loss of use of, any equipment, lost sales or profits or delay or failure to perform this warranty obligation.

2. Limitations & Claims

This warranty does not cover any Marathon Power UPS or any properly connected electronic equipment which has been improperly installed, overloaded, abused or altered in any manner, or is not used under normal operating conditions, or in accordance with any labels or instructions, and does not cover any damage to properly connected electronic equipment resulting from a cause other than a "surge".

Damage caused by failure to provide a suitable installation environment for the product (including, but not limited to, lack of a good ground) will not be covered by this warranty. This warranty does not apply to damage caused by direct lightning strikes, or damage caused by electrical disturbances that exceed published product specifications. These products are intended to limit the maximum amplitude of transient voltage surges on power lines to specified values. They are not intended to function as surge arrestors. The UPS is intended to be installed on the load side of the service entrance and has been tested to verify that transient voltage surges are limited when subject to non-repetitive transient voltage surge events. This warranty excludes any incidental, indirect, special or consequential damages, including without limitation, labor for removal or reinstallation of the Marathon Power UPS or any connected electronic equipment, data loss or alteration loss of equipment use, lost sales or profits and any such damages for delay or failure to perform this warranty obligation. This warranty is in lieu of and excludes all implied warranties of merchantability or fitness for use. In addition, the warranty does not cover restoration of lost data and reinstallation of software. Some states may not allow the exclusion or limitation of incidental or consequential damages or other remedies, so the above exclusions or limitations may not apply to you.

Take the following steps to file a warranty claim: Contact us at Marathon Power, Inc., Attn: Returns, 2538 E. 54th Street, Huntington Park, California 90255 or call (310) 689-2328 within 30 days of the occurrence. Be prepared to provide detailed information about the event, any damage, the UPS model number, purchase date and location. You will then be provided with a Return Authorization Number (RAN), and be instructed to forward your proof of purchase (receipt), an explanation of the event and your UPS. If Marathon Power determines that the damage was due to a "surge", we may request that all connected equipment be submitted for evaluation. Marathon Power is not responsible for shipping costs. In the event that the equipment has been damaged by a "surge" Marathon Power will reimburse you for repair or replacement at fair market value (on a pro rata basis) as indicated by the respective amounts above. The warranty coverage is above and beyond, only to the extent needed, of that provided by any other source, including but not limited to any connected equipment coverage, any manufacturer's warranty or insurance policy. To receive payment for repair to damage due to a "surge," the original purchaser should (upon prior approval from Marathon Power) have such equipment repaired by an authorized service center of such equipment's manufacturer. The original purchaser will submit a repair bill along with a statement from the repair facility documenting the nature of the damage and how it was sustained to said equipment.



Marathon Power Inc., 2023

2538 E. 54th Street
Huntington Park, CA
Office: 310-689-2328
Fax: 310-689-2329
support@marathon-power.com
www.marathon-power.com