



Track Series

**Line Interactive, True Sine Wave Output
Uninterruptible Power Supply**

USER MANUAL

Introduction & Important Safety Instructions

Dear Customer,

Thank you for selecting a Marathon Power Uninterruptible Power Supply (UPS). You can rest assured that you have purchased a product consistent with our reputation for quality and reliability. It will provide you with years of protection against disruptive and costly power disturbances. As future needs arise, we hope you will consider other products of ours.

Sincerely,

Marathon Power Inc.

2538 E. 54th Street
Huntington Park, CA 90037
Tel: 310-689-2328
Fax: 310-689-2329

Please take the time to read this manual!

It provides safety, installation and operating instructions that will allow you to derive the maximum performance and service life from your UPS.

Please store this manual in a safe place!

It contains important instructions for the safe use of the UPS and for obtaining factory service should you experience operational difficulties.

Please save or recycle the packaging materials!

They were designed to provide adequate protection from transport related damage. Since damage sustained during transit is not covered under warranty, we recommend saving the material in case the UPS needs to be returned for service or repair. Alternately, please recycle them.

IMPORTANT SAFETY INSTRUCTIONS

SAVE THESE INSTRUCTIONS

1. This Manual Contains Important Instructions that should be followed during Installation and Maintenance of the UPS and Batteries.
2. The equipment can be operated by any individual. No previous experience is required.
3. **CAUTION (UPS with Internal Batteries):** Risk of electric shock - Hazardous live parts inside this unit are energized from the battery supply even when the input AC power is disconnected.
4. **CAUTION (No User Serviceable Parts):** Risk of electric shock, do not remove cover. No user serviceable parts inside. Refer servicing to qualified service personnel.
5. **CAUTION (Non-isolated Battery Supply):** Risk of electric shock, battery circuit is not isolated from AC input; hazardous voltage may exist between battery terminals and ground. Test before touching.
6. **WARNING (Fuses):** To reduce the risk of fire, replace only with the same type and rating of fuse.
7. **WARNING:** Intended for installation in a controlled environment. The maximum ambient temperature is 40°C.
8. **CAUTION:** When replacing batteries, replace with the same type and number of batteries:
9. **CAUTION:** Do not dispose of batteries in a fire, as they may explode.
10. **CAUTION:** Do not open or damage the battery, electrolyte may be released which is harmful to the skin and eyes.
11. **CAUTION:** A battery can present a risk of electric shock and high short circuit current. The following precautions should be taken when working with batteries:
 - a. Remove watches, rings and other jewelry or metal objects.
 - b. Use only tools with insulated handles.
 - c. Wear rubber gloves and boots.
 - d. Do not lay tools or metal parts on top of batteries.
 - e. Disconnect charging source prior to connecting or disconnecting battery terminals.
12. To reduce the risk of electric shock, disconnect the UPS from the AC input power supply before installing a communication interface cable. Reconnect the power cord only after communication interconnections have been made.
13. Battery replacement should be performed or supervised by personnel with knowledge of batteries. Keep unauthorized personnel away from the batteries.
14. **CAUTION:** To reduce risk of fire, use only No. 26 AWG or larger telecommunication line cord.
15. **CAUTION (For 700-2000VA Models Only):** To reduce risk of fire, connect only to a circuit provided with 20 amperes maximum branch circuit over-current protection in accordance with the National Electric Code, ANSI/NFPA 70". An AC output disconnect shall be provided by others.
16. **CAUTION (For 3000VA Models Only):** To reduce risk of fire, connect only to a circuit provided with 30 amperes maximum branch circuit over-current protection in accordance with the National Electric Code, ANSI/NFPA 70". An AC output disconnect shall be provided by others.
17. **CAUTION (For Models with I/P Terminal Block):** For 800 - 2000VA models: Use No. 10 AWG type TW cable, trade size 1 in. conduit, 60°C, copper wire for input and output field wiring. For 3000VA models: Use No. 8 AWG type TW cable, trade size 1 in. conduit, 60°C, copper wire for input and output field wiring. Use tightening torque of 40Nm to secure wiring to terminal block.

Table of Contents

Section	Page
1. Overview	1
2. Safety	1
3. Functionality	2
4. Installation	9
5. Operation	14
6. Alarms	15
7. Software Options	15
8. Care & Maintenance	16
9. Computer Interface Port	16
10. Battery Replacement	17
11. Storage	18
12. Fault Codes	18
13. Troubleshooting	19
14. Specifications	20
15. Product Warranties	24

1. Overview

Marathon Power's Track models are ideal for more critical applications where a true sine wave output while in backup mode is required along with the efficiency of a line-interactive design. Tap-changing AVR (Automatic Voltage Regulation) provides mitigation of sags and swells without the need to transfer to battery. Battery energy is conserved for more severe disturbances such as interruptions and outages.

Tight voltage and frequency regulation along with fast transfer ensures the seamless transfer of uninterrupted power to the load. Included is generic power monitoring & UPS control software. They feature a unique energy saving "Sleep Mode" that reduces the cost of ownership and "Cold Start" that allows the UPS to be used as a small emergency power source.

Using the UPS with the included software* and interconnecting cable allows intelligent control of the system when linked to a host computer. (Some operating systems require other optional software)

There are dry contacts or solid state signalling via a standard RS-232 port that allows for remote notification of basic functions such as Power Normal, Backup Mode, & Low Battery states.

* Software is presently available for PC operating systems only.

2. Safety



WARNINGS AND CAUTIONS!

Please be aware of, and observe the following:

- To reduce the risk of electric shock, disconnect the UPS from the main AC supply before installing any interface cables. Reconnect the power cord only after the signaling interconnections have been made.
- The internal energy source (the battery) cannot be de-energized by the user. The output may be energized when the unit is not connected to the AC supply.
- The correct way to de-energize the UPS properly in an emergency is to move the I/O switch to the OFF position and disconnect the power cord from the main supply.
- Even when the unit is disconnected, risk of electric shock from parts energized by the battery inside unit still exists. To avoid this, the battery supply should be disconnected at positive and negative terminals.
- The outlet sockets should be installed near the equipment and easily accessible.
- Do not dispose of batteries in a fire as they may explode. Please contact tech support for proper disposal instructions.
- Do not open or attempt to dismantle the battery, as electrolyte that is harmful to the skin and eyes may be released.
- A battery can present a risk of electric shock and high short circuit current. The following precautions should be taken when working with them:
 - Remove watches, rings and other jewelry or metal objects.
 - Use tools with insulated handles.
- To reduce risk of fire, replace only with same type and rating of fuse.
- To reduce the risk of fire or electric shock, install the UPS in a temperature and humidity controlled indoor area free of conductive contaminants.

3. Functionality - Front Views

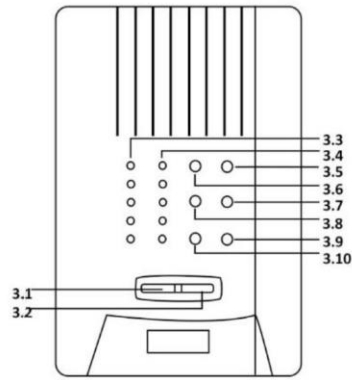

LED TOWER MODELS

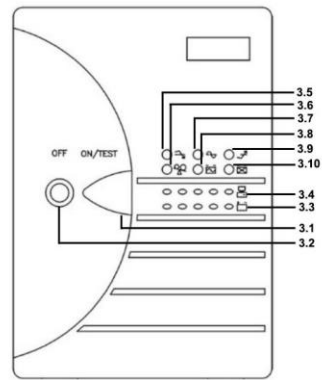

LED COMPACT TOWER MODELS

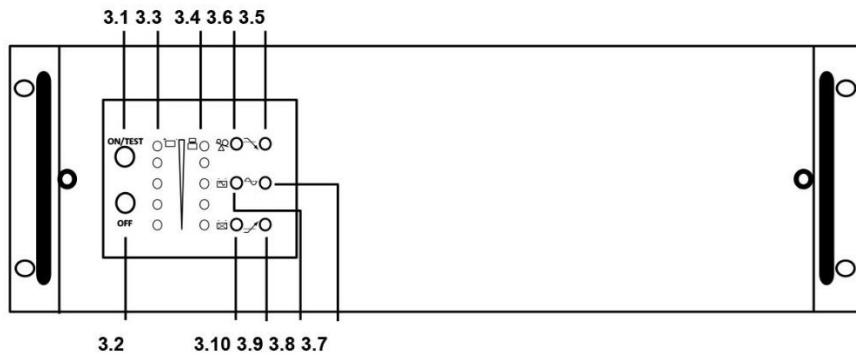

LED FRONT PANEL RACK MOUNT MODELS (3U & 4U)

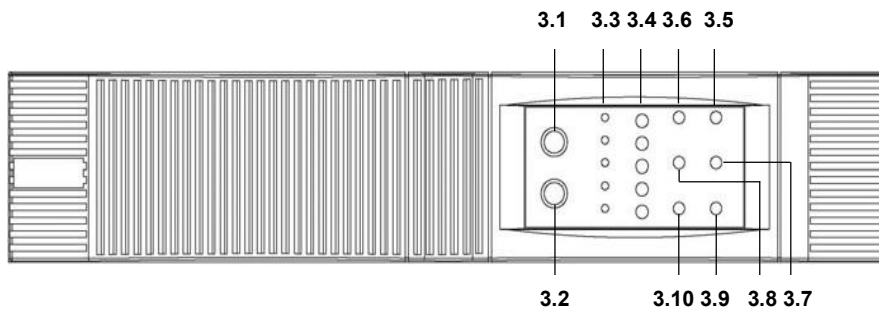

LED FRONT PANEL RACK MOUNT MODELS (2U)

3. Functionality - Front

FOR UNITS WITH AN LED DISPLAY

3.1 “ ON/TEST” Button

Once connected, pressing this button turns the UPS on and powers the loads. Depressing it for 1 (one) second activates the UPS's self-test function (while in normal power mode) or silences the alarm (while in backup mode).

3.2 “ OFF” Button

Pressing this button turns OFF the UPS and its connected loads.

3.3 “ POWER” Bar Graph (BATTERY CHARGE/LINE VOLTAGE)

This display shows the present battery charge as a percentage of battery capacity. It also displays utility line voltage.

3.4 “ LOAD” Bar Graph

This LED display shows the power being drawn by the load.

3.5 “ BUCK (AVR)” Indicator (YELLOW LED)

This LED illuminates when the UPS is correcting a voltage swell or over-voltage condition. The load receives normal power.

3.6 “ OVERLOAD” Indicator (RED LED)

This LED illuminates when the load(s) connected to the UPS exceeds the UPS's capacity (power rating). See Section 6.

3.7 “ LINE NORMAL” Indicator (GREEN LED)

This LED will illuminate when the AC line input voltage is normal.

3.8 “ BACKUP” Indicator (GREEN LED)

This LED illuminates when the UPS is supplying battery power to the loads.

3.9 “ BOOST (AVR)” Indicator (YELLOW LED)

This LED illuminates when the UPS is correcting a voltage sag or undervoltage condition. The load receives normal power.

3.10 “ REPLACE BATTERY” Indicator (RED LED)

This LED illuminates when the UPS's battery is no longer useful and must be replaced. See section 10.

3. Functionality - Front Views

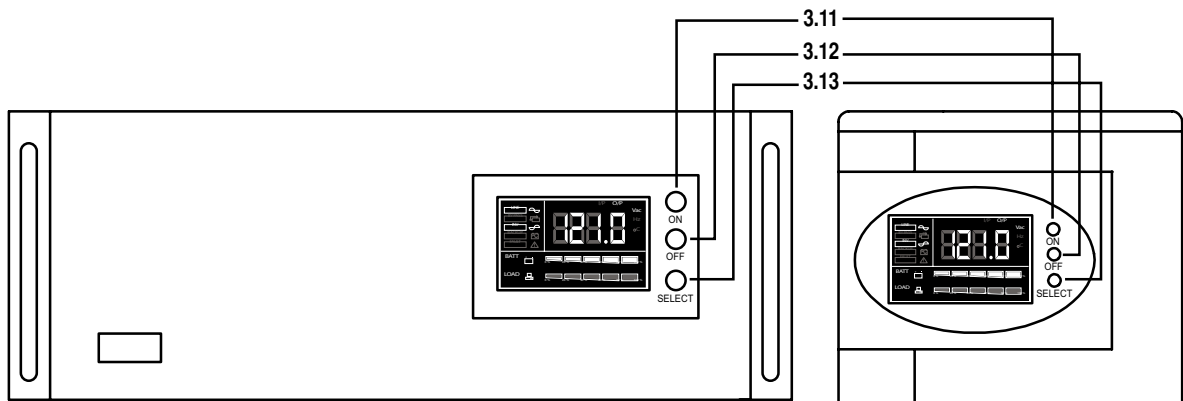

LCD RACK MOUNT MODELS (3U & 4U)

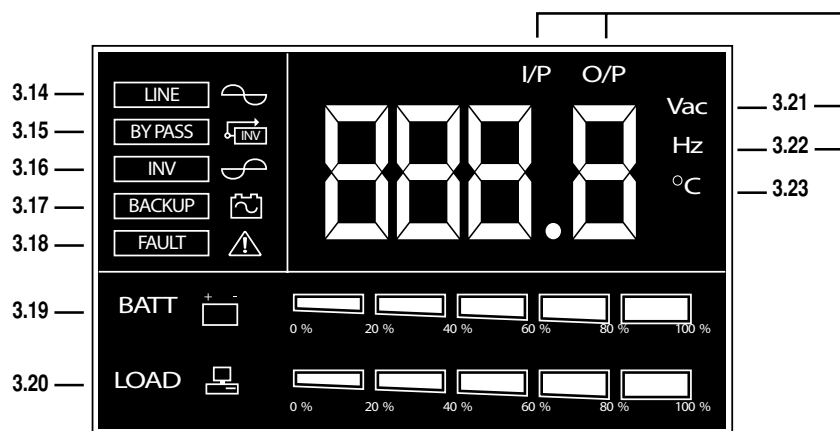

LCD DISPLAY DETAIL

LCD TOWER MODELS

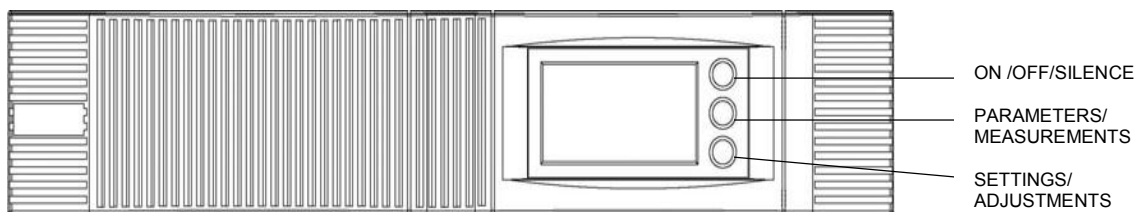

LCD FRONT PANEL (600~3000VA RM (2U))

3. Functionality - Front

FOR UNITS WITH AN LCD DISPLAY

3.11 “ ON/TEST” Button

Once connected, pressing this button turns the UPS on and powers the loads. It also activates the UPS's self-test and utility line voltage displays.

3.12 “ OFF” Button

Pressing this button turns OFF the UPS and its connected loads.

3.13 “ SELECT” Button

Depressing and holding the select button cycles through various LCD display modes. Modes include: Input Voltage, Output Voltage, Input Frequency, Output Frequency, Internal Temperature and Load (%).

3.14 LINE:

Indicates normal operation from AC line.

3.15 BYPASS:

Indicates the UPS is in bypass (standby) mode. Normal AC power supplies the load under this condition. When there is a power disturbance, the unit will transfer to backup mode.

3.16 INV:

This indicates that the inverter, and therefore the unit, is functioning properly. (The opposite of BYPASS mode.)

3.17 BACKUP:

Indicates unit is operating in backup mode during a power disturbance.

3.18 FAULT:

Indicates an internal electronic fault.

3.19 BATTERY LEVEL BAR GRAPH:

This graph shows the charge/energy level of the battery in 20% increments.

3.20 LOAD LEVEL BAR GRAPH:

This graph shows how much of the units available capacity is being utilized in 20% increments.

3.21 INPUT (I/P) OR OUTPUT (O/P) VOLTAGE (Vac):

Pressing the SELECT button until I/P and Vac are both lit will display the input voltage to the unit on the display. Likewise, you may press SELECT again to show O/P and Vac to indicate the units output voltage.

3.22 INPUT (I/P) OR OUTPUT (O/P) FREQUENCY (Hz):

Pressing the SELECT button until I/P and Hz are both lit will display the input frequency to the unit on the display. Likewise, you may press SELECT again to show O/P and Hz to indicate the units output frequency.

3.23 °C (Celsius):

With this indicator lit the unit will display the internal temperature of the unit in degrees celsius.

3. Functionality – Rear Views

(not to scale)

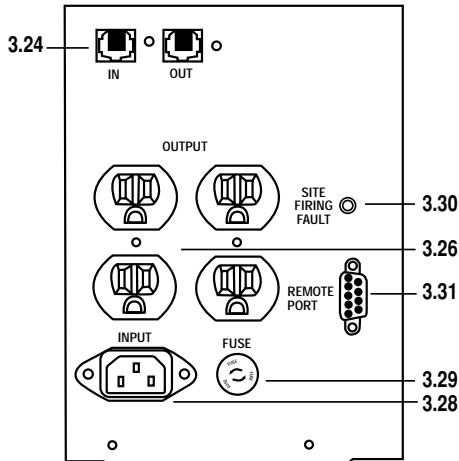

STANDARD 600VA / 1000VA TOWER MODELS

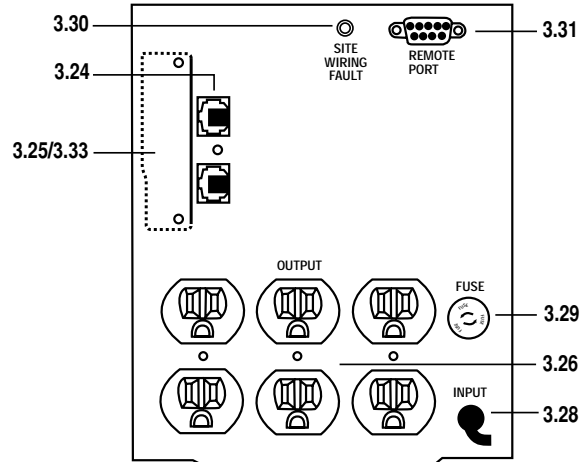

STANDARD 1500VA / 2000VA / 3000VA & EXTENDED RUN-TIME 1000VA TOWER MODELS

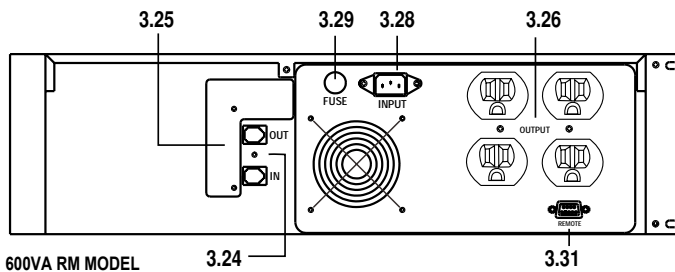

STANDARD 600VA RM MODEL

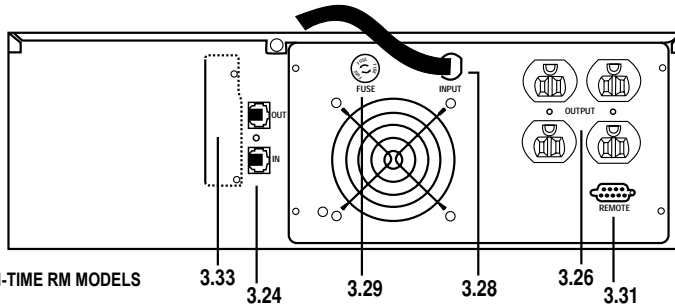

STD & EXT RUN-TIME RM MODELS

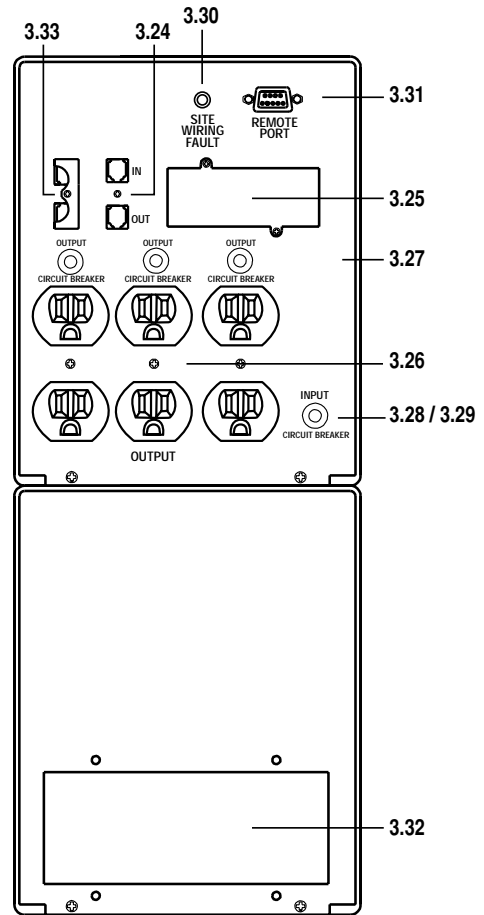

EXTENDED RUN-TIME 1500VA / 2000VA / 3000VA TOWER MODELS

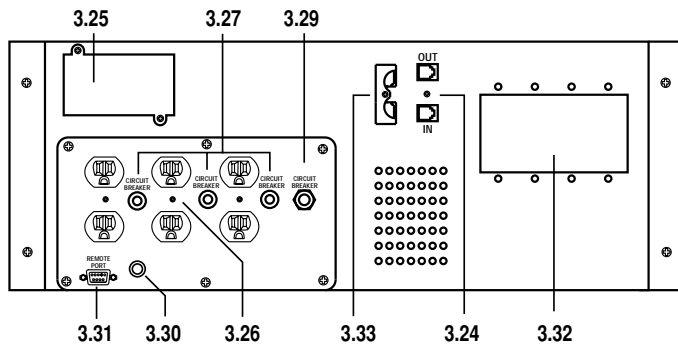

EXTENDED RUN-TIME RACK-MOUNT 3000VA MODEL

3. Functionality – Rear Views

REAR VIEW (LED COMPACT TOWER MODELS)

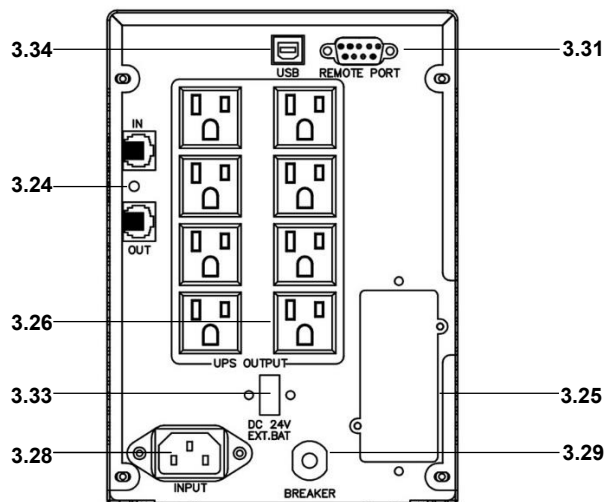

REAR VIEW (600~1000VA RM (2U))

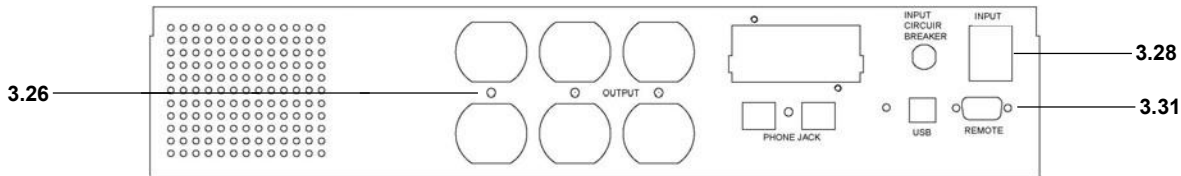

REAR VIEW (1500VA RM (2U))

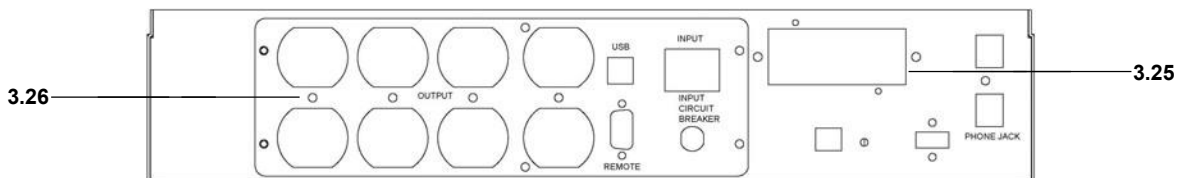

REAR VIEW (2000VA RM (2U))

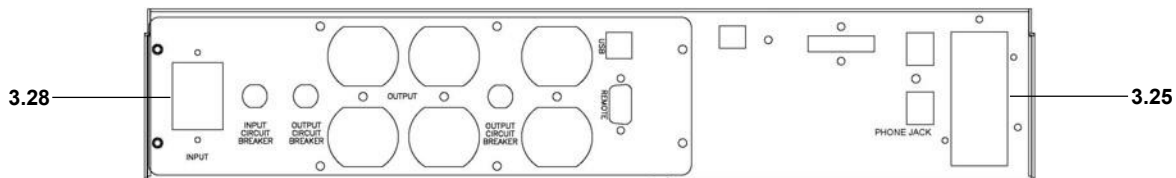

REAR VIEW (2500~3000VA RM (2U))

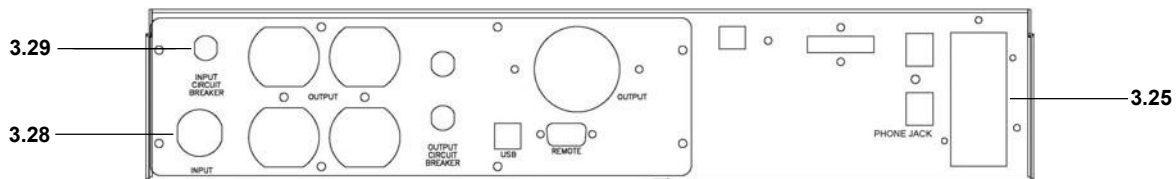

3. Functionality – Rear

3.24 TELEPHONE / MODEM SURGE PROTECTION Sockets

Surge protection for telephone and modem lines.

3.25 SNMP INTERFACE (optional) Port Cover

Provides access to the optional SNMP adapters for Ethernet and Token Ring connectors. The SNMP adapter makes the UPS “SNMP manageable”, providing real time UPS and system status information for a network manager.



NOTE: For more information on obtaining an SNMP adapter, contact Marathon Power technical support.

3.26 AC OUTPUT POWER RECEPTACLES

3.27 OUTPUT CIRCUIT BREAKERS

The circuit breaker will trip if one or both of the protected outlets are short circuited. (or see a short circuit)



NOTE: Each fuse protects the outlet pair either directly to the left, or below itself.

3.28 AC INPUT POWER RECEPTACLE / CABLE

3.29 INPUT FUSE OR CIRCUIT BREAKER

The fuse will blow, OR circuit breaker will trip when the connected loads exceed the protected receptacle's capacity.



CAUTION: Replace only with same fuse type and rating.

3.30 SITE WIRING FAULT INDICATORS (RED LED) (Some Models)

This LED illuminates when the UPS is connected to an improperly wired AC power outlet.



NOTE: Available on 120V models only.

3.31 COMPUTER INTERFACE / REMOTE SIGNALLING

Provides both RS-232 and dry contact relay signals to support various operating systems.

NOTE: Use only a factory supplied or authorized connecting cable for this.

3.32 HARDWARE INPUT/OUTPUT TERMINAL BLOCK (3000VA Models)

The terminal block is used to “hardwire” the UPS, thus allowing connection of input/output wiring. Use #8 AWG wire (Twisted wire cable) for possible 1” conduit use and terminate each wire with appropriate size/rating terminal lugs. Input/Output wires should be secured with terminal block screws using 29 ft.-lbs. of torque.

3.33 EXTERNAL BATTERY PACK CONNECTOR (Extended Run-Time Models)

For the connection of additional batteries for extended run-times.



NOTE: Use only a factory supplied or authorized connecting cable for this. Installation information can be found in the user manual supplied with the battery pack.

3.34 USB PORT

Provides an interface between the UPS and a host computer for monitoring and control of the UPS and computer via the UPSMON software.



NOTE: Use only a factory supplied or authorized connecting cable for this.

4. Installation

4.1 Inspection

Inspect the UPS upon receipt for any visible damage. The packaging is recyclable; save it for reuse or dispose of it properly.



NOTE: If the power consumption of the load is listed in units other than VA (e.g., Watts), use the following calculations for conversion:

$$\text{_____ Watts(W)} \times 1.67 = \text{_____ VA} \quad \text{OR} \quad 120\text{V} \times \text{_____ Amps(A)} = \text{_____ VA}$$

4.2 Placement

Install the UPS in a protected area with adequate airflow and free of excessive dust.



CAUTION: Do NOT operate the UPS where the temperature and humidity is outside the specified limits.

4.3 Telephone / Modem Line Connection

Connect a single line telephone or a modem line to the telephone/modem surge protection sockets on the rear of the UPS. The RJ-45 modular sockets accept standard single line telephone connectors. This connection requires an additional length of telephone cable (supplied).

CAUTION: The telephone/modem line connection is optional and not necessary for the UPS to function correctly.



NOTE: The telephone line current limiting feature may be rendered inoperable if improperly installed. Make sure that the telephone line from the wall is plugged into the connector labeled "IN", and the device to be protected (telephone, modem, etc.) is plugged into the connector labeled "OUT".



NOTE: This surge protection device is for indoor use only. Never install telephone wiring during a lightning storm.

4.4 Power Source Connection

4.41 Cord connected models

Connect the AC power cord to a properly wired and grounded outlet to energize the UPS

4.42 Hardwired models

The terminal block is used to "hardwire" the UPS, thus allowing connection of input/output wiring. Use #8 AWG wire (Twisted wire cable) for possible 3/4" conduit use and terminate each wire with appropriate size/rating terminal lugs. Input/Output wires should be secured with terminal block screws using 29 ft.-lbs. of torque.

4.5 Battery Charging

The UPS charges its battery whenever it is connected to utility power. For optimum results, charge the battery for at least 6 hours prior to initial use.

4.6 Load Connection

Plug the load(s) into the output receptacles or connect them to the hard-wired terminal block on the rear of the UPS. To use the UPS as a master ON/OFF switch, make sure all of the loads are switched ON.



CAUTION: Do NOT connect a laser printer or plotter to the UPS with other computer equipment. A laser printer or plotter periodically draws significantly more power than when idle, and may overload the UPS. (Does not apply to some models which may be oversized to accommodate such).

4.7 Site Wiring Fault Indicator Inspection (where applicable)

After connecting the loads and the UPS, check the site wiring fault indicator on the rear panel. See section 3 for location of the indicator on the rear panel. It will illuminate if the UPS is connected to an improperly wired AC power outlet. Wiring faults detected include ground, hot-neutral polarity reversal, and overloaded neutral circuit.

4.8 Computer Interface Connection (optional)

Power monitoring software and interface kits are included with each UPS. If used, ensure that all equipment is OFF and connect one end of the interface cable to the 9-pin computer interface port on the back panel of the UPS and the other end to an unused COM port on the computer. Use only kits and/or cables supplied or approved by the manufacturer. See section 7 for additional info.



NOTE: The computer interface connection is optional and not necessary for the UPS to function correctly.

4.9 External Battery Pack Connection (Extended Run-Time Models)

Before connecting, ensure that the external battery pack and connector cable are compatible with the UPS. Use only the factory supplied, external battery connection cable.



NOTE: The external battery connection is optional and not necessary for the UPS to function correctly.

4.10 Rack Mount Models

Depending on installation, 19" rack-mount applications may require the use of guide rails and/or brackets to support the weight of the UPS. Please contact the manufacturer of your rack or enclosure to purchase suitable mounting/installation hardware.

A Note on RFI (Radio Frequency Interference)

There is no guarantee that interference to a radio or TV receiver will not occur in a particular installation. If the UPS causes interference to radio or television reception, which can be determined by turning the UPS OFF and ON, the user is encouraged to try to rectify the problem by trying one or more of following:

- Connect the equipment to an outlet on a circuit different from that to which the receiver is connected.
- Increase the separation between the equipment and the receiver.
- Re-orient the receiving antenna.

Vertical and Wall-Mount Installation

The following diagrams illustrate how to install or mount the UPS (and battery packs when applicable) in either vertical or wall-mount applications:

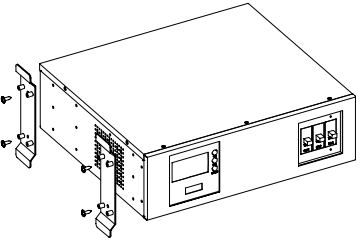
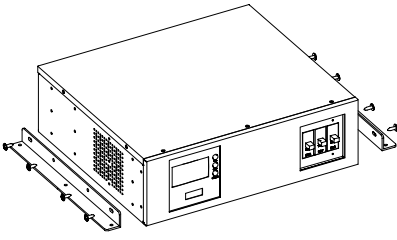
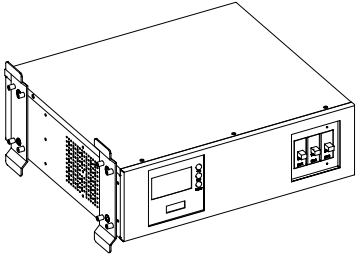
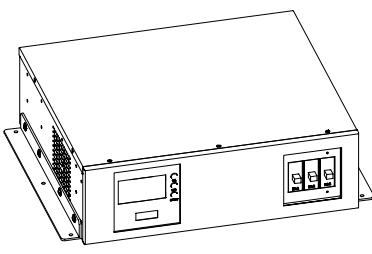
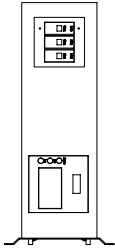
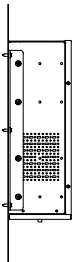
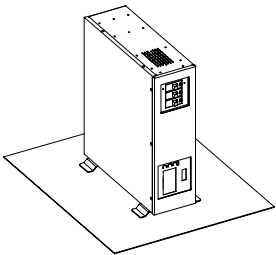
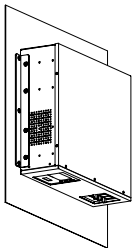
Vertical Installation	Wall-mount Installation
	
	
	
	

19" Rack-Mount Installation

The following diagrams illustrate how to install or mount the UPS (and battery packs when applicable) in 19" rack-mount applications:

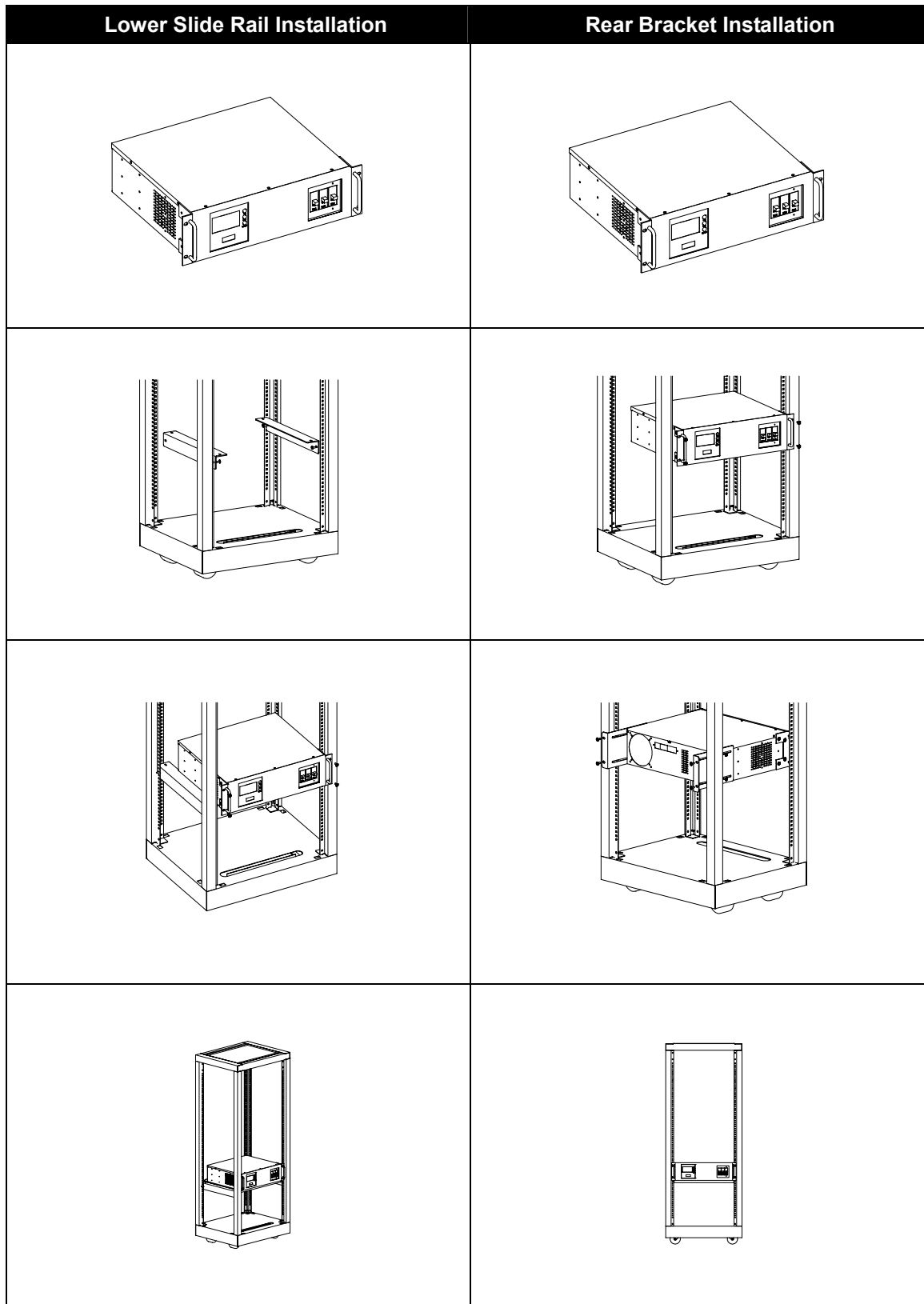

Unit Stack Installation

The following diagrams illustrate how to stack the units (and battery packs when applicable):

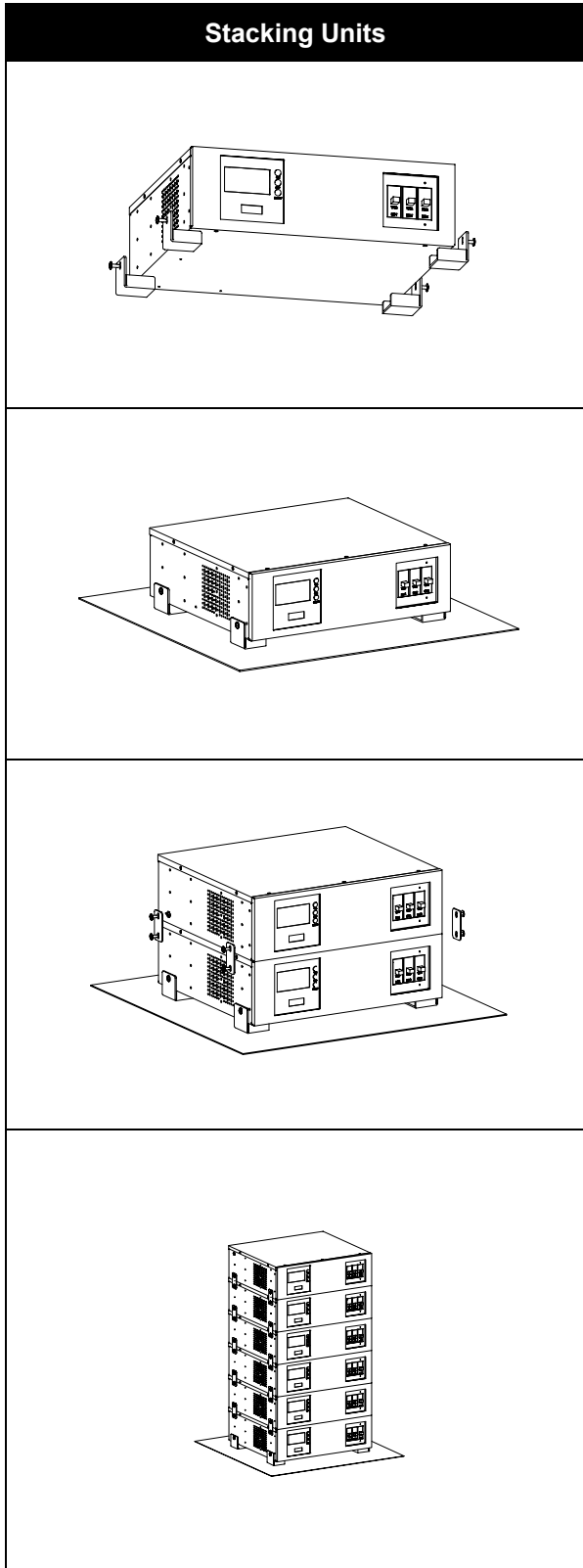

5. Operation

5.1 Turn-ON

With the UPS plugged in, press the ON/TEST button more than 2 seconds to energize the UPS. It will perform a self-test each time it is switched ON.



NOTE: When switched OFF, the UPS will maintain and continue to charge the battery and also respond to commands received through the computer interface port.

5.2 Turn-OFF

Press and hold the OFF button until the “LINE NORMAL” or “BACKUP” LED turns OFF.

5.3 Self-Test

Use the self-test to verify both the operation of the UPS and the condition of the battery. To perform the self-test, press the ON/TEST button more for more than 1 second, but less than 2 seconds, under normal power conditions. During the self-test, the UPS will operate in back-up mode.



NOTE: During the self-test, the load(s) use battery energy. The “ON BATTERY” LED or BACKUP LCD icon will illuminate indicating the UPS is supplying power.

If the UPS passes the self-test, it will return to normal on-line operation. The “ON BATTERY” LED or BACKUP LCD icon will turn OFF and the “ON LINE” LED or INV LCD icon will illuminate.

If the UPS fails the self-test, it immediately returns to on-line operation and the “REPLACE BATTERY” LED or LCD error code will illuminate, however the loads are not affected. Recharge the battery overnight and perform the self-test again. If the “REPLACE BATTERY” LED or LCD error code is still illuminated, call tech support for battery replacement instructions.

5.4 Audible Alarm Silencing

To silence the audible alarm, press the “ON/TEST” button for less than one second while the UPS is in back-up mode.



NOTE: This function will not work when the UPS is under “Low Battery” or “Overload” conditions.



NOTE: In back-up mode, the UPS will automatically turn OFF if none of the connected loads are active.

5.5 Load Bar Graph

The 5 LED or LCD segment display indicates the power drawn from the UPS by the load. The number of illuminated LEDs or segments represents the percentage of the UPS's rated capacity being utilized. For example, if two LEDs or segments are illuminated, the load is drawing between 20% and 40% of the UPS's rated capacity. (See section 3 for location of the display on the front panel)

If the UPS is overloaded, the “OVERLOAD” LED or LCD error code illuminates and an alarm sounds.

5.6 Battery Charge Bar Graph

The 5 LED or LCD segment display shows the present charge of the UPS's battery as a percentage of the battery capacity. When all 5 LEDs or segments are illuminated, the battery is fully charged.

(see section 3 for location of the display on the front panel).

5.7 Cold Start

When the UPS is OFF and there is no utility power available or present, the cold start feature can be used to apply power to the loads from the UPS using the battery as the power source. Press the ON/TEST button until the UPS beeps and powers up.

5.8 Shutdown Mode

In this mode, the UPS ceases supplying power to the load after battery depletion while waiting for the return of utility power. If utility power is not restored, an external device, such as a server with the included software connected to the UPS via the RS-232 interface, can command the UPS to shut down. This is typically done to preserve battery capacity after the proper shutdown of protected loads.

6. Alarms

6.1 “ BACKUP” (slow alarm)

When in back-up mode, the UPS sounds an audible alarm. The alarm stops when the UPS returns to LINE NORMAL operation. It can be silenced by briefly pressing the “ON/TEST” button when in backup mode.

6.2 “ LOW BATTERY” (rapid alarm)

In back-up mode, when the battery level runs low, the UPS beeps rapidly until either the UPS shuts down due to battery depletion or it returns to LINE NORMAL operation.



NOTE: The alarm can not be silenced under this condition.

6.3 “ OVERLOAD” (continuous alarm)

When the UPS is overloaded (i.e., the connected load(s) exceed the maximum rated capacity) the UPS emits a continuous tone to warn of an overload condition. Disconnect non-critical loads from the UPS to eliminate the overload.

6.4 “ REPLACE BATTERY” (continuous alarm) (Some Models)

The UPS emits a continuous tone if the battery fails the self-test. See section 10 for instruction on user battery replacement or contact tech support for assistance.

7. Software Options

7.1 Power Monitoring Software



NOTE: Please refer to the back of the software CD envelope for installation instructions. For operational instructions, install the software, launch the program then click HELP in the upper left corner of the software application screen.

The software is applied via the standard RS-232 interface to perform monitoring functions, as well as to implement an orderly shutdown of a computer in the event of a continuous power failure. In addition, it displays diagnostic features, such as: input and output voltage, frequency, battery and load level visually on your computer monitor.

The software is usable with DOS, Windows 3.1x or higher, Windows NT V3.5 or later, and others. Contact tech support for more information on alternative computer OS compatible software.

7.2 Interface Kits

Included interface kit provides UPS monitoring. Each kit includes a special cable to convert status signals from the UPS into signals which individual operating systems recognize. One end of the cable is connected to the remote port on the UPS and the other end to either the COM 1 or COM 2 port on the computer. An SNMP/WEB network card or module is also available for most models.



NOTE: Use only a factory supplied or authorized monitoring cable.

8. Care & Maintenance

1. Keep the unit clean and vacuum the ventilation intake periodically.
2. Wipe with a soft, damp cloth.
3. Check for loose and/or bad connections monthly.
4. Never leave the unit on an uneven surface.
5. Position the unit to allow at least 1/2" (1.3 cm) clearance between the rear panel and the wall.
6. Keep the ventilation intake(s) open.
7. Avoid direct sunlight, rain, and high humidity.
8. Keep away from fire and extremely hot locations.
9. Do not stack anything on top of the unit.
10. The unit should not be exposed to corrosive environments.
11. Normal operating temperature is 32 to 104°F (0-40°C).

9. Computer Interface Port

1. The communication port on the back of the UPS may be connected to the host computer. The port allows the computer to monitor the status of the UPS and, in some cases, control the operation of the UPS.
2. Major functions include some or all of the following:
 - Power disturbance notification.
 - Closure of any open files prior to battery depletion.
 - UPS power-up or OFF.
3. Although most computers are equipped with a connector (via COM port) to allow a link to the communication port on the back of the UPS, a special plug-in card may be needed in the event one is not available. Some computers may also need special software. Contact tech support for details on various interface kits.
4. The computer interface port has the following characteristics:
 - Pin 6 and 8 are open collector outputs which must be pulled up to a common reference supply of no greater than +40 VDC.
 - The transistors are capable of a maximum nonconductive load of 25 mA DC. Use pin 5 only as the common.
 - Pin 8 generates a High to Low signal when the battery inside the UPS is low.
 - Pin 6 generates a High to Low signal when the line fails.
 - The UPS will shut down when a high RS-232 level is sustained on pin 3 for 0.5 seconds.
 - Pin 9 is also used for RS-232 data output.
 - Pin 3 is used for the RS-232 data input.

NOTES:

- Switch rating +40V, 0.15A non-inductive.
- Pin 5 should be connected to ground only.

Pin#	I/O	Function Explanation
6	OUT	Power failure, normally open, will become closed upon activation
5	OUT	Reference for pins 6 & 8 (ground)
8	OUT	Battery Low, normally open, will become closed upon activation
3	IN	Remote shutdown UPS - Applying voltage (+5V ~ +12V) to this pin for 500ms shuts the UPS down.
4/7	OUT	+12V / -12V

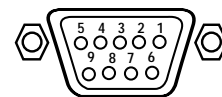

10. Battery Replacement

 NOTE: Under normal operation, the battery's life span will be 3-5 years before requiring replacement.

CAUTIONS:

1. When replacing batteries, replace with the same type and number of batteries.
2. Do not dispose of batteries in a fire, as they may explode.
3. Do not open or damage the battery, electrolyte may be released which is harmful to the skin and eyes. A battery can present a risk of electric shock and high short circuit current. The following precautions should be taken when working with batteries:
 - a. Remove watches, rings and other jewelry or metal objects.
 - b. Use only tools with insulated handles.
 - c. Wear rubber gloves and boots.
 - d. Do not lay tools or metal parts on top of batteries.
 - e. Disconnect charging source prior to connecting or disconnecting battery terminals.

Marathon Power strongly recommends that you contact tech support for assistance with battery replacement.

To change the batteries in Tower units:

1. Unplug the UPS unit from the AC power source and disconnect all connected equipment.
2. Disconnect the AC power cord from the UPS.
3. Remove the two (2) front panel securing screws located on either side of the unit.

 NOTE: Some models; Remove the two (2) lower front panel screws located on both sides of the unit.

4. With the appropriate fingers placed in the recesses on either side, gently pull the front panel forward until it disengages. Do NOT pull it too far forward as there is a wire harness connected to it from the inside of the unit.

 NOTE: This step does not apply to some models.

5. Rotate the front panel to the left so that it is out of the way.

 NOTE: Some models; Lift the front of the unit, and gently push down on the front door to unhinge .

6. The interconnecting wires and electronics will be exposed. Be careful not to touch any inner components when changing the battery.
7. Remove the securing screws and then the battery cover plate.
8. The battery can now be removed from the unit. Slide the battery out, disconnect and discard appropriately.
9. Place the new battery in the same position / direction as before and reconnect the wires. Connect the RED wire to Positive (+) and the BLACK wire to Negative (-).
10. Follow the reverse of steps above to re-assemble the UPS.
11. Follow user manual instructions to correctly reconnect the UPS loads.

To change the batteries in 19" Rack Mount units:

1. Unplug the UPS unit from the AC power source and disconnect all connected equipment.
2. Disconnect the AC power cord from the UPS.
3. Remove the two (2) front panel securing screws located on the front of the unit.
4. The interconnecting wires and electronics will be exposed. Be careful not to touch any inner components when changing the battery.



NOTE: This step does not apply to some models.

5. Remove the five (5) securing screws and then the battery cover plate.



NOTE: Some models; Remove the four (4) securing screws.

6. The battery(s) can now be removed from the unit. Slide the battery out, disconnect and discard appropriately.
7. Place the new battery in the same position / direction as before and reconnect the wires. Connect the RED wire to Positive (+) and the BLACK wire to Negative (-).
8. Follow the reverse of steps above to re-assemble the UPS.
9. Follow user manual instructions to correctly reconnect the UPS loads.



NOTE: For proper battery disposal & recycling information, please call 800-RE-USE-Pb. (800-738-7372)

11. Storage

11.1 Storage Conditions

Store the UPS covered, upright and in a cool, dry location, with its battery fully charged. Before storing, charge the UPS for at least 8 hours. Remove any accessories from the unit and disconnect any cables connected to the computer interface port to avoid draining the battery.

11.2 Extended Storage

During extended storage in environments where the ambient temperature is +5 to +86°F (-15 to +30°C), charge the UPS's battery every 6 months. During extended storage in environments where the ambient temperature is +86 to +113°F (+30 to +45°C), charge the UPS's battery every 3 months.

12. Fault Codes (LCD Models)

Displays Fault Code: E01	Output failure Internal fault	Do not attempt to use UPS. Turn it off and have it serviced
Displays Fault Code: E02	Over-temperature High ambient temp or internal fault	Power unit off and allow to cool down. Once cool, power up and if problem persists, contact technical support
Displays Fault Code: E03	Output short circuit Fault with connected equipment or internal malfunction	Remove connected loads one-by-one to indentify. If fault persists, contact technical support
Displays Fault Code: E04	Overload Condition Rating/s of connected equipment exceeds capacity of unit	Reduce load by removing some of the tconnected equipment fro the unit
Displays Fault Code: E05	Battery DC Bus Problem Positive/Negative connections incorrect or DC bus voltage incorrect	Remove AC power from the unit and reverse battery connections if incorrect RED = + BLACK = —
Displays Fault Code: E06	Incorrect Charger Voltage Faulty battery charger	Contact technical support
Displays Fault Code: E07	Battery Fault Battery(ies) faulty or at the end of their useful life	Replace battery(ies)

13. Troubleshooting

<i>Problem</i>	<i>Possible Cause</i>	<i>Corrective Action</i>
Unit will not turn ON	ON/TEST button not pushed or not pushed long enough.	Press the ON/TEST button for more than 2 seconds to power the UPS and load.
	Fuse is blown or the circuit breaker has tripped.	Remove connected loads from the UPS by unplugging equipment and reset the circuit breaker.
	Output short circuit, or UPS is overloaded.	To remove short circuited equipment or overload, disconnect connected equipment then re-set the circuit breaker.
	Very low or no utility voltage.	Check the AC power supply to the UPS.
UPS will not turn ON or OFF	Computer interface or accessory problem. ON/TEST or OFF button not pushed long enough.	Disconnect the computer interface or accessory. If the UPS then functions normally, check the interface cable, the attached computer and/or the accessory.
UPS operates on battery even though line voltage is apparently present	UPS's input circuit breaker tripped, or input fuse is blown.	Remove connected loads from the UPS by unplugging equipment and reset the circuit breaker.
UPS beeps slowly	Normal UPS operation.	None – the UPS is supporting the load.
UPS does not provide expected back-up time	The UPS's battery is not fully recharged due to recent use or it is near the end of its service life.	Charge the battery. If the battery is near the end of its service life, consider replacing it, even if the fault code "E07" has not been displayed yet.
	The UPS is overloaded.	Check the UPS's load display and remove noncritical loads.
Front panel indicators flash sequentially (LED models)	The UPS has shut down by remote control.	None - The UPS will restart automatically when the utility power returns if configured to do so, or manually turned on.
All indicators are flashing and UPS emits a constant tone	Internal UPS fault.	Do not attempt to use the UPS. Turn it off, power it down and have it serviced.
UPS operates normally, but the site wiring fault indicator is on.	Building wire error - e.g. missing Ground or Hot and Neutral wires are reversed.	Have a qualified electrician correct the building wiring.
Low battery light is ON and all LED's are OFF	The UPS has shut down and the battery has been discharged or depleted.	None - The UPS will return to normal operation when the utility power is restored and the battery is sufficiently recharged.
Replace battery light is ON	Faulty batteries.	The batteries may need to be recharged for at least 4 hours. Should the problem persist - replace with new batteries.

14. Specifications

STANDARD RUN-TIME MODELS

GENERAL

Rated Capacity: 600VA, 1000 VA, 1500 VA, 2000 VA, 3000 VA with a power factor of 0.6
Technology: Line-interactive topology with true sinewave output on battery

INPUT

Phase: Single phase plus ground
Input Voltages: 110V, 115V, 120V or 220V, 230V, 240V
Input Voltage Range: $\pm 25\%$
Frequency: 50 / 60 Hz auto sensing
AC Frequency Range: 45 - 65 Hz
Input Current (120V): 600VA - 5A, 1000VA - 8.2A, 1500VA - 12.4A, 2000VA - 16.5A, 3000VA - 25A
Input Current (230V): 600VA - 2.6A, 1000VA - 4.4A, 1500VA - 6.5A, 2000VA - 8.7A, 3000VA - 13A
Input Protection: Fuse or circuit breaker for overload and short circuit (model dependent)
DC Bus Voltage: 600VA - 24V, 1000VA - 24V, 1500VA - 36V, 2000VA - 48V, 3000VA - 96V

OUTPUT

Output Voltage: 110V, 115V, 120V or 220V, 230V, 240V
Voltage Regulation: $\pm 5\%$ (600VA - 3000VA)
Voltage Distortion: $< 5\%$ THD with non-linear loads, $< 3\%$ THD with linear loads
Frequency Regulation: $\pm 0.5\%$ (while on battery)
Automatic Voltage Regulation: Increases or decreases output voltage by 15% if the input voltage decreases or increases by between 9% and 25%
Transfer Time: Between 4 and 8 milliseconds including detection time
Efficiency (Standby Mode): Greater than 95%
Overload Capacity: 110% for 20 seconds, 125% for 5 seconds

EXTENDED RUN-TIME MODELS

GENERAL

Rated power: 1000 VA, 1500 VA, 2000 VA, 3000 VA with a power factor of 0.6
Technology: Line-interactive topology with true sinewave output on battery

INPUT

Phase: Single phase plus ground
Input Voltages: 110V, 115V, 120V or 220V, 230V, 240V
Input Voltage Range: $\pm 25\%$
Frequency: 50 / 60 Hz auto-sensing
AC Frequency Range: 45 - 65 Hz
Input Current (120V): 1000VA - 8.2A, 1500VA - 12.4A, 2000VA - 16.5A, 3000VA - 25A
Input Current (230V): 1000VA - 4.4A, 1500VA - 6.5A, 2000VA - 8.7A, 3000VA - 13A
Input Protection: Fuse or circuit breaker for overload and short circuit (model dependent)
DC Bus Voltage: 1000VA - 24V, 1500VA - 36V, 2000VA - 48V, 3000VA - 48V

OUTPUT

Output Voltage: 110V, 115V, 120V or 220V, 230V, 240V
Voltage Regulation: $\pm 5\%$ (1000VA - 3000VA)
Voltage Distortion: $< 5\%$ THD with non-linear loads, $< 3\%$ THD with linear loads
Frequency Regulation: $\pm 0.5\%$ (while on battery)
Automatic Voltage Regulation: Increases or decreases output voltage by 15% if the input voltage decreases or increases by between 9% and 25%
Transfer Time: Between 4 and 8 milliseconds including detection time
Efficiency (Standby Mode): Greater than 95%
Overload Capacity: 110% for 20 seconds, 125% for 5 seconds

14. Specifications

ALARMS AND INDICATORS

Battery Backup:	Slow beeping tone (approx. 0.25Hz)
Battery Low:	Rapid beeping tone (approx. 1.00Hz)
Overload:	Continuous tone
Front Panel Display:	LED on standard runtime models & LED or LCD on extended runtime models
Display Parameters (LED):	On Line (AC normal), On Battery (AC failure), AVR Boost, AVR Buck, Battery Capacity/Level (%), Load Level (%), Overload
Display Parameters (LCD):	Input voltage, Output voltage, Input Frequency, Output Frequency, Load (%), Internal Temperature (°C)
Communication (std): (optional):	RS-232 bi-directional communication port and solid state signaling SNMP/WEB card or module for monitoring and control on network or internet

STANDARDS

Safety:	EN50091-1-1
Emissions:	EN50091-2 class B
Immunity:	EN50091-2
Conformity:	UL 1778, cUL 107.1, 107.2, (120V models), CE (230V Models)
Transient Immunity (120V):	Per IEEE 62.41 (formerly IEEE 587)
Transient Immunity (230V):	Per IEEE C 61000-4-5 level 3

ENVIRONMENTAL

Ambient temperature range:	+32 °F to +95°F (+0 °C to +35 °C) (1000 ~ 2000VA extended run-time models) +32 °F to +104°F (+0 °C to +40 °C) (All standard run-time models) +32 °F to +77°F (+0 °C to +25 °C) (3000VA extended run-time models)
Optimum temperature range:	+59 °F to +77°F (+15 °C to +25 °C)
Storage temperature:	+5 °F to +122°F (-15 °C to +50 °C)
Cooling:	Forced air cooling
Humidity:	0-95%, non-condensing
Elevation:	10,000 feet max (operation), 45,000 feet (storage)
Audible noise:	< 40 db normal and battery mode (600-1000 VA models) < 45 db normal and battery mode (1500-3000 VA models)

MODEL & PART NUMBER DESIGNATION - Standard Run-Time Models

120V Tower Models:	TTWS-0600-01, TTWS-1000-01, TTWS-1500-01, TTWS-2000-01, TTWS-3000-01
230V Tower Models:	TTWS-0600-02, TTWS-1000-02, TTWS-1500-02, TTWS-2000-02, TTWS-3000-02
120V Compact Tower Models:	TTWC-1000-01, TTWC-1250-01, TTWC-1500-01, TTWC-2000-01, TTWC-3000-01
230V Compact Tower Models:	TTWC-1000-02, TTWC-1250-02, TTWC-1500-02, TTWC-2000-02, TTWC-3000-02
120V Rack-Mount Models (3U):	TRMS-0600-01, TRMS-1000-01, TRMS-1500-01, TRMS-2000-01
230V Rack-Mount Models (3U):	TRMS-0600-02, TRMS-1000-02, TRMS-1500-02, TRMS-2000-02
120 V Rack-Mount Models (2U):	TRMU-0600-01, TRMU-1000-01, TRMU-1500-01, TRMU-2000-01, TRMU-3000-01
230V Rack-Mount Models (2U):	TRMU-0600-02, TRMU-1000-02, TRMU-1500-02, TRMU-2000-02, TRMU-3000-02

MODEL & PART NUMBER DESIGNATION - Extended Run-Time Models

120V Tower Models:	TTWE-1000-01, TTWE-1500-01, TTWE-2000-01, TTWE-3000-01
230V Tower Models:	TTWE-1000-02, TTWE-1500-02, TTWE-2000-02, TTWE-3000-02
120V Rack-Mount Models:	TRME-1000-01, TRME-1500-01, TRME-2000-01, TRME-3000-01
230V Rack-Mount Models:	TRME-1000-02, TRME-1500-02, TRME-2000-02, TRME-3000-02

14. Specifications (cont'd)

Standard Run-Time Tower Models

Capacity	600VA / 360 W	1000VA / 600 W	1500VA / 900 W	2000VA / 1200 W	3000VA / 1800 W
Input Connection	Fixed power cord				Hardwire terminals
Output Connection	4 x NEMA 5-15R		6 x NEMA 5-15R		H/W + 4 x NEMA
Battery Type & Rating	Sealed, lead-acid 7.2Ah/12V	Sealed, lead-acid 7.2Ah/12V	Sealed, lead-acid 7.2Ah/12V	Sealed, lead-acid 7.2Ah/12V	Sealed, lead-acid 7.2Ah/12V
Battery Quantity	2	2	3	4	8
Backup time (full load)	9 min	5 min	5 min	5 min	5 min
Recharge time	<4 hours to 90%				
Dimensions ins/mm W x D x H	5.6 x 17.2 x 8.3 140 x 436 x 210			6.7 x 17.8 x 8.9 170 x 450 x 226	
Weight lbs/kg (net)	31 / 14	33 / 15	56 / 25	66 / 30	20 / 44 *

* UPS Only. Battery pack 57 lbs / 26 kg

Standard Run-Time Compact Tower Models

Capacity	1000VA / 600 W	1250VA / 750 W	1500VA / 900 W	2000VA / 1200 W	3000VA / 1800 W
Input Connection	Detachable power cord				Hardwire terminals
Output Connection	8 x NEMA or IEC				6 x NEMA or IEC
Battery Type & Rating	Sealed, lead-acid 7.2Ah/12V	Sealed, lead-acid 9Ah/12V	Sealed, lead-acid 7.2Ah/12V	Sealed, lead-acid 7.2Ah/12V	Sealed, lead-acid 7.2Ah/12V
Battery Quantity	2	2	3	4	8
Backup time (full load)	5 min	4 min	5 min	5 min	5 min
Recharge time	<4 hours to 90%				
Dimensions ins/mm W x D x H	5.5 x 15 x 8.2 140 x 381 x 210				6.7 x 17.7 x 8.9 170 x 450 x 226
Weight lbs/kg (net)	15.9 (35.0)	16.1 (35.4)	16.3 (35.8)	16.4 (36.1)	19.5 (43.0)

Standard Run-Time 19" Rack-mount Models (3U)

Capacity	600VA / 360W	1000VA / 600W	1500VA / 900 W	2000VA / 1200 W
Input Connection	Removable IEC power cord or fixed power cord			
Output Connection	4 x NEMA 5-15R			
Battery Type & Rating	Sealed, lead-acid 7.2Ah/12V	Sealed, lead-acid 7.2Ah/12V	Sealed, lead-acid 7.2Ah/12V	Sealed, lead-acid 7.2 Ah/12V
Battery Quantity	2	2	3	4
Backup time (full load)	9 min	5 min	5 min	5 min
Recharge time	<8 hours to 90%			
Dimensions ins/mm W x D x H	19 x 15 x 5.2 485 x 381 x 130			
Weight lbs/kg (net)	38 / 17.3	44 / 20	55 / 25	61.6 / 28

14. Specifications (cont'd)

Standard Run-Time 19" Rack-mount Models (2U)

Capacity	600VA / 360 W	1000VA / 600 W	1500VA / 900W	2000VA / 1200 W
Input Connection	Removable IEC power cord or fixed power cord			
Output Connection	6 x NEMA 5-15R			
Battery Type & Rating	Sealed, lead-acid 7.2Ah/12V	Sealed, lead-acid 7.2Ah/12V	Sealed, lead-acid 7.2Ah/12V	Sealed, lead-acid 7.2 Ah/12V
Battery Quantity	2	2	3	4
Backup time (full load)	9 min	5 min	5 min	5 min
Recharge time	<8 hours to 90%			
Dimensions ins/mm W x D x H	19 x 16.9 x 3.3 485 x 430 x 84			19 x 24.2 x 3.3 485 x 615 x 84
Weight lbs/kg (net)	38 / 17.3	44 / 20	55 / 25	95 / 43.2

Extended Run-Time Tower Models

Capacity	1000VA / 600 W	1500VA / 900 W	2000VA / 1200 W	3000VA / 1800 W
Input Connection	Fixed power cord			Hardwire terminals
Output Connection	6 x NEMA 5-15R			H/W + 6 x NEMA 5-15R
Battery Type & Rating	Sealed, lead-acid 7.2Ah/12V	Sealed, lead-acid 17Ah/12V	Sealed, lead-acid 17Ah/12V	Sealed, lead-acid 17Ah/12V
Battery Quantity	4	3	4	4
Backup time (full load)	10 min	15 min	15 min	10 min
Recharge time	4 - 8 hours to 90% depending on variable charger setting			
Dimensions ins/mm W x D x H	6.7 x 17.7 x 8.8 170 x 450 x 224	6.7 x 18.9 x 16.9 170 x 480 x 430		6.7 x 21.6 x 16.9 170 x 550 x 430
Weight lbs/kg (net)	50 / 22.7	90 / 41	110 / 50	125 / 57

Extended Run-Time 19" Rack-mount Models

Capacity	1000VA / 600 W	1500VA / 900 W	2000VA / 1200 W	3000VA / 1800 W
Input Connection	Fixed power cord			Hardwire terminals
Output Connection	4 x NEMA 5-15R			H/W + 6 x NEMA 5-15R
Battery Type & Rating	Sealed, lead-acid 7.2Ah/12V	Sealed, lead-acid 8.5Ah/12V	Sealed, lead-acid 8.5Ah/12V	Sealed, lead-acid 12 Ah/12V
Battery Quantity	4	3	4	4
Backup time (full load)	10 min	8 min	8 min	7 min
Recharge time	4 - 8 hours to 90% depending on variable charger setting			
Dimensions ins/mm W x D x H	19 x 22 x 5.2 485 x 560 x 130			19 x 22 x 7 485 x 560 x 178
Weight lbs/kg (net)	52 / 24	61 / 28	69 / 32	113 / 51

15. Warranty

15.1 Limited Three-Year Warranty and Exclusions

NOTE: For this warranty to be valid, completed registration information must be received within 30 days of original purchase.

Marathon Power warrants to the original purchaser, who must have properly registered the product within 30 days of purchase, and not for the benefit of anyone else that this product at the time of its sale by Marathon Power is free of defects in materials and workmanship for three (3) years (batteries for 2 years within the USA, Canada and Mexico, otherwise 1 year) from the original purchase date. Marathon Power will correct such defects by repair or replacement, at its option, if within such three year period the product is returned prepaid and all warranty claim instructions are followed. This warranty excludes labor for removal or reinstallation of this product. This warranty is void if this product is installed improperly or in an improper environment, overloaded, misused, opened, abused, or altered in any manner, or is not used under normal operating conditions or not in accordance with all labels or instructions. There are no other or implied warranties of any kind, including merchantability and fitness for a particular purpose, but if any implied warranty is required by the applicable jurisdiction, the duration of any such implied warranty, including merchantability and fitness for a particular purpose, is limited to three years. Marathon Power is not liable for incidental, indirect, special or consequential damages, including damage to, or loss of use of, any equipment, lost sales or profits or delay or failure to perform this warranty obligation.

15.2 Limitations & Claims

This warranty does not cover any Marathon Power UPS or any properly connected electronic equipment which has been improperly installed, overloaded, abused or altered in any manner, or is not used under normal operating conditions, or in accordance with any labels or instructions, and does not cover any damage to properly connected electronic equipment resulting from a cause other than a "surge".

Damage caused by failure to provide a suitable installation environment for the product (including, but not limited to, lack of a good ground) will not be covered by this warranty. This warranty does not apply to damage caused by direct lightning strikes, or damage caused by electrical disturbances that exceed published product specifications. These products are intended to limit the maximum amplitude of transient voltage surges on power lines to specified values. They are not intended to function as surge arrestors. The UPS is intended to be installed on the load side of the service entrance and has been tested to verify that transient voltage surges are limited when subject to non-repetitive transient voltage surge events. This warranty excludes any incidental, indirect, special or consequential damages, including without limitation, labor for removal or reinstallation of the Marathon Power UPS or any connected electronic equipment, data loss or alteration loss of equipment use, lost sales or profits and any such damages for delay or failure to perform this warranty obligation. This warranty is in lieu of and excludes all implied warranties of merchantability or fitness for use. In addition, the warranty does not cover restoration of lost data and reinstallation of software. Some states may not allow the exclusion or limitation of incidental or consequential damages or other remedies, so the above exclusions or limitations may not apply to you.

Take the following steps to file a warranty claim: Contact us at Marathon Power, Inc., Attn: Returns, 2538 E. 54th Street, Huntington Park, California 90255 or call (310) 689-2328 within 30 days of the occurrence. Be prepared to provide detailed information about the event, any damage, the UPS model number, purchase date and location. You will then be provided with a Return Authorization Number (RAN), and be instructed to forward your proof of purchase (receipt), an explanation of the event and your UPS. If Marathon Power determines that the damage was due to a "surge", we may request that all connected equipment be submitted for evaluation. Marathon Power is not responsible for shipping costs. In the event that the equipment has been damaged by a "surge" Marathon Power will reimburse you for repair or replacement at fair market value (on a pro rata basis) as indicated by the respective amounts above. The warranty coverage is above and beyond, only to the extent needed, of that provided by any other source, including but not limited to any connected equipment coverage, any manufacturer's warranty or insurance policy. To receive payment for repair to damage due to a "surge," the original purchaser should (upon prior approval from Marathon Power) have such equipment repaired by an authorized service center of such equipment's manufacturer. The original purchaser will submit a repair bill along with a statement from the repair facility documenting the nature of the damage and how it was sustained to said equipment.

Notes



MARATHON
P O W E R

Marathon Power, Inc. 2014

2538 E. 54th Street
Huntington Park, CA 90255

Office: 310-689-2328

Fax: 310-689-2329

support@marathon-power.com

www.marathon-power.com