



# DIN Rail

Uninterruptible Power System

User Manual for Models:

SDRS-0300H1 • SDRS-0300H2  
SDRS-0500-H1 • SDRS-0500-H2

300W - 500W



## Table of Contents

Section	Page
Safety Instructions.....	4
Introduction.....	4
1. Presentation.....	5
2. Installation.....	6
3. Operation.....	7
4. Alarm.....	7
5. Software.....	8
6. Troubleshooting.....	9
7. Specifications.....	10
8. Warranty.....	11

## Important Safety Instructions

### IMPORTANT SAFETY INSTRUCTIONS SAVE THESE INSTRUCTIONS

This Manual Contains Important Instructions that should be followed during Installation and maintenance of the UPS and Batteries.

**WARNING:** Intended for installation in a controlled environment.

**CAUTION:** Do not dispose of batteries in a fire, as they may explode.

**CAUTION:** Do not open or damage the battery, electrolyte may be released which is harmful to the skin and eyes.

**CAUTION:** A battery can present a risk of electric shock and high short circuit current.

The following precautions should be taken when working with batteries:

- a. Remove watches, rings and other jewelry or metal objects.
- b. Use only tools with insulated handles.
- c. Wear rubber gloves and boots.
- d. Do not lay tools or metal parts on top of batteries.
- e. Disconnect charging source prior to connecting or disconnecting battery terminals.

**CAUTION:** Risk of Electric Shock – UPS equipment outputs remain live with main disconnect in off position.

Battery replacement should be performed or supervised by personnel with knowledge of batteries. Keep unauthorized personnel away from the batteries.

When replacing batteries, replace with the same type and number of batteries:

Do not connect any additional batteries.

## Introduction

### Please read and save this manual!

The information provided in this manual refers to our single phase, DIN-Rail UPS. It covers basic functions, operating and installation instructions, and cautionary notes. Installation must be carried out in accordance with this manual as well as local electrical regulations and should only be performed by qualified personnel to avoid the risk of electric shock or damage to the unit. Any warranties covering these units will become void if the unit is found to have been incorrectly connected or tampered with.

# 1. Presentation

## Front Panel



### 1. ON/OFF/TEST/SILENCE Button:

- Press the button and hold for more than one second to turn the UPS ON.
- Press the button for less than one second to activate the self-testing (AC MODE),
- Press the button for less than one second to silence the UPS audible alarm (BATTERY MODE),
- Press for more than four seconds to turn OFF.

### 2. BATTERY FAULT / OVERLOAD Indicator (Red LED):

- The LED will flash when the battery needs to be recharged and tested.
- The LED will illuminate when the unit is subjected to an overload condition.
- If the unit shuts down due to overload, the LED and alarm will continue for two minutes.

**3. BATTERY MODE Indicator (Yellow LED):** The LED will illuminate when the UPS is supplying battery power to the loads.

**4. AC MODE Indicator (Green LED):** The LED will illuminate when the line input voltage is normal.

**5. Remote ON/OFF:** The remote switch provides the same functions as the front panel switch including ON/OFF /TEST/SILENCE functions.

**6. IP20-rated INPUT Screw Terminals (see table below)**

**7. IP20-rated OUTPUT Screw Terminals (see table below)**

Screw Type	M3.0; Current rating = 30A, AC 300V
Insulation Withstands Volts	AC 2000V min.
Wire Stripping length	8mm
Wire Range	10-24AWG
Screw Torque	9 lb.-in

**8. BREAKER:** Protection from AC overload and short circuit.

## Bottom Panel

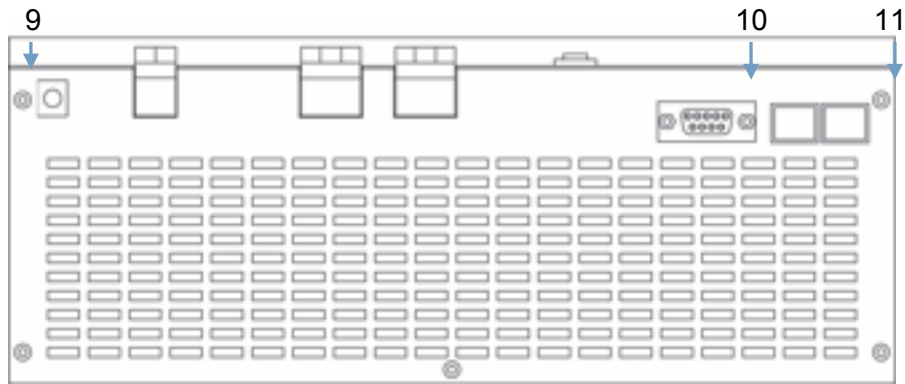

**9. AUX DC OUTPUT:** Output terminal provides DC power source to the relay card (Optional Dry contact relay box).

**10. Surge Protection:** Data line surge protection for phones (UL497A).

**11. Auxiliary power:** Backup power source.

## 2. Installation

**2.1 Inspection:** Upon receiving the UPS, inspect it. The packaging is recyclable. Save it for reuse or dispose properly.

**2.2 Placement:** To prevent the risk of fire or electronic shock, install the UPS in a temperature and humidity controlled ventilated enclosure, free of conductive contaminants, moisture, flammable, gases, and corrosive substances.

To reduce the risk of electronic shock, do not remove cover, it has no user-serviceable parts  
Hazardous live parts inside this unit are energized from the battery supply even when the input AC power is disconnected

**2.3 Utility power:** The terminal block is used to “hardwire” the UPS, thus allowing connection of input/output wiring. Use AWG wire as stated in the table. Input / Output wires should be secured with terminal block screws using 9 lb.-in. of torque. The input utility power should match with the UPS. (For example, the voltage rating of UPS is 120V/(220V), input utility should also be 120/(220)).

### 2.4 Connection:

- Connect the AC Input power conductors (L, N, and G) to the UPS Input Terminal Blocks (L, N, and G) respectively.
- Connect the Output Power Conductors (L, N, and G) from the UPS Output Terminal Blocks to the load equipment (L, N, and G) respectively.
- The UPS Input and Output Terminal Blocks can accept conductor sizes ranging from 10AWG to 18AWG.

## 2.5 DIN Rail UPS Mounting Instructions

The recommended ventilation is 2" (50mm) top and bottom.

Step 1:

Tilt the UPS unit as illustrated below, with the upper edge of UPS leaning forward.

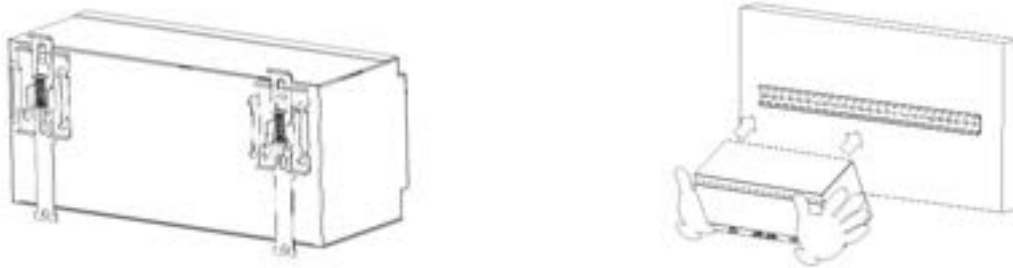

Step 2:

Place the upper hooks of DIN Rail Brackets onto the upper edge of DIN Rail, push and hold down the spring-loaded bars on the DIN Rail Brackets, then push the bottom of UPS forward against the DIN Rail, and finally release the spring-loaded bars.

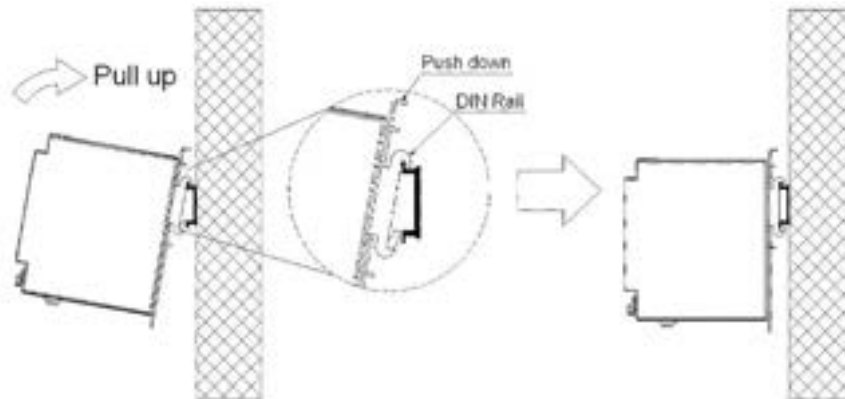

Step 3:

Slightly pull the bottom of the UPS outward to ensure that the spring loaded hooks are securely engaged onto the lower edge of the DIN Rail.

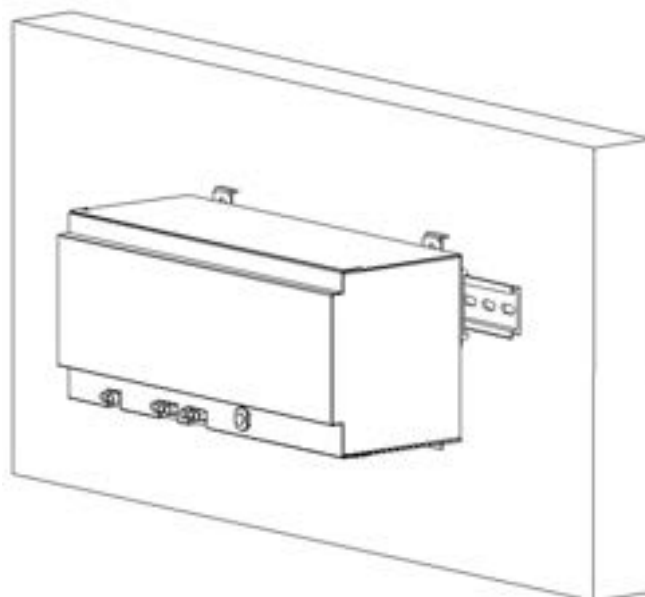

## 3. Operation

This chapter contains information necessary for the operation of the UPS unit.

### 3.1 General Description

As an Off-Line UPS, it provides reliable protection to your daily equipment while automatically charging the battery.

- Main power is transferred to the equipment with surge protection
- During a power failure, the UPS immediately provides backup power from the battery.

#### Line-Mode/Battery-Mode

UPS will operate in Line-Mode that supports power and charges the battery while connected to AC power. During a power outage, the UPS will switch to Battery-Mode, and power is maintained from the battery. In case power outage time exceeds the duration of the Battery-Mode, UPS will shut down until power is restored in order to prevent the discharge of the battery.

#### Diagnostic Test

An advanced battery management system monitors the conditions of the batteries. It will send early warnings if a battery replacement is needed. Diagnostic tests can be performed from the control panel.

## 4. Alarm

**4.1 “BACKUP” (slow alarm):** When the UPS is working in the “BACKUP” mode, there would be an audible alarm. When the UPS returns to “LINE” mode operation, the alarm would stop.

Attention: In the “BACKUP” mode, the alarm will beep every 2 seconds. (Slow-speed beep). Attention: The UPS provides mute function for this warning. When the beeping sound occurs, press "ON" to stop it; and press "ON" again to resume the sound.

**4.2 “LOW BATTERY”(rapid alarm):** When the UPS is working in the “BACKUP” mode, with energy of the battery between 20%~30% (low level), the UPS will beep rapidly until the UPS shuts down from battery exhaustion or returns to “LINE” mode operation.

Attention: The alarm due to low voltage of the batteries beeps every 0.5 second. Attention: The rapid alarm under “LOW BATTERY” condition cannot be muted.

**4.3 “OVER LOAD” (continuous alarm):** When the UPS is working under overload condition (the connected loads exceed the maximum rated capacity), the UPS will emit continuous alarm to warn an overload condition. In order to protect the unit and the loads, the UPS will be automatically turn Off. Please disconnect nonessential devices from UPS to eliminate the overload alarm.



## 5. Software (Optional)

### 5.1 Power Monitoring Software

The UPS-MON software (or other power monitoring software) is applied via standard RS-232 interface to perform monitoring functions. The cable must be connected from the UPS end to a REMOTE PORT on the computer end. It can be either be COM 1 or COM 2. It provides an orderly shutdown of a computer in the event of a power failure. Moreover, UPS-MON displays all the diagnostic symptoms on the monitor, such as Voltage, Frequency, Battery level and so on. The software is available for Windows XP, 7,8, 10, Server-2000, 2003, 2008, 2012 and Linux. Call Marathon Power technical support for assistance on OS.

### 5.2 Interface Kits

A series of interface kits are available for operation systems (Such as PLC, SCADA, signal controllers, etc.) that provide UPS monitoring. Each interface kit includes a special interface cable required to convert status signals from the UPS into signals which the individual system recognizes. The interface cable from the UPS end must be connected to a REMOTE PORT on the computer end. It can be either be COM 1 or COM 2. For other installation instructions and powerful features please refer to READ.ME file.

**Attention:** Use only the cable supplied by factory or authorized UPS monitoring cable!

### 5.3 The characteristics of computer interface port

The computer interface port has the following characteristics:

- The communication port located on the bottom of the UPS may be connected to a host computer. This port allows the computer to monitor the status of the UPS and control its operations in some cases. Its major functions normally include some or all of the following:
  - a. To broadcast a warning when power fails.
  - b. To close any open file before the battery is depleted.
  - c. To turn-off the UPS.
- Some computers are equipped with a special connector to link with the communication port. In addition, a special plug-in cord may be needed. Some computers may need special UPS monitoring software. Contact Marathon Power for details on the various interface Kits.

## 6. System Configuration

### System Configuration

The UPS device and battery make up the system. Depending on the load requirements, certain additional options are available. Please consider the following criteria before selecting a UPS system:

- The output power rating (VA) depends on the power requirement of the load equipment. When measuring the power requirement, please allow a margin for future expansion, tolerance and calculation error.
- The size of the battery is dependent on the duration in Battery-mode.

### 6.1 UPS Control

#### Control Panel Functions

Display	Function Description	Display	Function Description
Battery fault Overload	<u>Overload/ Battery Fault(Red)</u> Battery fault: Rapid flash Overload: steady light	AC mode	<u>AC mode(Green)</u> UPS is operating with Main power
Battery Mode	<u>Battery mode(Yellow)</u> UPS is operating with Battery power		
<b>Button Display</b>			
On/Off/Test /silence	<u>ON/OFF/TEST/Silence Button</u> The master button for UPS control, refer to Button Operation		

#### Button Operation

##### Cold Start function

When the main power is disconnected from UPS, it is capable of starting with battery power. Simply start the UPS as per the instruction below.

##### “On/Off/Test/Silence” button

##### Turn on the UPS

Press the "ON" button until a single "beep" alarm disappeared or the LED display turns on.

- Press the "OFF" button for 3 seconds during Line/Battery-mode.
- To avoid electrical hazards, please turn off the internal/external battery breaker and wait until all fans completely shut down.

**Test:** Press once to start self-test function during Line-Mode

**Silence:** Press once to enable/disable alarm buzzer during Battery-Mode **Note:**

Remote ON/OFF: Connect the external control, its function is same as the “On/off/Test/Silence” button.

#### Green Mode

The Green mode feature will enable UPS no-Load or light-load shutdown to maintain power consumption and battery life. During battery mode, the UPS will shut down approximately 4 min with no load/light load operating. Green mode can also be enabled or disabled via monitoring software.

## 7. UPS Configuration

### UPS Manual Test

Manual tests for UPS or battery can be conducted from the UPS configuration and functional even when the UPS is not charging the battery.

Simple Test: It's recommended to conduct a simple simulation test when:

1. The first use of UPS.
2. Adding new loads.
3. 6 months' regular check-up

Switch on the UPS and wait for the power indicator to light up, then unplug UPS to simulate the main power failure.

Manual Battery Test: Press the "test" button once. UPS will automatically conduct a self-test. Please note that the UPS will briefly switch to battery mode.

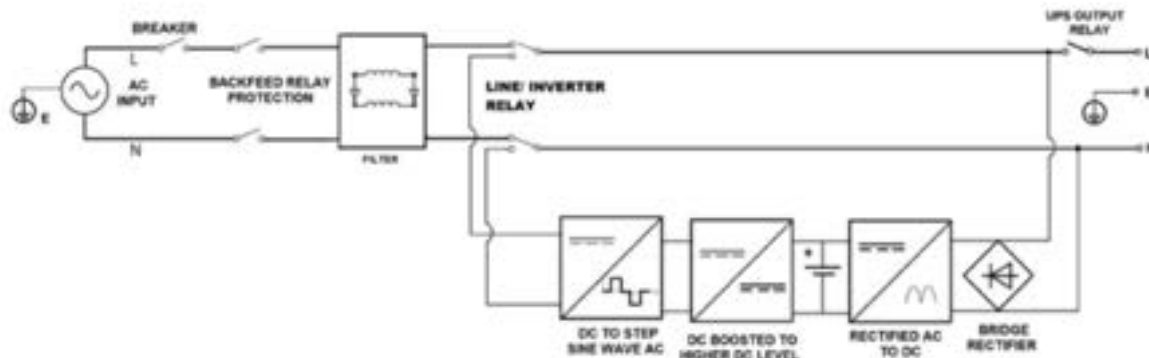

## 8. Maintenance

As long as all the installation, environmental and operational requirements have been followed and met, the UPS will require little or no maintenance for many years. The batteries are the only component that should eventually need replacing. Their useful life depends primarily on the following two factors; the ambient temperature of the environment in which the UPS is located and the number of times they're called into use (i.e. discharged). In both cases, the lower the number, the longer they will last. At an ambient temperature of 77°F (25°C), typical battery lifetime is 2 years. A test of the UPS and batteries should be carried out at regular intervals (every 6 months) to verify that back-up time is still adequate for the application. The UPS should also be charged every six months if it is kept in storage and not used.

### Maintenance and Precautions

#### 8.1 Harsh Environments:

Marathon Power Standard UPS's are generally designed for clean environments, free of dust, salt, and other environmental contaminants. Some of the harmful effects of environmental contamination are as follows:

- Dust, chemicals and airborne pollutants can clog and corrode the inside of a UPS and lead to failures.

- Installing a UPS in a harsh environment leads to overheating, and damage to internal boards, components, etc. It can also create arc flashes which can be very dangerous to anyone in close proximity to the UPS. Arc flashes are a shock hazard to anyone nearby and could potentially cause serious injury or death.
- Salt from humid, ocean air can also corrode the internal components of a UPS as well as the batteries. This can cause premature failure of parts/components and lead to electrical short circuits.

Please read the following safety instructions.

### **8.2 Transportation**

Please handle UPS with extreme caution since a high amount of energy is within the batteries. Keep the unit in position as marked on the packaging and never drop the unit.

### **8.3 Storage**

Please read the following instructions if the UPS is not installed immediately:

- Store the equipment in its original packing and shipping carton.
- Do not store in temperatures outside the range of +15°C to +25°C.
- Protect the equipment from wet or damp areas and moist air.
- To maintain the vitality of the batteries, please recharges the UPS at least 8 hours every six months.

### **8.3 Operation**

CAUTION: Ensure that all environmental concerns and requirements are met according to safety instruction.

- Please ensure that there are no flammable substances such as gases or fumes.
- Avoid extreme temperature and humidity. Protect the equipment from moisture.
- Ensure that the front of the UPS remains clear for user operation.
- Only authorized agents or technicians may service the unit.
- Do not touch live parts, components may contain hazardous or fatal voltage.
- Output receptacles may carry live voltage without connecting to the main power.
- Pay special attention to UPS air inlet; do not let it covered by dust.

### **DIN Rail UPS Battery Removal Instructions:**

1. Remove the screws from the ventilated panel to access the battery, and remove the panel.
2. Carefully disconnect the red and black wires from the battery terminals.
3. Remove the screws from the metal bracket on top of the battery, and remove the bracket.
4. Use the pull tab on the battery to carefully remove the battery from the UPS.
5. Replace the old battery with a new battery, and reverse the previous steps to reassemble the UPS.

For video instructions, follow this link: <https://youtu.be/07AxWqwgldo>

## 9. Appendix A - Troubleshooting

PROBLEM	CAUSE	CORRECTIVE ACTION
<b>If UPS does not turn ON</b>	ON/OFF/TEST/SILENCE button not pushed or push-time too short	Press the ON/OFF/TEST/SILENCE button more than 1 second
	(OR)	
<b>LED does not illuminate</b>	Battery voltage less than 10V	Recharge the UPS for at least 6 hours
	PCB failure	Replace the PCB, call for service
	Load less than 40W in battery mode	Normal condition, "No load shutdown function" is active
<b>UPS always in battery mode</b>	Loose AC input connection	Recheck input connection
	Blown input AC fuse	Replace the AC fuse
	Line voltage too high, too low or AC power failure	Normal condition
	PCB failure	Replace PCB, call for service
<b>Back up time too short</b>	Battery not fully charged	Recharge the UPS at least 6 hours
	PCB failure	Replace PCB, call for service
<b>Buzzer beeps continuously</b>	Output Overload	Remove some loads

## 10. Appendix B - Specifications

Model	SDRS-0300-H1 / H2					SDRS-500-H1 / H2				
Capacity	500VA / 300W					850VA / 500W				
<b>INPUT</b>										
Voltage	120V (+10%, -20%); 230V (±20%); 240V(+15% -20%)									
Frequency	50Hz ± 10%; 60Hz ± 10%									
Maximum Input Current	10A									
Inrush Current	25A									
Transient Suppression	EN61000-4-5, L-N: 1KV, L-G or N-G: 2KV									
Short Circuit Protection	Yes									
Battery String Voltage	12VDC									
<b>OUTPUT</b>										
Power Rating	500VA / 300W • 850W / 500W									
Output Voltage	120V / 208V / 230V / 240V ± 5%									
Frequency (On Battery)	50 / 60HZ ±0.3Hz									
Output Power Factor	0.6									
Waveform	Stepped Square Wave									
Load Crest Factor	3:1									
Transfer time	4-6 ms typical									
Overload Capacity	UPS automatic power off if overload exceeds 105% of nominal at 20 seconds; 120% at 10 seconds;130% at 3 seconds									
Short circuit protection	UPS output cut off immediately									
<b>BATTERY</b>										
Type	Sealed, maintenance-free lead acid battery									
Battery quantity	12V 7.2Ah x 1					12V 9Ah x 1				
Typical recharge time	8 hours to 90% capacity after full discharge									
<b>BACKUP TIME 500VA / 300W</b>										
% of Max Load (Watts)	10	20	30	40	50	60	70	80	90	100
Minutes	110	48	24	15	14	10	7	6	4	4
<b>BACKUP TIME 850VA / 500W</b>										
% of Max Load (Watts)	10	20	30	40	50	60	70	80	90	100
Minutes	73	32	17	13	8	6	5	3	2	2
<b>GENERAL</b>										
Dimension (W x D x H)	11.1 x 4.6 x 4.9 inches • 281mm x 116mm x 124mm									
Product weight	9.7 / 4.4kg					10.8 / 4.9kg				
Mounting	DIN Rail or Panel Mount									
Input Connection	Hardwire Terminal Block									
Output Connection to Loads	Hardwire Terminal Block									
Cooling	Natural Convection									
Shock and vibration	ISTA 2A									
Audible noise	< 40dBA (1meter from surface)									
Altitude, ft (m)	5000ft / 1524m without derating									
Operating temperature	32°F to 122°F / 0°C to 50°C (+/- 2°C )									
Storage temperature	5°F to 140°F / -15°C to +60°C									
Humidity	<95%, non-condensing									
Cooling	Natural Convection									
Approvals	<b>120V:</b> UL1778, UL508, cUR (UL File #E316102) CID2 Hazardous Locations, Explosion-Proof (UL File #E539035), CSA C22.2 NO. 107.3-14, 3rd Ed <b>230V:</b> CE									

**CAUTION:** Risk of Electric Shock – UPS equipment outputs remain live with main disconnect in off position.

## 11. Warranty

### Limited Three-Year Warranty and Exclusions

Marathon Power warrants to the original purchaser, and not for the benefit of anyone else that this product at the time of its sale by Marathon Power is free of defects in materials and workmanship for three (3) years (batteries for 2 years within the USA, Canada and Mexico, otherwise 1 year) from the original purchase date. Marathon Power will correct such defects by repair or replacement, at its option, if within such three-year period the product is returned prepaid and all warranty claim instructions are followed. This warranty excludes labor for removal or reinstallation of this product. This warranty is void if this product is installed improperly or in an improper environment, overloaded, misused, opened, abused, or altered in any manner, or is not used under normal operating conditions or not in accordance with all labels or instructions. There are no other or implied warranties of any kind, including merchantability and fitness for a particular purpose, but if any implied warranty is required by the applicable jurisdiction, the duration of any such implied warranty, including merchantability and fitness for a particular purpose, is limited to three years. Marathon Power is not liable for incidental, indirect, special or consequential damages, including damage to, or loss of use of, any equipment, lost sales or profits or delay or failure to perform this warranty obligation.

### Limitations & Claims

This warranty does not cover any Marathon Power UPS or any properly connected electronic equipment which has been improperly installed, overloaded, abused or altered in any manner, or is not used under normal operating conditions, or in accordance with any labels or instructions, and does not cover any damage to properly connected electronic equipment resulting from a cause other than a "surge".

Damage caused by failure to provide a suitable installation environment for the product (including, but not limited to, lack of a good ground) will not be covered by this warranty. This warranty does not apply to damage caused by direct lightning strikes, or damage caused by electrical disturbances that exceed published product specifications. These products are intended to limit the maximum amplitude of transient voltage surges on power lines to specified values. They are not intended to function as surge arrestors. The UPS is intended to be installed on the load side of the service entrance and has been tested to verify that transient voltage surges are limited when subject to non-repetitive transient voltage surge events. This warranty excludes any incidental, indirect, special or consequential damages, including without limitation, labor for removal or reinstallation of the Marathon Power UPS or any connected electronic equipment, data loss or alteration loss of equipment use, lost sales or profits and any such damages for delay or failure to perform this warranty obligation. This warranty is in lieu of and excludes all implied warranties of merchantability or fitness for use. In addition, the warranty does not cover restoration of lost data and reinstallation of software. Some states may not allow the exclusion or limitation of incidental or consequential damages or other remedies, so the above exclusions or limitations may not apply to you.

Take the following steps to file a warranty claim: Contact us at Marathon Power, Inc., Attn: Returns, 2538 E. 54th Street, Huntington Park, California 90255 or call (310) 689-2328 within 30 days of the occurrence. Be prepared to provide detailed information about the event, any damage, the UPS model number, purchase date and location. You will then be provided with a Return Authorization Number (RAN), and be instructed to forward your proof of purchase (receipt), an explanation of the event and your UPS. If Marathon Power determines that the damage was due to a "surge", we may request that all connected equipment be submitted for evaluation. Marathon Power is not responsible for shipping costs. In the event that the equipment has been damaged by a "surge" Marathon Power will reimburse you for repair or replacement at fair market value (on a pro rata basis) as indicated by the respective amounts above. The warranty coverage is above and beyond, only to the extent needed, of that provided by any other source, including but not limited to any connected equipment coverage, any manufacturer's warranty or insurance policy. To receive payment for repair to damage due to a "surge," the original purchaser should (upon prior approval from Marathon Power) have such equipment repaired by an authorized service center of such equipment's manufacturer. The original purchaser will submit a repair bill along with a statement from the repair facility documenting the nature of the damage and how it was sustained to said equipment.



Marathon Power, Inc. 2024  
2538 E. 54th Street  
Huntington Park, CA 90255  
Office: 310-689-2328  
Fax: 310-689-2329  
[support@marathon-power.com](mailto:support@marathon-power.com)  
[www.marathon-power.com](http://www.marathon-power.com)